



renewing human potential renewing human potential renewing human potential renewing

Center for International Rehabilitation

C I R

Products Engineering

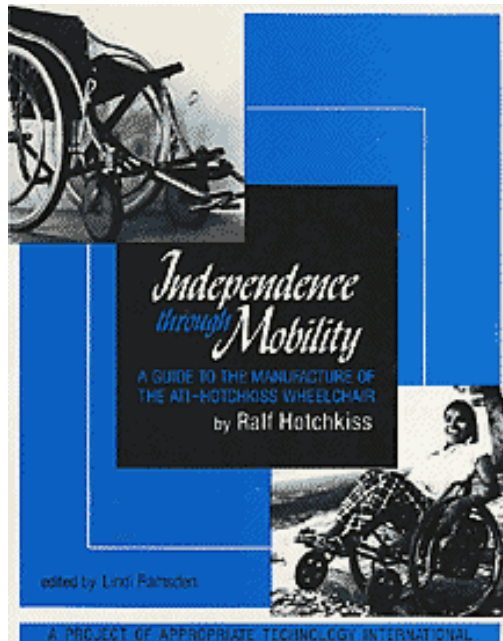

# Independence through Mobility

## A GUIDE THROUGH THE MANUFACTURE OF THE ATI-HOTCHKISS WHEELCHAIR

by  
Ralph Hotchkiss

edited by  
Lindi Ramsden

A PROJECT OF APPROPRIATE TECHNOLOGY  
INTERNATIONAL

Disabled people in the Third World are fighting to become actively involved in their communities, more mobile, and economically independent. To accomplish this, they need wheelchairs that are strong enough to withstand the stresses of

maneuvering over rugged terrain, yet light and compact enough to be agile and easily portable. These wheelchairs must be affordable and designed to be repaired locally.

With four years' support from Appropriate Technology International and the assistance of wheelchair builders in over 20 countries, Ralf Hotchkiss has designed a sturdy wheelchair that is ten pounds lighter than similarly featured commercial models. It can be manufactured locally by small groups of skilled mechanics in areas with access to thinwall steel tubing and simple welding equipment. It costs approximately \$80 (U.S.) for materials plus the cost, with overhead, of less than a week's work by a skilled mechanic.

This book contains detailed instructions for making the ATI-Hotchkiss Torbellino wheelchair, plus detailed information on the establishment and operation of the successful small businesses which have manufactured and sold the Torbellino wheelchair.

## [Table of Contents](#)

### Credits:

- Cover was done by Graphic Artist Lily Kaplan
- Caricatures were drawn by Cartoonist David Bilbrey
- Computer Programming was done by Mieke de Neef
- Mechanical drawings were done by Ramsden using pen and ink and by Hotchkiss using AUTOCAD Computer Aided Design
  - Software on an IBM PC with a Houston Instruments Plotter
    - Photos by Hotchkiss and Marc Krizack
- The galleys were produced on an IBM PC Computer using Magic Print Software; a Diablo 620 Printer was used with Boldface PS type.
- Printing Software was provided by Amy Kelly and Henry Dakin, Washington Research Institute, San Francisco
- This book was printed by GRT Book Printing, Oakland, California

### Published by:

Appropriate Technology International  
1331 H St., N.W.  
Washington, D.C. 20005  
U.S.A.

ATI implements its mission with public funds made available by the United States Congress through the Agency for International Development. ATI's program is carried out in cooperation with the Employment and Enterprise Development Division of the Office of Rural and Institutional Development within the Bureau of Science and Technology of the Agency for International Development.

Upon request, Appropriate Technology International may grant permission to copy or otherwise reproduce this manual or any portions thereof. A copy of any publication in which a portion of the text or illustrations is included must be sent to Appropriate Technology International at the above address.

Copyright 1985 by Appropriate Technology International

# Center for International Rehabilitation

## Foreword

"The system of mass production...presupposes that you are already rich, for a great deal of capital investment is needed to establish one single workplace. The system of **production by the masses** mobilizes the priceless resources which are possessed by all human beings, their clever brains and skillful hands, and **supports them with first class tools**", and the training/instruction to fully utilize these resources.

E.F. Schumacher, *Small Is Beautiful*, 1973

"Technologies that are small, simple and capital saving are more appropriate to the needs and resources of poor countries than are the large-scale labor saving technologies developed in the West during their heyday of cheap energy... The only sane alternative lies in the direction of technologies that are relatively small, simple, capital saving and non-violent, and economics as if people mattered."

George McRobie, *Small Is Possible*, 1981

These two quotations from the founders of the appropriate technology field reflect both ATI's philosophy and the *raison d'être* behind this production manual. People do matter to ATI and to Ralf Hotchkiss. We share the belief that utilization of appropriate technology (technology adapted to the local resource endowment) can increase income and improve the quality of the lives of the users of these technologies and consequently awaken these people to their own potential for further development.

We have made this production manual available so that small entrepreneurs and shops run by and for the disabled can construct the ATI-Hotchkiss Wheelchair with a minimal capital investment. This wheelchair, designed under an ATI grant and subsequently field-tested throughout Latin America, is lightweight, durable, extremely well-balanced; it can be fit to the individual, and can be manufactured locally at one third the price of many imported chairs.

This production manual should play an important role in increasing the availability and thus lowering the price of high quality wheelchairs in the Third World. People seeking to buy wheelchairs in many small countries have found themselves to be captives of a single importer. As Adam Smith put it in *Wealth of Nations* in 1776, "monopolists, by keeping the market constantly under-stocked, by never fully supplying the effectual demand, sell their commodities much above the natural price." The resulting price "is the highest which can be squeezed out of the buyer." By increasing competition in the wheelchair market, we hope to urge the prices of quality wheelchairs down toward their natural level.

As the prices drop, more and more disabled people will be able to obtain state-of-the-art wheelchairs. This could be the first step in permitting them to exercise their options and to begin working toward the fulfillment of their dreams.

Ton de Wilde, Executive Director

[Table of Contents](#)

# Center for International Rehabilitation

## Introduction



Disabled people throughout the world, together with their families and friends, are beginning to change the ways that they live, work, and participate in their communities. Refusing to be defined by the attitude that they are a burden on society and no longer willing to remain hidden from others, disabled people are fighting to become actively integrated into schools, regular jobs, places to live, and public life. They know from experience that they can do many things well; they know that being successful does not have to be the exception for disabled people. They intend to live with independence and dignity, and are rapidly overcoming the obstacles that stand in their way.

Just as a blacksmith needs high quality tools to do a specific job, disabled people need the highest quality equipment to assist them in actively pursuing their goals. People whose mobility needs are not met by crutches or canes need wheelchairs that will enable them to be as mobile, productive, and independent as possible.

In the industrial world, the increasing demand from disabled people for mobility and independence has resulted in a revolution in wheelchair design. Lighter and faster chairs made of space-age materials are being introduced every year. These new wheelchair designs are allowing U.S. wheelchair riders to compete in events such as the Boston Marathon (where the wheelchair racers make better time than the runners), to get to classes and jobs on time, and to move more easily, thus saving their energy for other tasks.

Unfortunately, the high cost of lightweight wheelchairs has put them out of reach of most of the Third World's disabled people. Those who can afford the high price of imported chairs often find that the chairs are not built to withstand the stresses of dirt roads, farm fields, curb climbing, and pocked pavement. When mechanical failures occur, it is often impossible to obtain replacement parts.

Poorer disabled people have either gone without a wheelchair or have used locally manufactured models that are often heavy, confining, and lacking in many of the necessary features of state of the art chairs.

Third World wheelchair riders need wheelchairs that can fold to fit in crowded living quarters or in the aisle of a bus. Many need wheelchairs with folding footrests that allow the rider to pull in close to beds and tables, and armrests that do not impede lateral transfer. These wheelchairs should have good traction, stability, and should be light and agile enough for the rider to travel over rough ground. Wheelchairs built for riders in the Third World should be strong enough to withstand rough handling (as they are tossed on and off the roof of a bus). When parts do fail, they must have been designed to be repaired locally. Last but not least, these wheelchairs must be affordable. Fancy wheelchairs are of no use if no one can afford to purchase them.

Working over the past four years with the support of Appropriate Technology International, and with the assistance of wheelchair builders in over 20 countries, we have designed the ATI-Hotchkiss wheelchair, the Torbellino (the chair was first named Torbellino, or whirlwind, in Peru). This wheelchair is ten pounds lighter than commercial wheelchairs with similar features, yet it is strong enough to stand up to heavy use. It can be manufactured locally and could be sold in many countries for less than one third of the cost of a comparable import.

Most wheelchairs are designed to be mass produced using highly expensive press forming equipment. Since capital and materials are severely limited in many Third World countries while resourceful labor is abundant, conventional manufacturing techniques are inappropriate. The Torbellino wheelchair has been designed to be built by small groups of mechanics using inexpensive handtools in areas where workers have access to thin wall steel tubing and gas welding. A high level of skill is required to build these chairs successfully; a high level of investment is not.

E. F. Schumacher in his book *Small Is Beautiful* said: "Any third-rate engineer or researcher can increase complexity; but it takes a certain flair of real insight to make things simple again." Our wheelchair design is a collection of such insights gained worldwide from some of the best wheelchair builders, many of whom are also wheelchair users. We have tapped into a rapidly growing network of small-scale wheelchair makers who are developing, producing, and selling full featured wheelchairs at highly competitive prices.

This manual has been written to make this technology generally available. It includes step by step descriptions of how to build the ATI-Hotchkiss wheelchair, guidelines for starting a small manufacturing business, detailed lists of the tools, parts, and other equipment you will need to begin production, as well as many photographs and diagrams which we hope will communicate when words fail us.



## OUR CURRENT DESIGN:

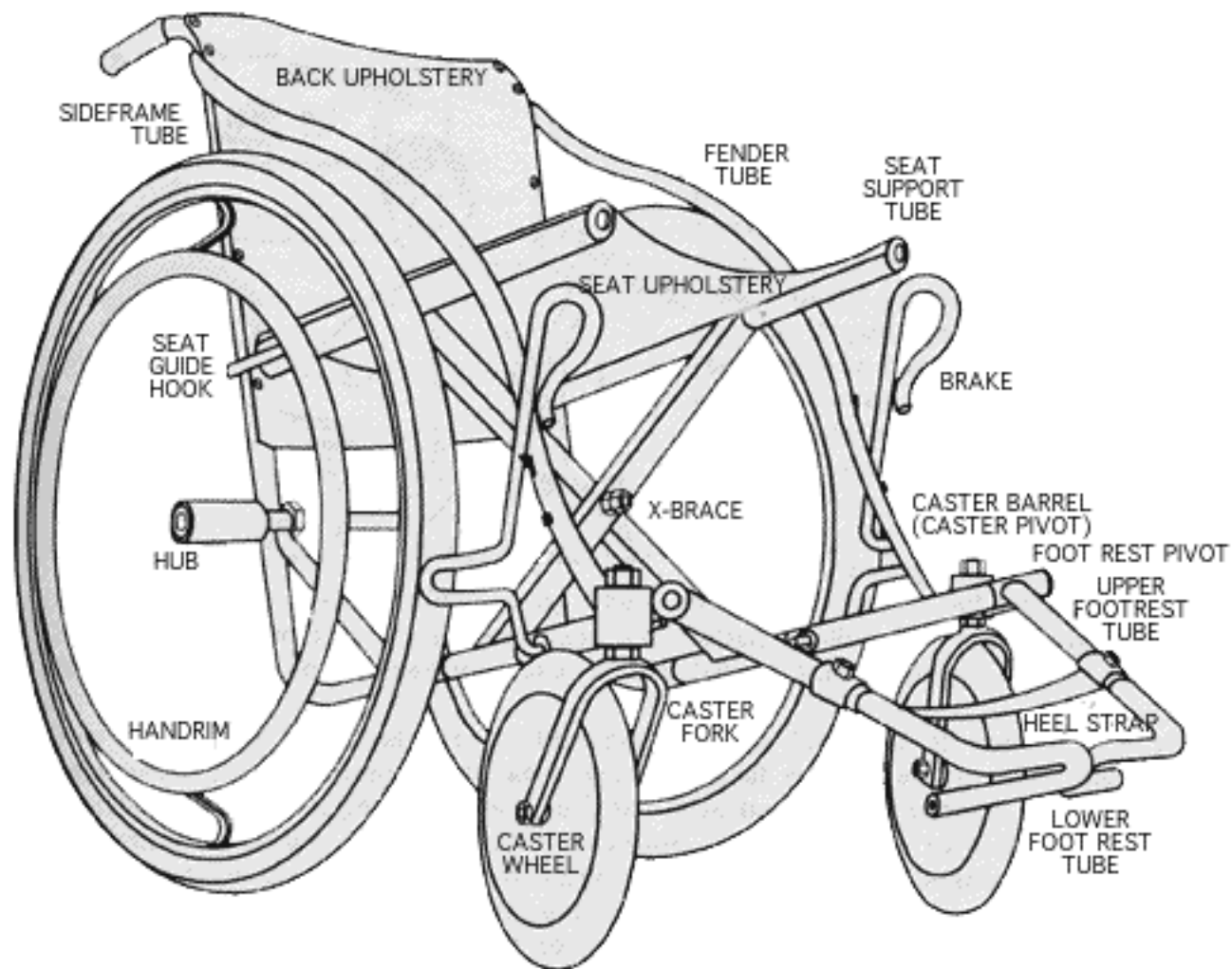

Even as this book goes to press, new ideas are being developed to improve the design of the chair and the methods for production. This diagram is our most recent design. We hope that you will use the ideas in this manual, improve upon them, and send us drawings and explanations of your good ideas. In this way you can join in the efforts of many others throughout the world who, by successfully manufacturing low cost wheelchairs, are enabling members of their communities to live more independent, productive, and dignified lives.

[Table of Contents](#)

# Center for International Rehabilitation

## Chapter 1 Starting a Small Business

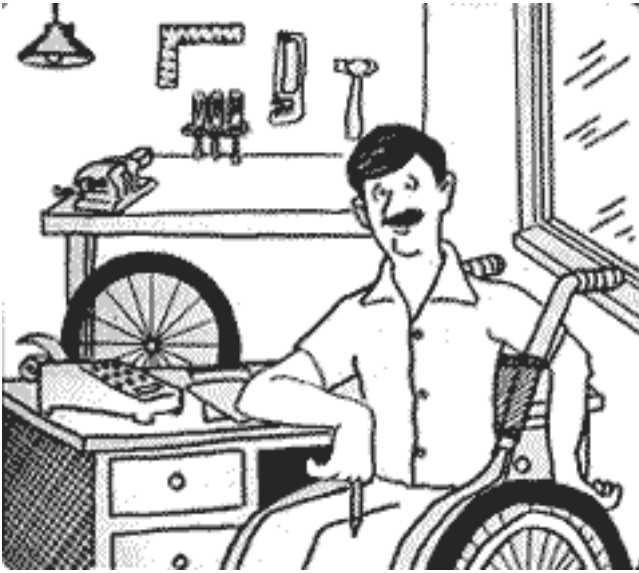

Learning how to make a well-crafted wheelchair is just one part of starting a wheelchair manufacturing business. It is equally important to learn the skills necessary to start and manage a successful small business. Your business is less likely to go bankrupt in a few months if you plan carefully, project your start-up costs accurately, and raise enough money to last until your shop can produce and sell enough chairs to begin to make a profit. It takes careful planning to accurately project start-up costs. We have seen a wide range of estimates, from groups whose start-up

costs exceeded their estimates by 300% to the Asociacion Del Rehabilitacion Del Impedido De Asuncion, a well organized association of disabled people in Asuncion, Paraguay, whose cost projection came within 20% of actual costs.

Your business is less likely to go bankrupt in the long run if you have a person experienced in accounting to keep your financial records and provide you with the financial information you will need to make wise business decisions. For example, to determine a selling price for the wheelchair, it is important to include not only the direct costs involved (materials to make the chair and a mechanic's labor); you must also calculate the overhead or indirect costs that are incurred (rent, payment on your loan, truck rental, depreciation of tools and equipment, office expenses, taxes, etc.). Without the help of an accountant it is not always obvious whether your business is making money, breaking even, or losing money until it is too late.

This chapter includes information that should help you to answer the following questions:

- What sorts of skilled workers will we need to operate a successful shop?
- How can we estimate how much money it will take to start our shop?
- How much does it cost to produce each chair?
- Are there enough customers in the area who will be able to pay for a wheelchair?

## NECESSARY WORKERS

Even the best mechanic in the world cannot run a successful wheelchair manufacturing business without some skill in accounting. Without a qualified accountant, you may be

surprised to find that your business has not been going as well as you thought. One small business kept trying to increase the volume of sales to pull themselves out of a bad financial situation. They did not have an accountant nor adequate financial records; consequently, they didn't know that they were selling their product below cost. They successfully increased their sales, but this only increased their debt. Eventually, they went out of business.

The first successful start-up that we were able to observe, the factory in Asuncion, Paraguay, obtained the services of an accountant who set up their bookkeeping system before they began to manufacture wheelchairs. Their accountant continues to work one half day a week, keeping the books up to date. We highly recommend that you hire someone experienced in accounting to be directly responsible for the accounting on an ongoing basis. He or she can provide the information you will need to make sound business decisions.

The business will also need a master mechanic who has worked with sheet metal and who is a competent welder. A mechanic who has also had experience working with light metal tubing would be ideal. Experienced autobody workers or bicycle makers and repair persons will have skills that are transferable to making wheelchairs. In addition, it is important that the mechanic be comfortable with the mathematics involved in measuring angles and lengths.

The best way for someone to learn how to build our wheelchairs is to visit an established wheelchair shop. Currently, there are wheelchair businesses building the ATI-Hotchkiss Torbellino type of chair in Nicaragua, Mexico, Peru, Paraguay, the Philippines, Colombia and the U.S.

The cost analyses presented in this chapter have been based on a business that employs three mechanics, one master mechanic, one administrator, and an accountant who works 1/2 day per week.

## HOW MUCH MONEY WILL IT TAKE TO START A WHEELCHAIR MANUFACTURING BUSINESS?

Starting a wheelchair manufacturing business from scratch (with nothing donated) that can manufacture between 10 and 15 wheelchairs a month will require an initial investment of between \$9,700 and \$11,300. This figure is based on 1984 prices and will vary from one country to another.

CAPITAL REQUIREMENTS	LOW	HIGH
Basic Tool Kit	\$1,000	\$1,000
Other Tools, Equipment, and Machinery	2,900	2,900
Start-Up Costs	800	2,400
Operating Capital (direct costsof two months production)	5,000	5,000
	<i>\$9,700</i>	<i>\$11,300</i>



Detailed price lists of all the tools, machinery, and materials are found in Chapter 2.

Start-up costs should cover all expenses until the shop begins to sell wheelchairs. It will probably take six months or more before sales are large enough to cover all expenses. Start-up costs can include modifying the shop and office to make them wheelchair accessible, installing electric circuits, bending equipment, and other machinery, incorporating and setting up financial records, training the staff, and many other items. Start-up costs will vary greatly from one group to the next, and are easy to underestimate.

Operating capital is money used to purchase materials in large quantities and to provide an ongoing cash reserve to protect the business during dry spells. Many small businesses fail because they try to begin manufacturing before they have raised enough money. Accurately projecting how much capital the business will need, and then raising the full amount, are two of the most important steps to take to insure the health and survival of your new business.

There are several ways to go about raising capital. If the business is set up as a charitable organization some of the money can be raised through donations, either from private individuals or from foundations. However, both nonprofit and profit-making enterprises are likely to raise most of the money through bank loans, private investors, or some combination of the two. Any lending agency will want to look at a well thought out business plan before loaning money. The following analysis of how much it costs to manufacture one wheelchair and the list of potential expenses should help you to begin to develop your business plan.

## **ESTIMATED COST PER WHEELCHAIR**

It is important when calculating what it costs to produce a wheelchair to include the indirect costs such as shop rental, utilities, truck rental, etc., as well as the direct and obvious costs of materials, a mechanic's labor, and finishing (chrome plating and painting). Two of the indirect costs that many groups forget to include are equipment depreciation and debt retirement.

### **Equipment Depreciation**

Tools, machinery, jigs, and equipment will not last forever. At some point your business will need to buy new ones. If your saber saw is expected to last for two years of hard use, and it initially cost \$24, it will depreciate at a rate of \$1.00 per month. This \$1.00 per month is an expense that must be added into your calculations of what it actually costs to make wheelchairs. Considering that your initial investment in tools, jigs, machinery and equipment may be close to \$4,000, it is important to calculate how quickly these various items are likely to depreciate. No one wants to use up the life of their tools and not have any money set aside to buy new ones. From

our experience we estimate that by setting aside \$110 a month as a depreciation expense, the business will have enough money saved to replace the jigs, equipment, and machinery as needed. Placing these funds in a savings account will also earn the business some interest which can help to cover the increase in prices due to inflation.

## Debt Retirement and Interest (Paying back a Loan)

In calculating the expected cost per chair, we have assumed that the total capital investment of \$11,300 was borrowed at a interest rate of 18% over a period of three years. This results in a monthly payment of \$409. This figure will vary from one group to the next. Some groups will not need to borrow this much money (they may already have an established metal shop), and finance terms are likely to vary a good deal from one country to another. Be sure to use your actual figures to calculate your expected cost per chair.

The following chart is based on the first year's operation of the wheelchair factory of Asociacion Del Rehabilitacion Del Impedido De Asuncion, Paraguay. They have established a business with three mechanics producing 12 chairs a month; we have applied those figures to a four worker shop producing 14 chairs per month. This is 78% of a typical production capacity of 18 chairs per month. Fill in the blanks with the figures from your particular country and situation to estimate your own costs.

<b>DIRECT COSTS PER WHEELCHAIR:</b>		
Materials	\$ 84	
Labor (40 hours at \$0.75 per hour)	30	
Finishing (chrome plating parts of the chair and painting the rest)	15	
<b>TOTAL DIRECT COSTS</b>	<b>\$129</b>	
<b>INDIRECT COSTS PER MONTH:</b>		
Rent	\$160	
Administrative Wage (160 hours at \$0.75 per hour)	120	
Accountant's Labor (16 hours at \$3.00 per hour)	48	
Transportation (truck rental)	40	
Electricity	7	
Water	5	
Depreciation (Machinery, Tools, Jigs, Equipment)	109	
Equipment Maintenance	15	
Debt Retirement and Interest	409	
Office Expenses	8	
Phone	13	
Taxes	12	
<b>TOTAL INDIRECT COSTS PER MONTH</b>	<b>\$946</b>	
<b>INDIRECT COSTS PER WHEELCHAIR</b>	<b>\$ 68</b>	

(indirect costs per month divided by the number of chairs produced per month)		
<b>TOTAL ESTIMATED COST PER WHEELCHAIR</b>	<b>\$197</b>	

Locally produced wheelchairs using old-style, heavy frames that lack important features sell in several countries for \$200 to \$400. Locally produced imitations of Everest and Jennings chairs sell in some places for \$300-\$600, and full-featured imports sell for \$600-\$1500. Our Torbellino wheelchair, a full featured lightweight chair selling for \$200 to \$250, has sold quickly in these markets.

## CUSTOMERS

Unfortunately, \$200 to \$250 is still more than many people will be able to afford. It is important before beginning production to determine if the people who need chairs in your area will be able to buy the chairs you produce or will be able to get a loan to buy them. If adequate consumer credit is not available, you may need to come up with some funds of your own. The Philippine group has hired a salesperson who travels throughout the area visiting customers, and when possible, arranging for donors to help pay for chairs for some of the poorer customers.

Some groups have considered providing consumer financing, but at this time, none have had large enough financial reserves to do this. One possibility is the establishment of a revolving fund for consumer credit. The maintenance of the fund would be based on the likelihood that disabled people who are currently underemployed could earn a better living once they have better mobility. Thus, they could maintain a reasonable schedule of payments, and the money could be used again for consumer credit. The money for this fund might come from a charitable contribution, or be built up slowly from the profits from sales of wheelchairs to other customers.

[Table of Contents](#)

# Center for International Rehabilitation

## Chapter 2 Tools and Shop Facilities

This chapter includes descriptions and prices of the tools, machinery, and shop equipment that you will need to manufacture the ATI-Hotchkiss Torbellino wheelchair. It also includes information on how to set up a safe, efficient, and accessible shop.

The Torbellino (Whirlwind) wheelchair has been designed so that it can be built using low cost tools and machinery, most of which can be purchased locally. While the tools available locally will vary from one country to the next, there are some tools that have been consistently difficult to find.

A Basic Tool Kit is available from Appropriate Technology International which includes the hand tools that are often difficult to purchase locally plus two different tubing benders, a sample fender, brake, and footrest (wheelchair parts that can be difficult to bend accurately), and a complete set of the jigs that we have found to be most useful. The Basic Tool Kit can be purchased for approximately \$1000 (U.S.) from Appropriate Technology International. A detailed list of the contents of the Basic Tool Kit, prices, and ordering instructions can be found later in this chapter.

## TOOLS AND MACHINERY

All the tools and machinery needed to equip a shop are listed below accompanied by pictures and descriptions. Items that are included in the Basic Tool Kit are identified with an asterisk (\*). When we suspect that it may be difficult to find a certain tool locally, we have included the name and address of a company that sells it (in case you would prefer to order directly from the manufacturer).

### MACHINERY

#### 1) Tubing, Rod, and Bar Bender\*

Bending steel tubing, rod, and bar accurately and smoothly are some of the most important tasks of a wheelchair maker. Building the Torbellino wheelchair involves making many bends with a small radius. Only a good bender with well formed dies can make these bends without wrinkling the tubing.

The best type of bender we know of for local wheelchair manufacture is one made by the Hossfeld Company in Winona, Minnesota, U.S.A. This bender makes a tighter and stronger bend than most benders of comparable cost.

The Hossfeld bender has two basic parts, the bending frame and the die sets. One arm of the frame is mounted on the work bench while the other arm pivots inside it, pulling the tubing, bar, or rod around the form die.

It is possible to make a bender frame that works as well as the Hossfeld frame for a fraction of the cost. Directions and diagrams for making a bender frame that can be used with Hossfeld dies and bending parts can be found in Appendix A at the end of this book. This frame can also be purchased as part of the Basic Tool Kit. Since the dies must be very precisely made in order to bend tubing without wrinkling it, we recommend that you buy the Hossfeld dies and bending parts. The Hossfeld dies and bending parts used in manufacturing the ATI-Hotchkiss chair are included in the Basic Tool Kit. If you prefer to order the dies and bending parts directly from Hossfeld, use the list of parts in the Basic Tool Kit found later in this chapter to help you order.

Hossfeld Manufacturing Co.  
Box 557  
Winona, Minnesota 55987  
U.S.A.

## 2) Wooden Tubing Bender and Dies\*

This bender has been designed to form the large radius bends used in making the fenders and handrims. Instructions for making this bender can be found in Appendix A.

## 3) Welding Equipment

We have chosen to use the oxygen-acetylene torch because it is the only low cost welder that is well suited to all the welds on a lightweight steel wheelchair. You will need a complete set of oxyacetylene welding tools including regulators, hoses, torch, tips, a striker, a mask, and goggles.

Electric arc welding can also be useful for the heavier weld such as on the caster fork. It is not recommended for lightweight steel tubing; electric welds are more likely to crack under heavy use.

## 4) Gas Tanks (Acetylene and Oxygen)

## 5) Drill Press

Use a bench height drill press. By setting it on a low table, it will be the right height for a worker who rides a wheelchair. The drill press should be either 1/2 or 3/4 horse power. It should have a rotating table which can be raised or lowered with a hand crank. In many countries, some of the least expensive drill presses are of excellent quality; nevertheless, we have often needed to replace the chuck (the part that holds the drill bit).

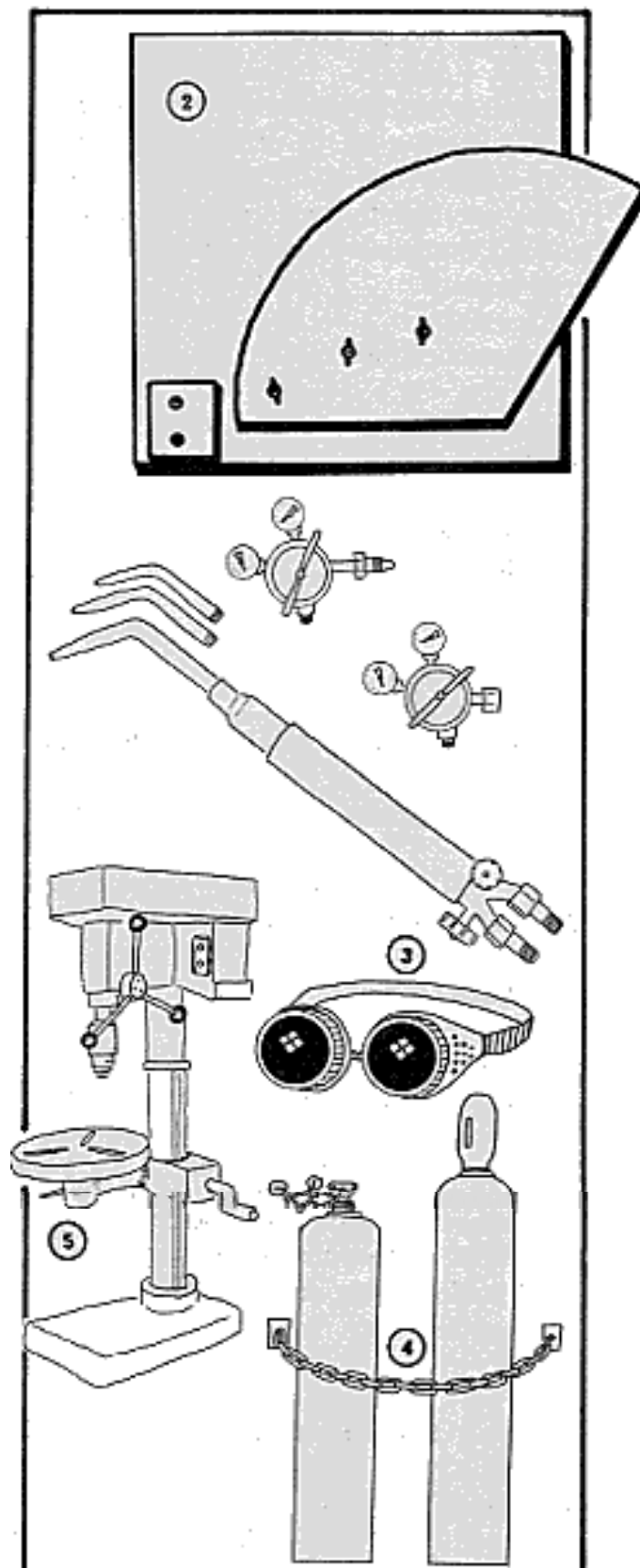

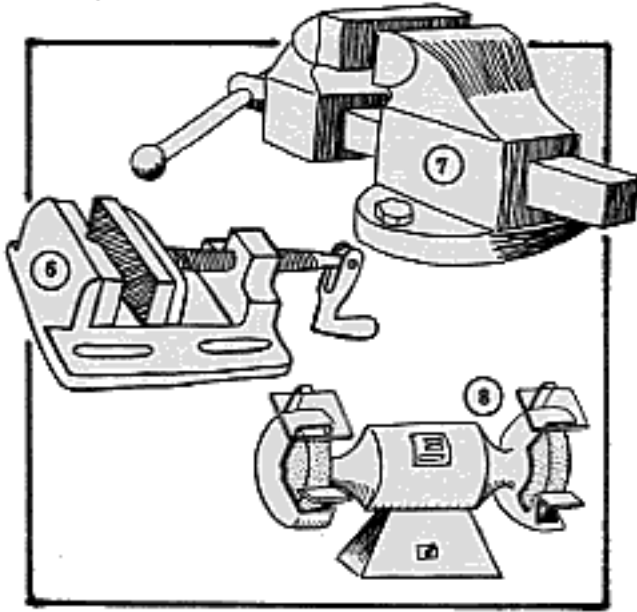

#### 6) Drill Press Vise

Without a drill press vise, you are likely to break off a lot of drill bits. If your tool dealer doesn't carry this type of vises, ask him to order some. They are sold by the same manufacturers that sell drill presses.

#### 7) Bench Visers

These should have a jaw width of from 3" (75 mm) to 5" (125 mm).

#### 8) Grinder

8" (200 mm) wheel, 3250 rpm

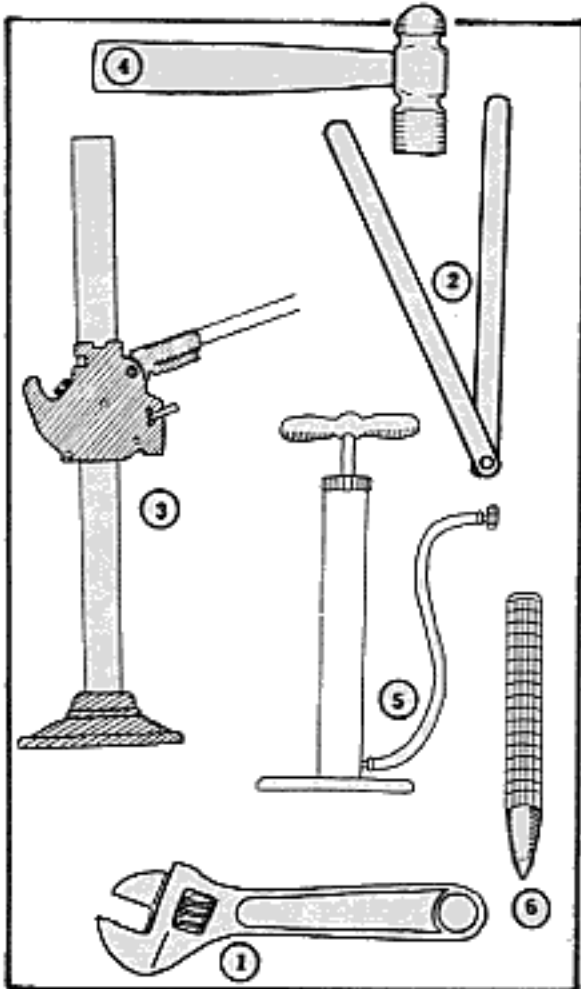

### HAND TOOLS

#### 1) 8" (200 mm) Adjustable Wrench

#### 2) Angle Measuring Tool

Make this simple tool yourself (see Chapter 6 and Appendix B).

#### 3) Auto Jack

Use a ratchet jack (the kind that would come with any large American car). This jack is used to help bend the larger tubing (7/8"). To attach it to your tubing bender, drill a 1/2" (13 mm) hole in the bottom end.

Descriptions of how to attach it to your bender and how to bend tubing using this method are found in Chapter 6.

#### 4) Ball Peen Hammer

#### 5) Bicycle Pump

#### 6) Center Punch



7) C-Clamps 3" (75 mm), 4" (100 mm), and 6" (150 mm)

8) Electric Hand Drills

9) Extension Cords with Adapters

10) Hacksaws

11) Hold Down Clamp

If you have trouble finding one, you can make your own by cutting a C-clamp in half and welding a plate on the bottom so that the clamp can be bolted to a table.

12) Knife

13) Leather Gloves (for welding)

14) Leather Punch (for 3/16" [5 mm] hole)

15) Leather Tool Aprons

16) Monkey Wrench

17) Pliers

18) Channel Lock Pliers

19) Safety Glasses or Goggles

Safety glasses or goggles are **ABSOLUTELY NECESSARY** whenever a worker is using the grinding wheel, drill, or any other tool that shoots out metal particles.

20) Saber Saw with Blades

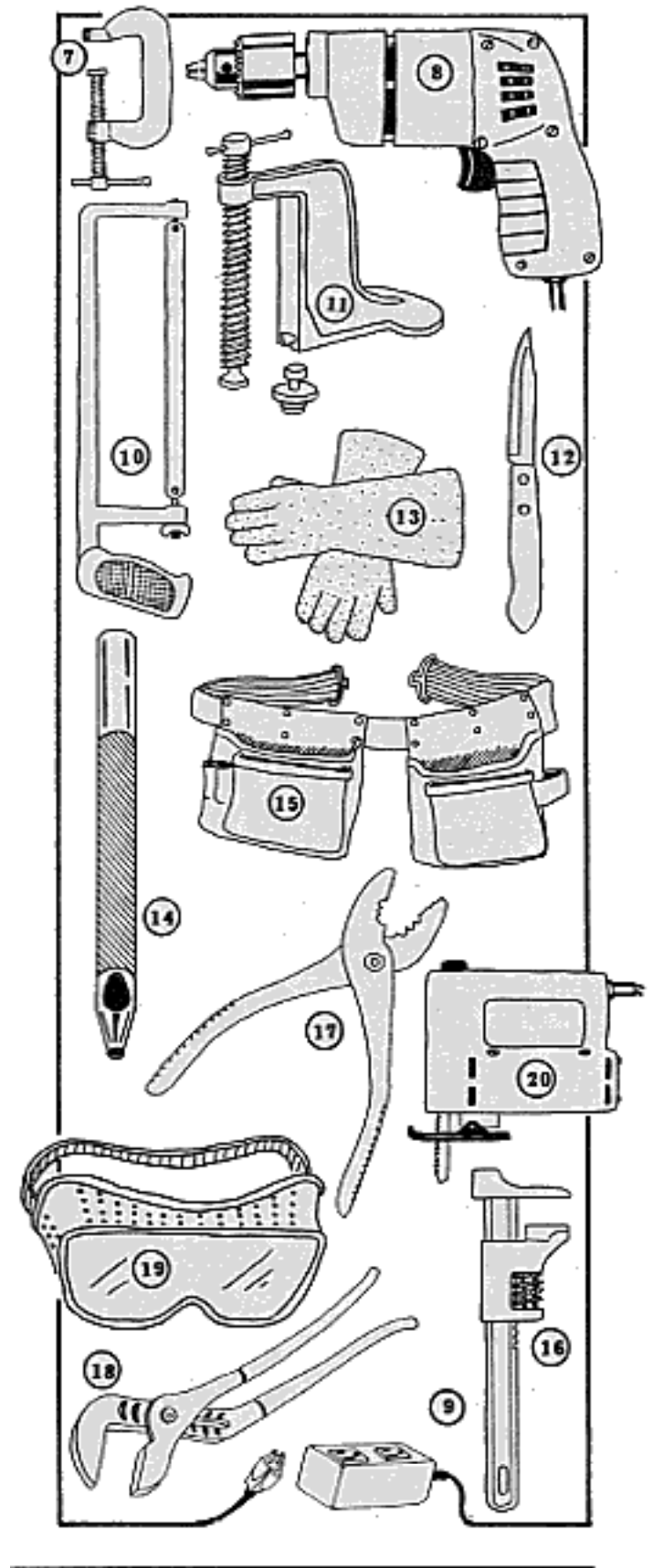

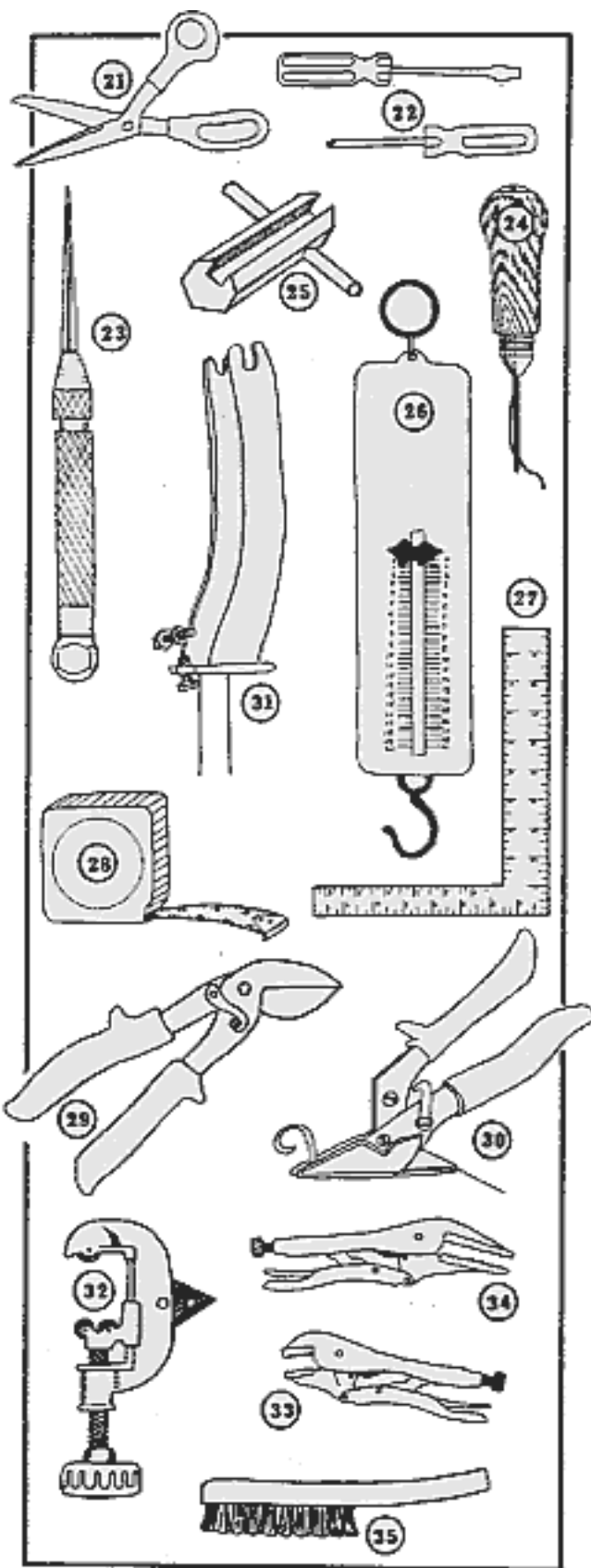

21) Scissors

22) Screwdrivers (slotted and Phillips)

23) Scribes (for marking steel)

24) Sewing Awl

Use a hand awl with an industrial sewing machine needle in it.

25) Spoke Keys

26) Spring Scale (0-40 lbs [0-20 kg])

27) Squares

28) Tapemeasures

29) Tinsnips (offset)

30) Tinsnips (slitting)

31) Truing Stand

Use an old bicycle fork with nuts welded to it. Insert bolts through the nuts and adjust them to the desired length. They will serve as guides to sight against when truing the wheel.

32) Tubing Cutter

33) Vise Grips

34) Vise Grips (long nose)

35) Wire Brush

Use the brush to clean surfaces before and after welding.

## HAND TOOLS THAT MAY BE HARD TO FIND

### 1) Angle Level\*

This is a combination of a level and a protractor. A protractor alone will serve, but the angle level can measure angles more easily. One company that makes and sells this tool is:

Mayes Brothers Tools  
Johnson City, Tennessee 37601  
U.S.A.

### 2) Circle Cutter\* (for cutting circles out of wood)

### 3) Protractors\* (used for measuring angles)

4) Reamers\* 1/8" (3 mm) - 1/2" (13 mm) range. These are used to enlarge and smooth holes in metal.

5) Vernier Calipers\* (Metric/English) These should be capable of accurately measuring the inside and outside diameter of tubing and the depth of holes. The circle cutter, protractor, reamer, vernier calipers can be ordered from:

General Hardware Mfg. Co., Inc.  
80 White St.  
New York, New York 10013

### 6) Tubing Cutter\*

Model #20 made by: Ridge Tools  
400 Clark St.  
Elyria, Ohio 44036  
U.S.A.

### 7) Indenting Wheel\*

Made by local machinist.

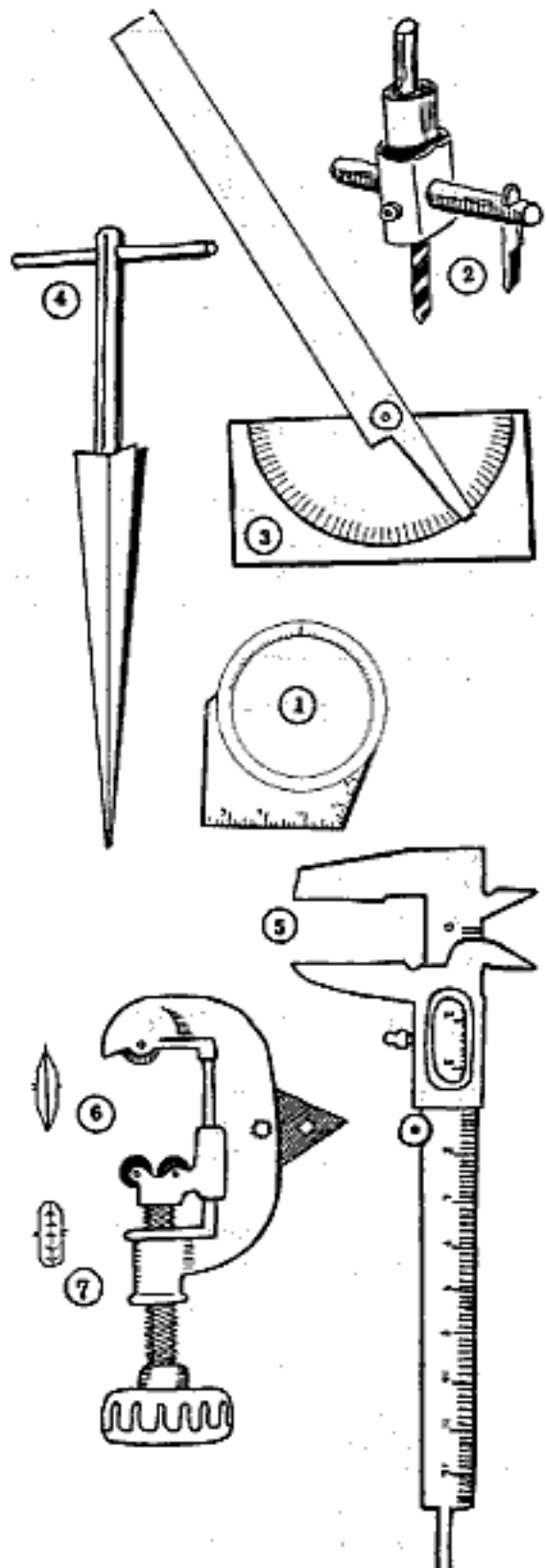

# CONTENTS OF THE BASIC TOOL KIT

The Basic Tool Kit can be purchased through A.T. International. The price is currently \$1000 U.S. with shipping to most countries. This price is subject to change if costs or the contents of the tool kit change. The Basic Tool Kit is made up of four separate tool sets: the hand tools, the commercial bending tools, the ATI bending tools, and the jigs and sample parts. It is possible to purchase one or more of these tool sets separately. Unfortunately, we are not yet capable of breaking up these sets to sell tools or jigs individually. We have listed the individual prices of the hand tools to allow you to compare prices.

To order the Basic Tool Kit or one or more of its four tool sets, write to:

AT International, 1331 H Street, Washington D.C. 20005, U.S.A.

The Basic Tool Kit from Appropriate Technology International includes the following items. It is possible to make most of the jigs and some of the bending tools locally. In Appendix A and B we have included instructions for making the jigs and tools on this list that have been marked with an asterisk (\*).

<b>1) HAND TOOLS:</b>	<b>\$90.00</b>
Angle Level	\$8
Circle Cutter	11
Protractor	8
Reamer	8
Tubing Cutter with Indenting Wheel	45
Vernier Calipers	10
<b>2) COMMERCIAL BENDING TOOLS</b>	<b>\$200.00</b>
Hossfeld Tubing Bending Die Sets	
3/4" Outside Diameter, 1-7/8" Center Line Radius	
7/8" Outside Diameter, 2" Center Line Radius	
Hossfeld Miscellaneous Bar and Rod Bending Parts	
Flat Head Pin	
Center Pin for 1/2", 5/8" and 3/4" eyes	
Eye Pin	
"U" Shaped Pin with lug for small eyes	
Bending Dog	
"U" Pin Roller	
Thumb Nut	
"U" Pin Support Plate	

## Center Pin Support Plate

3) ATI BENDING TOOLS (use with Hossfeld dies) \$100.00

\*Bender Frame

\*Caster Fork Die (2 3/8" O.D. x 3/4" I.D.)

4) JIGS, WOODEN BENDER, AND SAMPLE PARTS \$550.00

Sample Parts: Fender, Brake, and Folding Footrest

\*Wooden Tubing Bender with Fender and Handrim Dies

\*A Complete Set of Jigs (18)

(See Chapter 3 for a complete discussion and list of jigs.)

TOTAL COST OF BASIC TOOL KIT \$940.00

(All of the prices listed above are subject to change and do not include shipping fees.)

## PRICE LISTS

The following price lists were based on the quantities of tools, machinery, and shop equipment that would be needed to equip a wheelchair manufacturing business employing four people, three of whom are mechanics. The prices listed are approximate and are based on 1985 U.S. dollars.

As the tools and machinery that can be purchased as part of the Basic Tool Kit have already been listed above, they are not included in the following lists.

<b>MACHINERY</b>	<b>Quantity</b>	<b>\$/Unit</b>	<b>Total \$</b>
Bench Vises	2	55	110
Drill Press	1	350	350
Drill Press Vises	2	12	24
Gas Tank, Acetylene	1	80	80
Gas Tank, Oxygen	1	120	120
Grinder	1	120	120
Welding Equipment	1	240	240
<b>MACHINERY TOTAL</b>			<b>\$1,044</b>

<b>HAND TOOLS</b>	<b>Quantity</b>	<b>\$/Unit</b>	<b>Total \$</b>
Adjustable Wrenches (8" [200 mm])	4	8	32
Angle Measuring Tool	1	0	0
Auto Jack (for tubing bender)	1	25	25
Ball Peen Hammer	3	7	21
Bicycle Pump	1	6	6
C-Clamps 3" (75 mm), 4" (100 mm) and 6" (150 mm)	16	5	80
Drills, Electric hand	2	80	160
Extension cords w/adapters	2	5	10
Hack Saw	2	6	12
Hold-down Clamp	1	8	8
Knife	1	10	10
Leather Gloves	1	6	6
Leather Punch (3/16" [5 mm])	2	7	14
Leather Tool Aprons	3	6	18
Monkey Wrench	1	14	14
Pliers	3	6	18
Pliers, Channel type	1	11	11
Saber Saw w/blades	1	26	26
Safety Glasses	3	6	18
Scissors	1	8	8
Screwdrivers (slotted)	8	8	8
Scribes	3	3	3
Sewing Awl	1	6	6
Spoke Keys	1	3	3
Spring Scales (0-40 lbs [0-20 kg])	1	60	60
Squares	3	7	21
Tape Measures	3	5	15
Tinsnips (Slitting and Offset)	2	16	32
Truing Stand	1	0	0
Tubing Cutter	2	45	90
Vise Grips (regular)	2	10	20



Vise Grips (needle nose)	1	10	10
<b>HAND TOOLS TOTAL</b>			<b>\$765</b>

## SHOP FACILITIES AND EQUIPMENT

SHOP EQUIPMENT	Quantity	\$/Unit	Total \$
Cardboard Boxes for Parts	30	0	0
Chairs	2	10	20
Fans (1 large, 1 small)	2	70	140
Fire Extinguishers (ABC)	2	50	100
First-Aid Kit	1	50	50
Janitorial Equipment (brooms and metal garbage cans with lids)	1	50	50
Office Furniture (Used)	1	80	80
Shelving	1	20	20
Steel Rack	1	50	50
Work Benches, 3 wood and 1 steel	4	140	560
<b>EQUIPMENT TOTAL</b>			<b>\$1,070</b>

A good shop is one that is safe, well organized, and accessible to both disabled and non-disabled workers. Every shop needs a fire extinguisher. The dry powder type (ABC) will put out electrical, wood, and grease fires. To help prevent fires, be sure to use metal garbage cans *with lids* for greasy rags and other flammable refuse. Your shop will also need adequate ventilation. Welding is best done outdoors; a couple of fans may also be necessary to draw fresh air in and blow the fumes and hot air out.

A list follows of what your first aid kit should contain. Keep it well stocked and within easy reach at all times.

### FIRST-AID KIT CONTENTS

- Sterile gauze pads
- Assortment of finger sized bandages
- 1, 2, and 3" gauze bandage rolls
- Clean cotton
- Adhesive tape (1" wide roll)
- Disinfectant soap
- 70% alcohol

Hydrogen peroxide  
Petroleum jelly (Vaseline)  
Scissors  
Needle  
Tweezers with pointed ends  
Aspirin  
Triangular bandage

## **ORGANIZATION**

It is easy to waste a lot of time searching for the part, bolt, or tool that you need. We recommend that you use separate, labeled cardboard or wooden boxes to store each individual part and a wooden rack to store and organize the tubing. Once the shop is well established, different size wheelchair components can be made in large quantities and stored for custom assembly.

## **WHEELCHAIR ACCESSIBILITY**

Work benches should be constructed so that a wheelchair rider can work at them comfortably. Each work bench should be no more than 30" (74 cm) high with at least 26" (64 cm) of clearance on one side, allowing a wheelchair rider to pull up and under one side of the table. Since the work bench will be too low for some non-disabled workers to use comfortably while standing up, be sure to provide chairs for them to use. The benches should also be very heavy. The tubing bender will be mounted on one of the wooden work benches; therefore, this work bench should be heavy enough not to move when you are bending tubing.

Be sure to allot some money in your budget for modifications that may be necessary to make your shop fully wheelchair accessible (ramps, widened doors, access to the bathroom, etc.). Depending on the shop space you have chosen, accessibility modifications could cost more or less than the \$50.00 we have included in the budget.

[Table of Contents](#)

# Center for International Rehabilitation

## Chapter 3 Jigs



Juan Becerra of Peru Using a Sideframe Jig

Wheelchairs can be built much more quickly and accurately by using jigs to hold the parts in place and guide your tools. We have developed jigs for the more difficult steps of building our wheelchair. There are jigs that hold parts at the correct angles during welding, and jigs that guide the drill bits to space holes uniformly.

In our experience, an expert mechanic using a complete set of jigs to make several chairs at a time is able to manufacture a wheelchair in three or four person days, while a mechanic using only a few jigs can take a week or more to make one chair.

There are many different ways in which experienced mechanics build jigs. In every case, however, the jigs must be accurate, produce consistent parts efficiently, and stand up to heavy use. The designs we are offering are the best we have come up with so far; we would very much appreciate hearing from any readers who develop jigs which are more accurate or easier to make.

The amount of time it takes to build one chair can be reduced to a minimum when workers specialize, using jigs to build wheelchair parts in large quantities. Rather than each worker spending a lot of time each day changing tools and tasks, one can make wheels while another bends the sideframes and fenders; one can weld while another sews upholstery.

Our current set of jigs can be purchased as part of the Basic Tool Kit (described in the previous chapter). For those of you who can make the jigs yourselves or who know a local machinist who can make them, we have included diagrams and brief descriptions of each jig in Appendix B at the end of this book.

The following list is a complete list of all the jigs that we are now using to build the ATI-Hotchkiss wheelchair.

## A COMPLETE LIST OF JIGS

JIG	PART OF CHAIR	USED IN CHAPTER
1) Seat Back Drilling Jig	Sideframe	7
2) Frame Welding Jig	Sideframe	10
3) Plywood Square	Sideframe	10
4) Brake Hole Drilling Jig	Sideframe	7
5) Seat Support Tube Drilling Jig	X-Brace	9
6) X-Brace Brazing Jig	X-Brace	9
7) Center Hole Drilling Jig	X-Brace	9
8) Brake Catch and Stop Welding Jig	Fender Bar	8
9) Hub Drilling Jig	Rear Wheels	11
10) Spoking Board	Rear Wheels	11
11) Rim Drilling Jig	Handrim	12
12) Caster Fork Bending Die	Front Wheels	13
13) Caster Fork Brazing Jig	Front Wheels	13
14) Upper Tube Welding Jig	Folding Footrests	14
15) Upper Tube Drilling Jig	Folding Footrests	14
16) Lower Tube Drilling Jig	Folding Footrests	14
17) Stop Rod Welding Jig	Folding Footrests	14
18) Cotter Pin Hole Drilling Jig	Brakes	15
19) Edge Bar Drilling Jig	Seat and Back	16

We have included the following diagrams to give you an idea of what the various jigs actually look like. As you refine your production techniques, you will undoubtedly invent new jigs and refine old ones. For directions on how to make each jig see Appendix B at the end of this book.

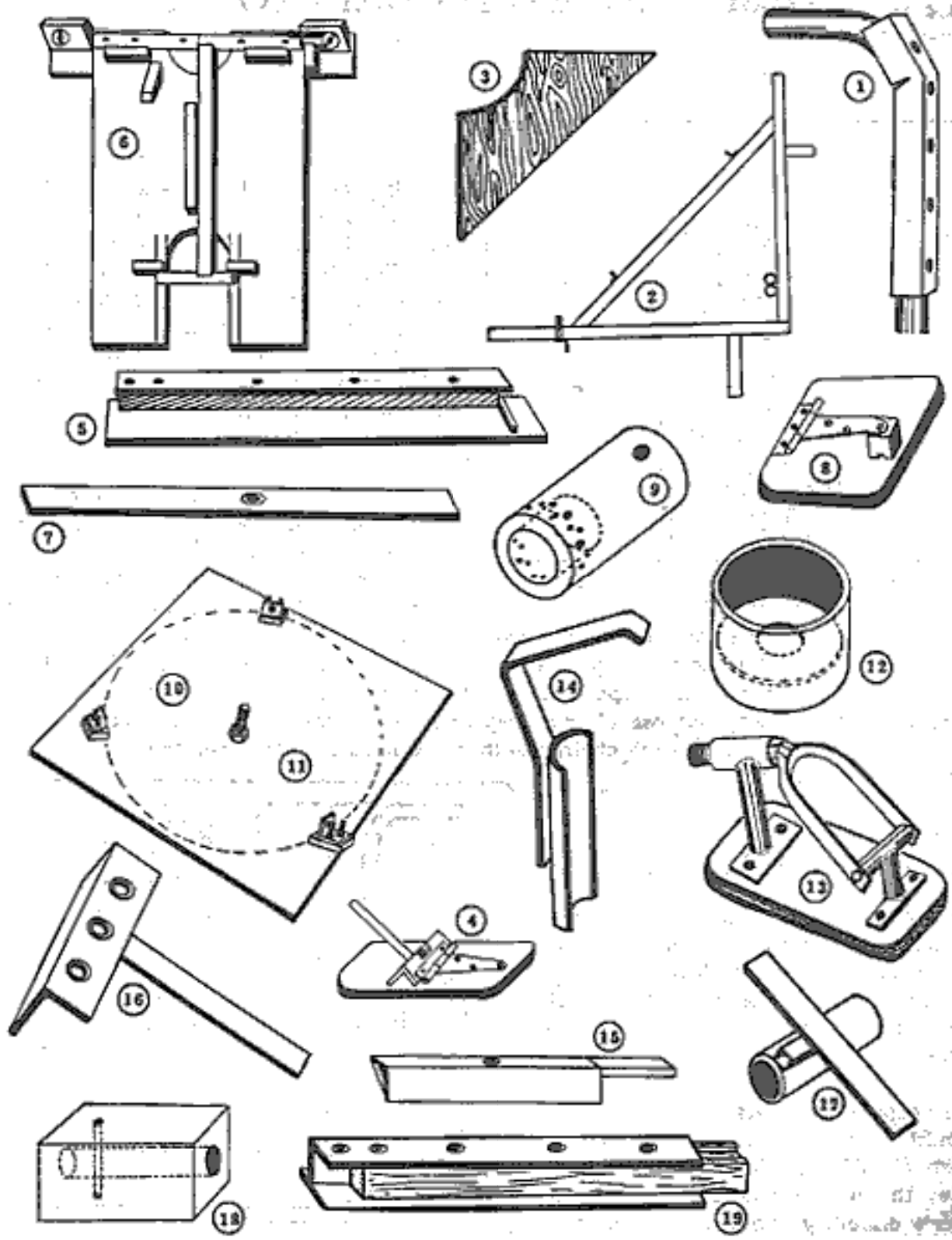

# Center for International Rehabilitation

## Chapter 4 Designing Each Chair to Fit

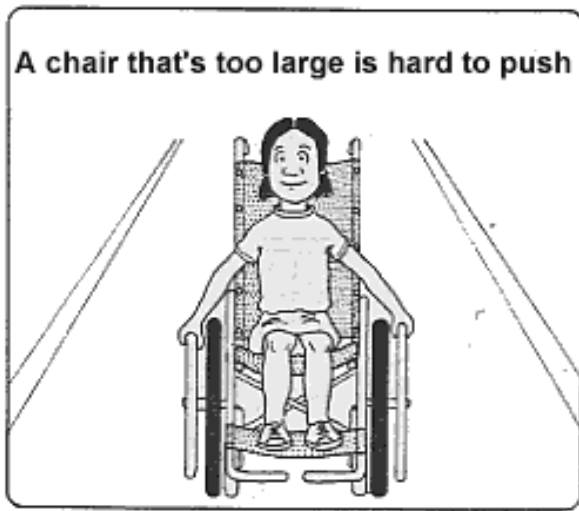

It is important that the wheelchair fit the needs of the rider. A customer's height, width, and level of disability will affect the design of the chair. How the customer intends to use the wheelchair will also affect the design. A customer who plans to race her chair will want a different chair from one who plans to ride his chair over rough and hilly terrain.

Before beginning to make a chair, you will need to decide how large to make the seat, how long to make the footrests, and what size of wheels and handrims will best serve the needs of a particular wheelchair rider. While we encourage you to make chairs that truly fit the customer, we do not mean to imply that you must make each chair one at a time. It is much better to make chair components in batches and assemble the appropriate sizes to order. The primary purpose of this chapter is to outline the various customizing decisions that will go into each chair, whether you mass produce components, or make each chair individually.

### FRAME HEIGHT AND LENGTH

The standard wheelchair is designed for all purpose use by a paraplegic who is 5'4" (1.63 m) tall; 24" (61 cm) is a standard height for the back of the frame; 17-1/2" (44.5 cm) is a standard frame length.

The height of the back of the wheelchair should be changed to accommodate the needs of different riders. As a general rule, the back should be as low as the rider's disability allows without being so low that it is difficult to pull the chair upstairs. Because of this, we recommend that the frame height not be any shorter than 22" (56 cm). Someone with a lower level of disability who has no difficulty balancing his or her upper body does not need as high a seat back as someone with quadraplegia. A well designed jig will accommodate different back heights easily.

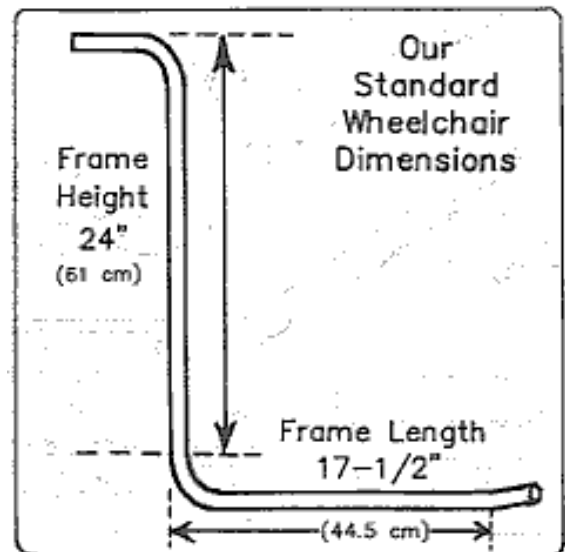



The frame length is more difficult to change. The frame cannot be any shorter without changing the design to include smaller front wheels. The frame can be lengthened for people who want to race their chairs or for very tall people who feel they need the extra stability. The disadvantage of a longer frame is that it is more difficult to maneuver indoors. In addition, our sideframe brazing jig would have to be lengthened in order to make a longer frame.

## SEAT HEIGHT AND WIDTH

The height and width of the seat can also be built to fit each individual rider. The seat should be high enough and the footrests low enough so that the rider's thighs press against the seat cushion. This will distribute the body weight, taking some weight off the buttocks and reducing the chances of getting pressure sores. The seat should also be low enough that the rider's feet are not left dangling. To find the appropriate seat height, measure from the back of the client's knee to the bottom of his heel. Add two inches (5 cm) to that measurement in order to allow enough room for the footrests to clear the ground. The resulting measurement is the seat height. It measures the distance from the ground to the front edge of the seat.

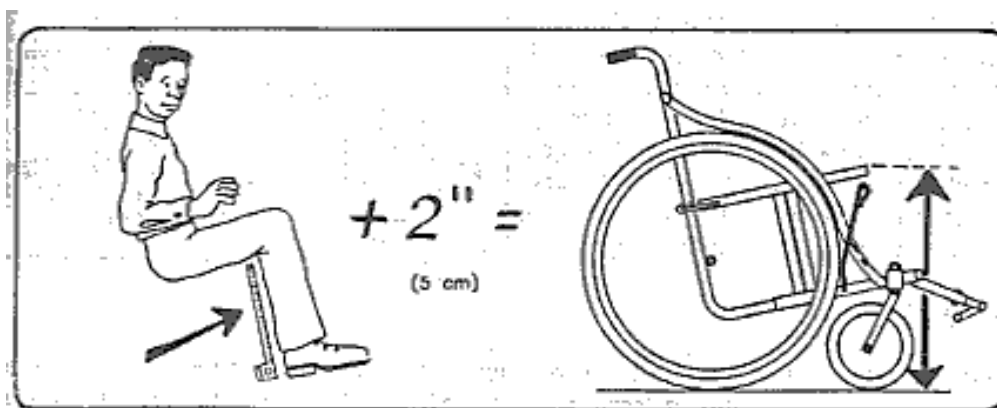

As a general rule, the following table will give you an idea of the seat height that is appropriate for people of different heights. If you are making a chair for an adult who is less than five feet tall (1.52 m), don't make the seat height any lower than 17- 1/2" (44.5 cm); just shorten the footrest to reach his feet. Wheelchairs with a seat height greater than 20" (51 cm) can be a bit top heavy and unsteady. It is also difficult to make a folding chair with a very high seat because the seat hooks will hit the fender when the chair is folded. Most riders who are more than 5'11" (1.80 m) tall prefer a seat no higher than 20" (51 cm) high. They add extra thickness to the front of their cushion to get additional seat height and thigh support without raising their whole body.

<b>BODY HEIGHT</b>	<b>MINIMUM SEAT HEIGHT INCLUDING CUSHION</b>
5' (1.52 m)	17-1/2" (44.4 cm)
5'2" (1.57 m)	18" (45.7 cm)
5'4" (1.63 m)	18-1/2" (46.9 cm)
5'6" (1.68 m)	19" (48.2 cm)
5'8" (1.73 m)	19-1/2" (49.5 cm)
5'10" (1.78 m)	20" (50.8 cm)
6' (1.83 m)	20-1/2" (52.0 cm)
6'2" (1.88 m)	21" (53.3 cm)
6'4" (1.93 m)	21-1/2" (54.6 cm)

The narrower the wheelchair, the more places the rider can go; consequently, the wheelchair should be made as narrow as possible while still leaving enough room for comfort. To find the appropriate seat width, have your customer sit in a wheelchair that is larger than she is. Slide books in on either side of her until the books just touch but aren't squeezing her hips. A seat this wide will give most riders enough room to move while still keeping the chair reasonably narrow. Measure the distance between the two books and use this measurement for the width of the seat and seat back upholstery.

## **SEAT ANGLE**

In our wheelchair design the seat and back recline 12°. An occasional customer will want a chair that is reclined less. Quadraplegics, and others who have trouble sitting up straight, may want the seat to recline further. Changing the angle of the seat will require making the wheelchair by hand or using a modified sideframe jig.

## **X-BRACE LENGTH**

The length of the x-brace is determined by the height and width of the seat. The following table can be used to calculate the length of the x-brace. The measurements listed for the x-brace give the length of the tubing before it is filed to fit around the pivoting tube and seat support tube. (See Chapter 8).

## SEAT HEIGHT AND WIDTH DETERMINE X-BRACE LENGTH

SEAT WIDTH	SEAT HEIGHT AT FRONT OF SEAT	X-BRACE LENGTH
13" (33.0 cm)	18" (45.7 cm)	15" (38.1 cm)
13" (33.0 cm)	19-1/2" (49.5 cm)	16" (40.6 cm)
13" (33.0 cm)	21" (53.3 cm)	17" (43.1 cm)
14" (35.5 cm)	18-1/2" (46.9 cm)	16" (40.6 cm)
14" (35.5 cm)	20" (50.8 cm)	17" (43.1 cm)
14" (35.5 cm)	21-1/2" (54.6 cm)	18" (45.7 cm)
15" (38.1 cm)	18-1/2" (46.9 cm)	17" (43.1 cm)
15" (38.1 cm)	20" (50.8 cm)	18" (45.7 cm)
15" (38.1 cm)	21-1/2" (54.6 cm)	19" (48.2 cm)
16" (40.6 cm)	19" (48.2 cm)	18" (45.7 cm)
16" (40.6 cm)	20-1/2" (52.0 cm)	19" (48.2 cm)
16" (40.6 cm)	22" (55.8 cm)	20" (50.8 cm)**
17" (43.1 cm)	17" (43.1 cm)*	18" (45.7 cm)
17" (43.1 cm)	19" (48.2 cm)	19" (48.2 cm)
17" (43.1 cm)	21" (53.3 cm)	20" (50.8 cm)**
17" (43.1 cm)	22-1/2" (57.1 cm)	21" (53.3 cm)**
18" (45.7 cm)	17" (43.1 cm)*	19" (48.2 cm)
18" (45.7 cm)	19-1/2" (49.5 cm)	20" (50.8 cm)**
18" (45.7 cm)	21" (53.3 cm)	21" (53.3 cm)**
19" (48.2 cm)	17-1/2" (44.4 cm)*	20" (50.8 cm)**
19" (48.2 cm)	19-1/2" (49.5 cm)	21" (53.3 cm)**
19" (48.2 cm)	21-1/2" (54.6 cm)	22" (55.8 cm)**
20" (50.8 cm)	18" (45.7 cm)	21" (53.3 cm)**
20" (50.8 cm)	20" (50.8 cm)	22" (55.8 cm)**

\* These seat heights (measured at the front of the seat tubes) are too low for chairs with 26" wheels; the seat hooks may hit the axle sockets. Minimum seat heights: for 24" wheels is 17"; for 26" wheels is 18". For children use a smaller rear wheel.

\*\* The longer x-brace lengths may cause the seat hook to bump against the top of the fender bar as the chair is folded, preventing the chair from folding all the way. This problem can be solved by using a longer fender that is welded to the frame at a point higher than the standard fender.

## LENGTH OF UPPER FOOTREST TUBE

The standard length for an upper footrest tube is 5-1/2" (14 cm). Since we have designed the footrest to be adjustable, most people should be able to adjust the standard size to fit. If someone needs a longer footrest, try using the 7-1/2" (19 cm) upper footrest tube. The best way to know whether the customer will need the longer size is to have him sit in an already completed wheelchair and see if his knees are raised too high.

## LENGTH OF LOWER FOOTREST TUBE

To fit a chair with a seat that is 16" (40.6 cm) wide, the lower footrest tubes should be bent out of two 21" (53.3 cm) lengths of tubing. For seats wider than 16" (40.6 cm), add 1/2" (1.3 cm) to the length of each piece of tubing.

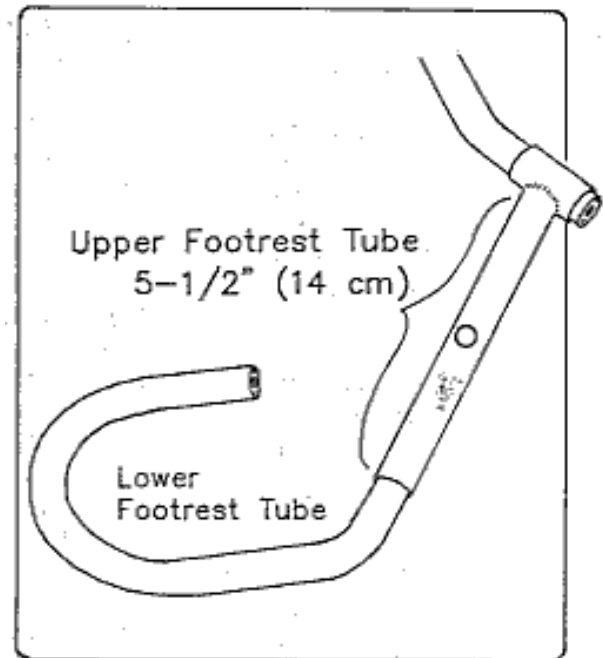

## HANDRIM DIAMETER

A larger handrim can give more pushing force to the wheel; a smaller handrim can push the wheelchair faster on level ground. The diameter of our standard sized handrim is about 6" (15.2 cm) smaller than the diameter of the wheel. Athletes who will be racing on level ground will probably want a handrim of a smaller diameter. A customer with limited arm strength who lives in a hilly area may want a handrim nearly equal in diameter to the wheel. Making a larger or smaller handrim will require making an appropriate sized die for the wooden bender (see Appendix A).

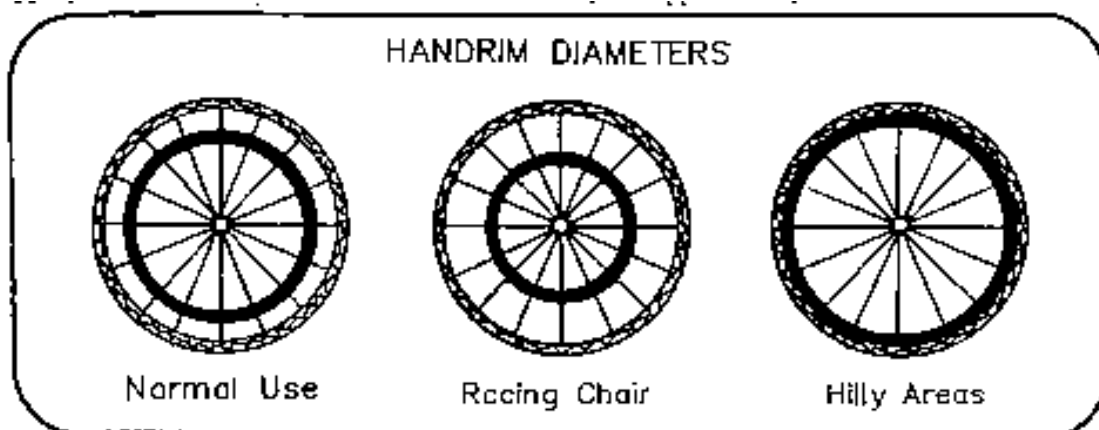

# CHOOSING THE REAR WHEEL SIZE

Our wheelchair design uses bicycle rims and tires instead of the solid rubber tires used on conventional wheelchairs. Not only are bicycle tires more readily available, but they give a much smoother ride and are easier to push.

Choose the wheel size (the diameter and width) based on the kind of use the chair is likely to get and on the sizes that are available. The most common wheel size for general use, especially for in town riding, is the 24" by 1-3/8" pneumatic bicycle wheel and tire. A 26" by 1-3/8" wheel can also be used if the 24" wheel is not available or is too expensive. For small children a 16" or 20" wheel is often better, because it lowers the rider to the eye level of other children.

For country or farm use, a wider wheel is better. It will give the wheelchair rider more traction; this means less time stuck in the mud! A 26" by 1.75" or a 26" by 2.125" wheel is a very good size for country use. A 24" wheel is also fine, but it is unusual to find one with the wider widths. Combining a rim that is 1.75" wide with a tire that is 2.125" wide will weigh less and work well.



# CUSTOMIZING THE WHEELCHAIR

Whether your shop mass produces components in different sizes and assembles chairs to order or makes each chair individually, you will need some kind of system to keep track of the measurements needed on each individual customer's chair.

We recommend keeping a file card or sheet on the customer that includes the following information:

# CUSTOMER INFORMATION SHEET

CUSTOMER'S  
NAME \_\_\_\_\_

ADDRESS \_\_\_\_\_

EXPECTED  
CHAIR USE \_\_\_\_\_

LEVEL OF  
DISABILITY \_\_\_\_\_

CUSTOMER'S  
HEIGHT \_\_\_\_\_

FRAME HEIGHT \_\_\_\_\_

SEAT HEIGHT \_\_\_\_\_

SEAT WIDTH \_\_\_\_\_

UPPER  
FOOTREST  
TUBE LENGTH \_\_\_\_\_

LOWER  
FOOTREST  
TUBE LENGTH \_\_\_\_\_

X-BRACE  
LENGTH \_\_\_\_\_

REAR WHEEL  
TIRE SIZE \_\_\_\_\_

TYPE OF FRONT  
WHEEL & TIRE \_\_\_\_\_

PARTS OF  
FRAME TO BE  
PAINTED/COLOR \_\_\_\_\_

PARTS OF  
FRAME TO BE  
PLATED \_\_\_\_\_

TYPE & COLOR  
OF  
UPHOLSTERY  
FABRIC \_\_\_\_\_

## MODIFICATIONS REQUIRING HAND CONSTRUCTION OR SPECIAL JIGS

FRAME LENGTH \_\_\_\_\_

HANDRIM  
DIAMETER \_\_\_\_\_

SEAT ANGLE \_\_\_\_\_

OTHER SPECIAL  
FEATURES \_\_\_\_\_



# Center for International Rehabilitation

## Chapter 5 Parts and Materials



The ATI-Hotchkiss wheelchair has been designed to use inexpensive materials readily available in most cities that have small- and medium-scale manufacturing. This chapter begins with an itemized price list of the materials that go into one chair. Before taking this list and dashing off in a rush of enthusiasm to buy one wheelchair's worth of materials, be sure to read the rest of this chapter. It will describe in more detail some of the various choices you will have to make as you set out to purchase the materials. Since the tubing sizes that are available vary from one country to another, we have included a table of tubing sizes to help you choose appropriate tubing. There are several different combinations of tubing sizes that can be used in making the Torbellino wheelchair.

This chapter also lists the prices of the basic supplies that will be used up while building wheelchairs, such as paint, flux, files, and cutting oil. The prices listed in the following table are typical prices for small purchases in the United States; they can vary considerably from one country to another.

MATERIALS	Size	Metric Equivalent	\$/Unit	Quantity (per chair)	Cost (per chair)
Bolts, N.F.	3/16" x 5/8"	5mm x 16mm	.02	8	.16
Bolts, N.F.	3/16" x 1-1/2"	5mm x 35mm	.03	10	.30
Bolts, N.F.	3/16" x 2"	5mm x 50mm	.03	8	.24

Bolts, N.F.	5/16" x 1-1/4"	8mm x 35mm	.05	4	.20
Bolts, N.F.	5/16" x 3-1/2"	8mm x 90mm	.07	2	.14
Bolts, N.F.	3/8" x 3"	10mm x 20mm	.18	1	.18
Bolts, N.F.	5/8" x 2-1/2"	16mm x 65mm	.36	2	.72
Bolts, N.F.	5/8" x 5"	16mm x 130mm	.62	2	1.24
Nuts, Locking N.F.	3/16"	5mm	.03	26	.78
Nuts, Locking N.F.	5/16"	8mm	.06	6	.36
Nuts, Locking N.F.	3/8"	10mm	.10	6	.60
Nuts, Locking N.F.	5/8"	16mm	.40	4	1.60
Screws, sheet metal	3/4 x #12	5mm x 18mm	.04	10	.40
Washers	3/16" I.D.	5mm I.D.	.01	20	.20
Washers	5/16" I.D.	5mm I.D.	.01	22	.22
Washers	3/8" I.D.	10mm I.D.	.01	4	.04
Tubing, per foot*	3/4" x .049"	See Chart	.49	20	9.80
Tubing, per foot*	7/8" x .049"	for	.89	11	9.79
Tubing, per foot*	7/8" x .125"	Equivalent	1.48	.25	.37
Tubing, per foot*	1" x .049"	Sizes*	1.00	4.25	4.25
Tubing, per foot*	1" sq. x .049"		.60	3	1.80
Tubing, per foot*	1-1/2" x .065"		.80	.75	.60
Bar, round, plated	5/16" diameter	8mm diameter	.40	3	1.20
Bar, round, per foot	3/8" diameter	10mm diameter	.40	1.3	.52
Bar, flat, per foot	1/16" x 1/2"	1.5mm x 12mm	.19	5.3	1.01
Bar, flat, per foot	1/8" x 1/2"	3mm x 12mm	.14	2	.28
Bar, flat, per foot	1/4" x 3/4"	6mm x 18mm	.37	2	.74
Bearings, sealed ball**	#6202 or 5/8" x 1-3/8"	See Chart**	.90	12	10.80
Pins, cotter	1/8" x 1"	4mm x 25mm	.10	2	.20

Handgrips*	7/8" I.D.	whatever fits	.49	2	.98
Plywood, square foot	3/4"	18mm	.70	2	1.40
Canvas, per yard	60" wide	1.6mm wide	7.00	1	7.00
Thread, yards or meters	heavy nylon	heavy nylon	.01	24	.24
Webbing, per foot	2" wide	5cm wide	.25	2	.50
Tires, solid rubber	8" x 1" or 1-1/2"	200mm x 25mm or 37mm	1.50	2	3.00
Tires, bicycle***	24" x 1.375"	no equivalent	3.50	2	7.00
Tires, bicycle***	24" x 1.375"	no equivalent	1.60	2	3.20
Rims***	24" x 1.375"	no equivalent	4.60	2	9.20
Spokes***	10-5/8" x 0.080"	270mm x 2mm	.05	72	3.60
Bands***	5/8" x 70"	1.6cm x 175cm	.15	2	.30
<b>TOTAL MATERIALS</b>					<b>\$85.16</b>

\* Tubing sizes can vary depending on sizes available. For a description of how to measure tubing, [go here](#); for alternate tubing sizes, [go here](#); and for methods of shrinking and expanding tubing, [go here](#).

\*\* Other bearing sizes will work. See [Chapter 11](#).

\*\*\*Wheel size may vary. See [Chapter 4](#) for details.

## MILD STEEL TUBING

The frame, fenders, handrims, footrests, and x-brace of the Torbellino are all made from mild steel thin-wall tubing; they are *not* made from heavy water pipe. Finding the size of tubing that you need can be confusing at best. Tubing has three different dimensions that are important: the outside diameter (O.D.), the inside diameter (I.D.), and the thickness of the tubing walls (the gauge).

Diameter is another word for the distance across a circle. It is measured by the length of a straight line passing through the center of the circle. The two sections of tubing, shown in the diagram at the right, have an outside diameter of 1 inch; since they have different wall thicknesses (gauges), their inside diameters are different.

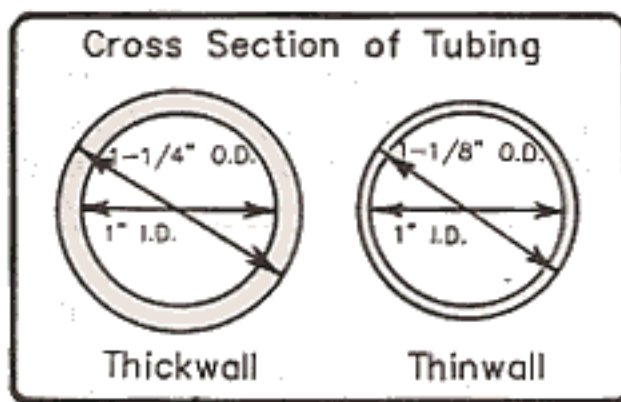

If three dimensions are not already enough to keep track of, there are also at least three different systems that are used to measure and describe tubing sizes:

- 1) inch-size steel tubing
- 2) thin-wallconduit
- 3) metric-sizesteel tubing

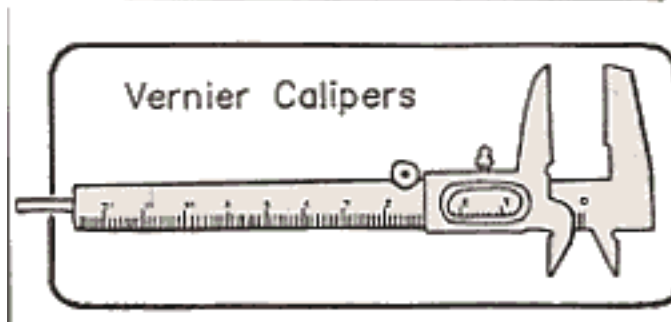

The types of tubing that are available vary from one country to the next and may even vary within a small area. For example, one can find inch size steel tubing in Culiacan, Mexico, whereas only 50 miles away in Mazatlan, metric size tubing is the only type available.

The actual size of conduit and water pipe is usually much larger than the size that is given when you buy it. So-called one inch conduit, for example, is actually 1.160 inch, or nearly 1-3/16 inch, in outside diameter. In order to know exactly what tubing you are getting, you will need to measure it yourself. **Don't buy tubing without measuring the outside diameter and the wall thickness with the vernier calipers and using the "Tubing Sizes" chart in this chapter.**

Finally, plan ahead before you buy tubing. In our wheelchair design, the pieces of tubing used in the bottom of the x-brace and in the top of the footrest must fit snugly over the sideframe tubing. Use the following charts of tubing sizes to help you decide which sizes of tubing to buy. If tubing is not available in the sizes you need, it may be necessary to reduce or expand the short pieces of tubing until they fit properly.

In Paraguay, for example, ARIFA is making the ATI design using 1" O.D. tubing for the side frames. Unfortunately, 1-1/8" O.D. tubing is not available for the outer tubes. The wheelchair makers in Paraguay solve this problem by using 1-1/4" O.D. tubing and reducing it until it fits snugly. They reduce the outer tubing by cutting it by hand, squeezing it, and welding it back together. Techniques for reducing and enlarging tubing are described in Chapter 6. Combinations of tubing sizes that work well are as follows:

### TUBING SIZES THAT PIVOT OVER THE WHEELCHAIR SIDEFRA

A SIDEFRA

WITH AN

FITS INTO AN X-BRACEMADE WITH  
TUBINGWHOSE

MADE OF THIS TUBE	OUTSIDE DIAMETER OF:	INSIDE DIAMETER IS:	SIZE DESIGNATION IS:
22 mm O.D.	0.867" O.D.	0.867" I.D.	25 mm O.D. x 1.5 mm wall
		0.870" I.D.	1" O.D. x 0.065" wall
7/8" O.D.	0.875" O.D.	0.902" I.D.	1" O.D. x 0.049" wall
"3/4 inch" conduit	0.925" O.D.	0.930" I.D.	1" O.D. x 0.035" wall*
25 mm O.D.	0.985" O.D.	0.995" I.D.	1-1/8" O.D. x 0.065" wall
1" O.D.	1.000" O.D.	1.027" I.D.	1-1/8" O.D. x 0.049" wall
		1.050" I.D.	"1 inch" conduit
		1.063" I.D.	30 mm O.D. x 1.5 mm wall

\* Mild (soft) steel tubing with a very thin wall of 0.035" (20 gauge or 0.9 mm) or a very thin wall of 1.0 mm (0.039") is sometimes available, but it should be used with great caution because it may be too weak. If it must be used for the pivoting tubes of an X-brace or footrest, the tubing joints should be reinforced with triangular braces and with wire or sheet metal wrapped around the ends of the pivoting tubes and brazed in place. We do not recommend tubing this light for sideframes; it is *very* difficult to bend and it may bend or crack in use. Extra thin wall tubing *does* make very good lightweight handrims.

## AVAILABLE SIZES OF LIGHTWEIGHT STEEL TUBING

The chart which follows lists in more detail the thinwall tubing sizes that are available in each of the three systems: inch size, thin wall conduit, and metric size. Use this chart to help you choose tubing from the sizes available in your country.

## SUITABLE SIZES OF THINWALL TUBING

..... INCH SIZES ...			.THIN WALL CONDUIT..			.... METRIC SIZES ...																													
OUTSIDE DIAMETER	WALL THICKNESS	INSIDE DIAMETER	OUTSIDE DIAMETER	WALL THICKNESS	INSIDE DIAMETER	OUTSIDE DIAMETER	WALL THICKNESS	INSIDE DIAMETER																											
<table style="width: 100%; border-collapse: collapse;"> <tr> <td style="width: 33%;"><b>3/4 inch</b> (0.750") (19.1 mm)</td> <td style="width: 33%;"><b>18 gauge</b> (.043") (1.14 mm)</td> <td style="width: 33%;"><b>0.652"</b> (16.6 mm)</td> </tr> <tr> <td><b>3/4 inch</b> (0.750") (19.1 mm)</td> <td><b>16 gauge</b> (.065") (1.65 mm)</td> <td><b>0.620"</b> (15.7 mm)</td> </tr> </table>			<b>3/4 inch</b> (0.750") (19.1 mm)	<b>18 gauge</b> (.043") (1.14 mm)	<b>0.652"</b> (16.6 mm)	<b>3/4 inch</b> (0.750") (19.1 mm)	<b>16 gauge</b> (.065") (1.65 mm)	<b>0.620"</b> (15.7 mm)	<table style="width: 100%; border-collapse: collapse;"> <tr> <td style="width: 33%;"><b>*1/2 inch*</b> (0.710") (18.0 mm)</td> <td style="width: 33%;"><b>18 gauge</b> (.049") (1.24 mm)</td> <td style="width: 33%;"><b>0.612"</b> (15.5 mm)</td> </tr> </table> <p style="text-align: center; margin-top: 10px;"><b>Handrims, Footrests, and Fender Tubing</b></p>			<b>*1/2 inch*</b> (0.710") (18.0 mm)	<b>18 gauge</b> (.049") (1.24 mm)	<b>0.612"</b> (15.5 mm)	<table style="width: 100%; border-collapse: collapse;"> <tr> <td style="width: 33%;"><b>18 mm</b> (0.710")</td> <td style="width: 33%;"><b>1.00 mm</b> (.039")</td> <td style="width: 33%;"><b>16 mm</b> (.630")</td> </tr> <tr> <td></td> <td><b>1.20 mm</b> (.045")</td> <td><b>15.6 mm</b> (.614")</td> </tr> <tr> <td></td> <td><b>1.50 mm</b> (.059")</td> <td><b>15 mm</b> (.591")</td> </tr> <tr> <td><b>20 mm</b> (0.787")</td> <td><b>1.00 mm</b> (.039")</td> <td><b>18 mm</b> (.709")</td> </tr> <tr> <td></td> <td><b>1.20 mm</b> (.045")</td> <td><b>17.6 mm</b> (.693")</td> </tr> <tr> <td></td> <td><b>1.50 mm</b> (.059")</td> <td><b>17 mm</b> (.670")</td> </tr> </table>			<b>18 mm</b> (0.710")	<b>1.00 mm</b> (.039")	<b>16 mm</b> (.630")		<b>1.20 mm</b> (.045")	<b>15.6 mm</b> (.614")		<b>1.50 mm</b> (.059")	<b>15 mm</b> (.591")	<b>20 mm</b> (0.787")	<b>1.00 mm</b> (.039")	<b>18 mm</b> (.709")		<b>1.20 mm</b> (.045")	<b>17.6 mm</b> (.693")		<b>1.50 mm</b> (.059")	<b>17 mm</b> (.670")
<b>3/4 inch</b> (0.750") (19.1 mm)	<b>18 gauge</b> (.043") (1.14 mm)	<b>0.652"</b> (16.6 mm)																																	
<b>3/4 inch</b> (0.750") (19.1 mm)	<b>16 gauge</b> (.065") (1.65 mm)	<b>0.620"</b> (15.7 mm)																																	
<b>*1/2 inch*</b> (0.710") (18.0 mm)	<b>18 gauge</b> (.049") (1.24 mm)	<b>0.612"</b> (15.5 mm)																																	
<b>18 mm</b> (0.710")	<b>1.00 mm</b> (.039")	<b>16 mm</b> (.630")																																	
	<b>1.20 mm</b> (.045")	<b>15.6 mm</b> (.614")																																	
	<b>1.50 mm</b> (.059")	<b>15 mm</b> (.591")																																	
<b>20 mm</b> (0.787")	<b>1.00 mm</b> (.039")	<b>18 mm</b> (.709")																																	
	<b>1.20 mm</b> (.045")	<b>17.6 mm</b> (.693")																																	
	<b>1.50 mm</b> (.059")	<b>17 mm</b> (.670")																																	
<table style="width: 100%; border-collapse: collapse;"> <tr> <td style="width: 33%;"><b>7/8 inch</b> (0.875") (22.2 mm)</td> <td style="width: 33%;"><b>18 gauge</b> (.049") (1.24 mm)</td> <td style="width: 33%;"><b>0.777"</b> (19.7 mm)</td> </tr> <tr> <td><b>7/8 inch</b> (0.875") (22.2 mm)</td> <td><b>16 gauge</b> (.065") (1.65 mm)</td> <td><b>0.745"</b> (18.0 mm)</td> </tr> </table>			<b>7/8 inch</b> (0.875") (22.2 mm)	<b>18 gauge</b> (.049") (1.24 mm)	<b>0.777"</b> (19.7 mm)	<b>7/8 inch</b> (0.875") (22.2 mm)	<b>16 gauge</b> (.065") (1.65 mm)	<b>0.745"</b> (18.0 mm)	<table style="width: 100%; border-collapse: collapse;"> <tr> <td style="width: 33%;"><b>*3/4 inch*</b> (0.925") (23.5 mm)</td> <td style="width: 33%;"><b>17 gauge</b> (.055") (1.40 mm)</td> <td style="width: 33%;"><b>0.815"</b> (20.7 mm)</td> </tr> </table> <p style="text-align: center; margin-top: 10px;"><b>Sideframe Tubing</b></p>			<b>*3/4 inch*</b> (0.925") (23.5 mm)	<b>17 gauge</b> (.055") (1.40 mm)	<b>0.815"</b> (20.7 mm)	<table style="width: 100%; border-collapse: collapse;"> <tr> <td style="width: 33%;"><b>22 mm</b> (0.867")</td> <td style="width: 33%;"><b>1.00 mm</b> (.039")</td> <td style="width: 33%;"><b>20 mm</b> (.788")</td> </tr> <tr> <td></td> <td><b>1.20 mm</b> (.045")</td> <td><b>19.6 mm</b> (.772")</td> </tr> <tr> <td></td> <td><b>1.50 mm</b> (.059")</td> <td><b>19 mm</b> (.749")</td> </tr> <tr> <td><b>25 mm</b> (0.985")</td> <td><b>1.00 mm</b> (.039")</td> <td><b>23 mm</b> (.906")</td> </tr> <tr> <td></td> <td><b>1.20 mm</b> (.045")</td> <td><b>22.6 mm</b> (.892")</td> </tr> </table>			<b>22 mm</b> (0.867")	<b>1.00 mm</b> (.039")	<b>20 mm</b> (.788")		<b>1.20 mm</b> (.045")	<b>19.6 mm</b> (.772")		<b>1.50 mm</b> (.059")	<b>19 mm</b> (.749")	<b>25 mm</b> (0.985")	<b>1.00 mm</b> (.039")	<b>23 mm</b> (.906")		<b>1.20 mm</b> (.045")	<b>22.6 mm</b> (.892")			
<b>7/8 inch</b> (0.875") (22.2 mm)	<b>18 gauge</b> (.049") (1.24 mm)	<b>0.777"</b> (19.7 mm)																																	
<b>7/8 inch</b> (0.875") (22.2 mm)	<b>16 gauge</b> (.065") (1.65 mm)	<b>0.745"</b> (18.0 mm)																																	
<b>*3/4 inch*</b> (0.925") (23.5 mm)	<b>17 gauge</b> (.055") (1.40 mm)	<b>0.815"</b> (20.7 mm)																																	
<b>22 mm</b> (0.867")	<b>1.00 mm</b> (.039")	<b>20 mm</b> (.788")																																	
	<b>1.20 mm</b> (.045")	<b>19.6 mm</b> (.772")																																	
	<b>1.50 mm</b> (.059")	<b>19 mm</b> (.749")																																	
<b>25 mm</b> (0.985")	<b>1.00 mm</b> (.039")	<b>23 mm</b> (.906")																																	
	<b>1.20 mm</b> (.045")	<b>22.6 mm</b> (.892")																																	
<table style="width: 100%; border-collapse: collapse;"> <tr> <td style="width: 33%;"><b>1 inch</b> (1.000") (25.4 mm)</td> <td style="width: 33%;"><b>18 gauge</b> (.049") (1.24 mm)</td> <td style="width: 33%;"><b>0.902"</b> (22.9 mm)</td> </tr> </table>			<b>1 inch</b> (1.000") (25.4 mm)	<b>18 gauge</b> (.049") (1.24 mm)	<b>0.902"</b> (22.9 mm)	<table style="width: 100%; border-collapse: collapse;"> <tr> <td style="width: 33%;"><b>*1 inch*</b> (1.140") (29.5 mm)</td> <td style="width: 33%;"><b>17 gauge</b> (.055") (1.40 mm)</td> <td style="width: 33%;"><b>1.050"</b> (26.7 mm)</td> </tr> </table> <p style="text-align: center; margin-top: 10px;"><b>Seat Tubing, Bottom of X-Brace and Top of Footrest</b></p>			<b>*1 inch*</b> (1.140") (29.5 mm)	<b>17 gauge</b> (.055") (1.40 mm)	<b>1.050"</b> (26.7 mm)	<table style="width: 100%; border-collapse: collapse;"> <tr> <td style="width: 33%;"><b>25 mm</b> (0.985")</td> <td style="width: 33%;"><b>1.50 mm</b> (.059")</td> <td style="width: 33%;"><b>22 mm</b> (.867")</td> </tr> </table>			<b>25 mm</b> (0.985")	<b>1.50 mm</b> (.059")	<b>22 mm</b> (.867")																		
<b>1 inch</b> (1.000") (25.4 mm)	<b>18 gauge</b> (.049") (1.24 mm)	<b>0.902"</b> (22.9 mm)																																	
<b>*1 inch*</b> (1.140") (29.5 mm)	<b>17 gauge</b> (.055") (1.40 mm)	<b>1.050"</b> (26.7 mm)																																	
<b>25 mm</b> (0.985")	<b>1.50 mm</b> (.059")	<b>22 mm</b> (.867")																																	
<table style="width: 100%; border-collapse: collapse;"> <tr> <td style="width: 33%;"><b>1 inch</b> (1.000") (25.4 mm)</td> <td style="width: 33%;"><b>16 gauge</b> (.065") (1.65 mm)</td> <td style="width: 33%;"><b>0.870"</b> (22.1 mm)</td> </tr> </table>			<b>1 inch</b> (1.000") (25.4 mm)	<b>16 gauge</b> (.065") (1.65 mm)	<b>0.870"</b> (22.1 mm)	<table style="width: 100%; border-collapse: collapse;"> <tr> <td style="width: 33%;"><b>1 1/8 inch</b> (1.125") (28.6 mm)</td> <td style="width: 33%;"><b>18 gauge</b> (.049") (1.24 mm)</td> <td style="width: 33%;"><b>1.027"</b> (26.1 mm)</td> </tr> <tr> <td><b>1 1/8 inch</b> (1.125") (28.6 mm)</td> <td><b>16 gauge</b> (.065") (1.65 mm)</td> <td><b>0.995"</b> (25.3 mm)</td> </tr> </table>			<b>1 1/8 inch</b> (1.125") (28.6 mm)	<b>18 gauge</b> (.049") (1.24 mm)	<b>1.027"</b> (26.1 mm)	<b>1 1/8 inch</b> (1.125") (28.6 mm)	<b>16 gauge</b> (.065") (1.65 mm)	<b>0.995"</b> (25.3 mm)	<table style="width: 100%; border-collapse: collapse;"> <tr> <td style="width: 33%;"><b>25 mm</b> (1.181")</td> <td style="width: 33%;"><b>1.00 mm</b> (.039")</td> <td style="width: 33%;"><b>28 mm</b> (1.102")</td> </tr> <tr> <td></td> <td><b>1.20 mm</b> (.045")</td> <td><b>27.6 mm</b> (1.087")</td> </tr> <tr> <td></td> <td><b>1.50 mm</b> (.059")</td> <td><b>27 mm</b> (1.063")</td> </tr> </table>			<b>25 mm</b> (1.181")	<b>1.00 mm</b> (.039")	<b>28 mm</b> (1.102")		<b>1.20 mm</b> (.045")	<b>27.6 mm</b> (1.087")		<b>1.50 mm</b> (.059")	<b>27 mm</b> (1.063")									
<b>1 inch</b> (1.000") (25.4 mm)	<b>16 gauge</b> (.065") (1.65 mm)	<b>0.870"</b> (22.1 mm)																																	
<b>1 1/8 inch</b> (1.125") (28.6 mm)	<b>18 gauge</b> (.049") (1.24 mm)	<b>1.027"</b> (26.1 mm)																																	
<b>1 1/8 inch</b> (1.125") (28.6 mm)	<b>16 gauge</b> (.065") (1.65 mm)	<b>0.995"</b> (25.3 mm)																																	
<b>25 mm</b> (1.181")	<b>1.00 mm</b> (.039")	<b>28 mm</b> (1.102")																																	
	<b>1.20 mm</b> (.045")	<b>27.6 mm</b> (1.087")																																	
	<b>1.50 mm</b> (.059")	<b>27 mm</b> (1.063")																																	
<table style="width: 100%; border-collapse: collapse;"> <tr> <td style="width: 33%;"><b>1 1/4 inch</b> (1.250") (31.8 mm)</td> <td style="width: 33%;"><b>16 gauge</b> (.065") (1.65 mm)</td> <td style="width: 33%;"><b>1.120"</b> (28.4 mm)</td> </tr> </table>			<b>1 1/4 inch</b> (1.250") (31.8 mm)	<b>16 gauge</b> (.065") (1.65 mm)	<b>1.120"</b> (28.4 mm)	<table style="width: 100%; border-collapse: collapse;"> <tr> <td style="width: 33%;"><b>1 3/8 inch</b> (1.375") (34.9 mm)</td> <td style="width: 33%;"><b>16 gauge</b> (.065") (1.65 mm)</td> <td style="width: 33%;"><b>1.245"</b> (31.6 mm)</td> </tr> </table>			<b>1 3/8 inch</b> (1.375") (34.9 mm)	<b>16 gauge</b> (.065") (1.65 mm)	<b>1.245"</b> (31.6 mm)	<table style="width: 100%; border-collapse: collapse;"> <tr> <td style="width: 33%;"><b>30 mm</b> (1.181")</td> <td style="width: 33%;"><b>1.00 mm</b> (.039")</td> <td style="width: 33%;"><b>28 mm</b> (1.102")</td> </tr> <tr> <td></td> <td><b>1.20 mm</b> (.045")</td> <td><b>27.6 mm</b> (1.087")</td> </tr> <tr> <td></td> <td><b>1.50 mm</b> (.059")</td> <td><b>27 mm</b> (1.063")</td> </tr> </table>			<b>30 mm</b> (1.181")	<b>1.00 mm</b> (.039")	<b>28 mm</b> (1.102")		<b>1.20 mm</b> (.045")	<b>27.6 mm</b> (1.087")		<b>1.50 mm</b> (.059")	<b>27 mm</b> (1.063")												
<b>1 1/4 inch</b> (1.250") (31.8 mm)	<b>16 gauge</b> (.065") (1.65 mm)	<b>1.120"</b> (28.4 mm)																																	
<b>1 3/8 inch</b> (1.375") (34.9 mm)	<b>16 gauge</b> (.065") (1.65 mm)	<b>1.245"</b> (31.6 mm)																																	
<b>30 mm</b> (1.181")	<b>1.00 mm</b> (.039")	<b>28 mm</b> (1.102")																																	
	<b>1.20 mm</b> (.045")	<b>27.6 mm</b> (1.087")																																	
	<b>1.50 mm</b> (.059")	<b>27 mm</b> (1.063")																																	
<table style="width: 100%; border-collapse: collapse;"> <tr> <td style="width: 33%;"><b>1 1/2 inch</b> (1.5 ") (38.1 mm)</td> <td style="width: 33%;"><b>16 gauge</b> (.065") (1.65 mm)</td> <td style="width: 33%;"><b>1.375"</b> (34.9 mm)</td> </tr> </table>			<b>1 1/2 inch</b> (1.5 ") (38.1 mm)	<b>16 gauge</b> (.065") (1.65 mm)	<b>1.375"</b> (34.9 mm)	<table style="width: 100%; border-collapse: collapse;"> <tr> <td style="width: 33%;"><b>*1 1/4 in.*</b> (1.5 ") (38.1 mm)</td> <td style="width: 33%;"><b>16 gauge</b> (.065") (1.65 mm)</td> <td style="width: 33%;"><b>1.375"</b> (34.9 mm)</td> </tr> </table> <p style="text-align: center; margin-top: 10px;"><b>Hub Tubing Sizes</b></p>			<b>*1 1/4 in.*</b> (1.5 ") (38.1 mm)	<b>16 gauge</b> (.065") (1.65 mm)	<b>1.375"</b> (34.9 mm)	<table style="width: 100%; border-collapse: collapse;"> <tr> <td style="width: 33%;"><b>35 mm</b> (1.379")</td> <td style="width: 33%;"><b>1.00 mm</b> (.039")</td> <td style="width: 33%;"><b>33 mm</b> (1.300")</td> </tr> <tr> <td></td> <td><b>1.20 mm</b> (.045")</td> <td><b>32.6 mm</b> (1.283")</td> </tr> <tr> <td></td> <td><b>1.50 mm</b> (.059")</td> <td><b>32 mm</b> (1.261")</td> </tr> <tr> <td><b>40 mm</b> (1.575")</td> <td><b>1.50 mm</b> (.059")</td> <td><b>37 mm</b> (1.458")</td> </tr> </table>			<b>35 mm</b> (1.379")	<b>1.00 mm</b> (.039")	<b>33 mm</b> (1.300")		<b>1.20 mm</b> (.045")	<b>32.6 mm</b> (1.283")		<b>1.50 mm</b> (.059")	<b>32 mm</b> (1.261")	<b>40 mm</b> (1.575")	<b>1.50 mm</b> (.059")	<b>37 mm</b> (1.458")									
<b>1 1/2 inch</b> (1.5 ") (38.1 mm)	<b>16 gauge</b> (.065") (1.65 mm)	<b>1.375"</b> (34.9 mm)																																	
<b>*1 1/4 in.*</b> (1.5 ") (38.1 mm)	<b>16 gauge</b> (.065") (1.65 mm)	<b>1.375"</b> (34.9 mm)																																	
<b>35 mm</b> (1.379")	<b>1.00 mm</b> (.039")	<b>33 mm</b> (1.300")																																	
	<b>1.20 mm</b> (.045")	<b>32.6 mm</b> (1.283")																																	
	<b>1.50 mm</b> (.059")	<b>32 mm</b> (1.261")																																	
<b>40 mm</b> (1.575")	<b>1.50 mm</b> (.059")	<b>37 mm</b> (1.458")																																	

# TUBING AND BENDING DIE SIZE

Different sizes of tubing require different size dies. Each different tubing size will also require a die set with a specific bending radius. The Hossfeld dies are listed according to their Center Line Radius (C.L.R.) The Center Line Radius is the distance between the center of the circle and the center of the tubing as it is bent (see diagram). Before ordering die sets from Hossfeld, consult with the following charts and choose die sets that are compatible with the tubing you are using for sideframes and footrests.

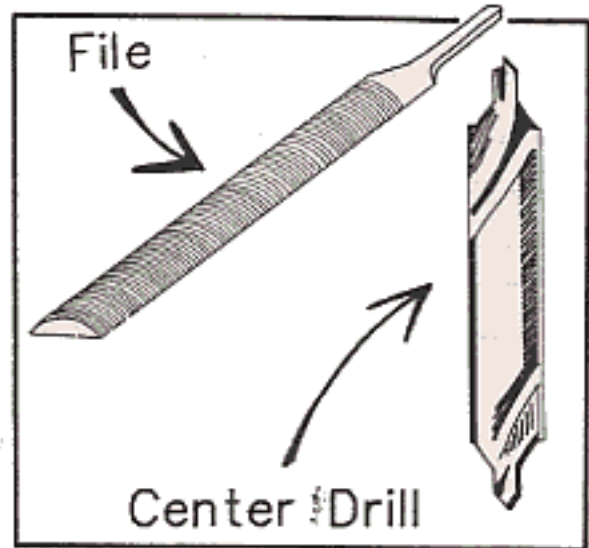

## DIE SIZES FOR SIDEFAME TUBING

As a general rule, when bending the sideframe tubing, use the bending die set with the smallest Center Line Radius (bending radius) that will not wrinkle your tubing. We have found that Hossfeld bending dies with the following Center Line Radii will usually bend 18 gauge mild steel tubing (0.049" or 1.2 mm wall thickness). Note that our minimum recommended Center Line Radii are smaller than those recommended by Hossfeld for thinwall tubing; nevertheless we have used these dies with few problems. Other types of benders may have different minimum bending radii. Some types of tubing, especially tubing made of harder steel or tubing with a thinner wall such as 20 gauge (0.035" or 1 mm wall thickness) tubing will require die sets with larger Center Line Radii.

SIDEFAME TUBING	HOSSFELD DIE SIZE	MINIMUM CENTER LINE RADIUS
7/8"	7/8"	2"
1"	1"	2-1/2"
3/4" Thin Wall Conduit	3/4" Conduit	3" or smaller
22 mm	7/8"	2"
25 mm	1"	2-1/2"

## BENDING DIES FOR FOOTREST TUBING

The size of the Center Line Radius will influence the size of the footrest - the larger the



radius the larger the footrest. Some people prefer larger footrests to support their feet, others prefer smaller footrests that take up less room.

FOOTREST TUBING	DIE SIZE	BENDING RADIUS
3/4"	3/4"	1-7/8"
1/2" Thin Wall Conduit	1/2" Thin Wall Conduit	1-1/4" or 2"
18mm	1/2" Thin Wall Conduit	1-1/4" or 2"

## SUPPLIES

In addition to the materials and parts that go into each wheelchair, basic supplies will be used up as you manufacture chairs. Each chair uses about a pound of bronze, a couple of sanding cloths, and one or more high quality hacksaw blades. You will also be using files that get dull and drill bits that can break. The following list of supplies will get you started. Count on purchasing more supplies before you begin serious production. If you purchase your supplies in relatively large quantities you should be able to negotiate a lower price.

SUPPLIES	Quantity	\$/Unit	Total \$
Bronze, kilograms	10	5.50	55.00
Center Drills	4	4.00	16.00
Files, 14 inch round	10	9.00	90.00
Files, 8 inch 1/2 round	10	6.00	60.00
Flux, cans	2	4.00	8.00
Glue, wood	1	3.00	3.00
Hack Saw Blades	60	0.60	36.00
High Speed Drill bits, 29 piece set	2	45.00	90.00
Oil, cutting, litres	4	2.00	8.00
Oil, lubricating, litres	2	2.00	4.00
Paint, quarts or spray cans	4	4.00	16.00
Paint thinner, liter	4	0.50	2.00
Primer, quarts or spray cans	4	4.00	16.00
Rags, cloth	10	0.00	0.00
Sanding Cloth	20	0.70	14.00
<b>SUPPLIES TOTAL</b>			<b>\$418.00</b>



# WELDING ROD

While steel welding rod is far less expensive than bronze, we use bronze brazing rod with flux because it produces a stronger weld on thin walled tubing. The strength of a weld made with steel welding rod on thin walled steel tubing is not very predictable. We recommend that you use steel welding rod only on the handrims where the stress is less than it is on the frame of the chair.

Don't worry that the bright yellow bronze welds will make the chair less attractive. The bronze welds will be covered when the chair is painted.

# TO PAINT OR TO PLATE

It is important to protect the chair from rust. In some climates rust is a much more serious problem than in others. A chair in these climates may fall apart in a year or two if it is not well painted or plated. Painting or plating can also help to sell a chair. The easiest chair to sell is one that looks good - and in the past that has been a chrome plated hospital-type chair. Unfortunately, that is also the most expensive chair. Recently brightly colored sports chairs have also become very popular, especially among young and active riders.

One of the most effective ways of preventing rust is to galvanize (zinc plate) the thinwall tubing. Zinc plating is less expensive than nickel or chrome, though more expensive than paint. It is most effective when applied after the chair frame is welded together, and is usually done by an outside supplier. Pre-galvanized tubing can also be used, but not without special precautions. Galvanized tubing gives off poisonous fumes when it is heated for welding. If it is used at all, it must be welded outdoors, positioned so that none of the fumes are inhaled.

Paint of any color can be used over plain or galvanized tubing. Paints and primers vary widely in how well they stick to the chair and how easily they can be scratched. Epoxy base primers stick to the chair the best. If they are not available, use an oil base primer, or a special primer for galvanized tubing. In either case the metal should be thoroughly sanded and then prepared with an acid etching solution to make sure the primer sticks to the metal.

Polyurethane base paints are more difficult to scatch than most. If they are not available, test and compare some of the paints that are available locally. Use any creative method to mutilate a paint job that you can come up with (scratch it with a pocket knife, bang it on the table, and so forth) to see which paint is best.

Nickel or chrome plating can add from \$20 to \$30 to the cost of the chair. Chrome often pits and peels unless a copper underplating is added, at additional cost. Since painting the chair is much less expensive, we recommend priming and painting the frame and only plating the footrests, brakes, and fenders.

[Table of Contents](#)

# Center for International Rehabilitation

## Chapter 6 Metalworking Techniques

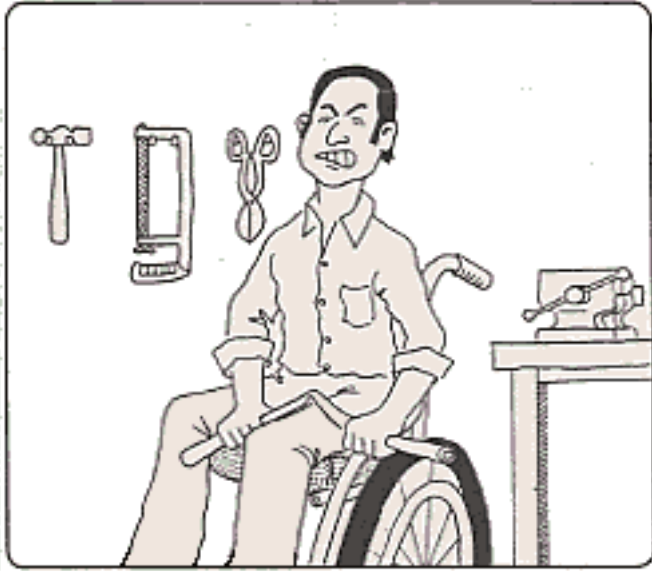

To build a wheelchair, tubing, bar, and rod must be cut, bent, drilled, and brazed. Occasionally, the tubing will need to be enlarged or reduced to enable one piece to fit over another. Many pieces must be bolted together using locknuts. Rather than stopping in the middle of the building instructions in each chapter to explain these procedures, we have chosen to devote this chapter to describing all the basic techniques involved in building the wheelchair.

Before trying to build a chair, take some time to practice the basic techniques described in this chapter. It will save you a lot of time and frustration in the long run. This chapter includes descriptions of how to bend tubing, steel bar, and rod, how to measure the bends accurately, how to make tubing larger or smaller, how to drill holes accurately, and how to make your own locknuts. This manual is not designed to teach you how to weld. Welding is a skill that should be taught first hand. We would, nevertheless, like to remind you to follow

simple safety procedures: wear welding goggles, leather gloves and shoes, and a leather apron. Damage to your eyes, red hot brass in your lap, and burned fingers are all injuries that can be prevented.

### THE HOSSFELD STYLE BENDER

The Hossfeld Style bender is made up of a bending frame, bending dies, and special parts that are used when bending bar or rod. (A description of how to make and assemble the bending frame is found in Appendix A at the end of the book). The photo and list on the next page should identify each part.

You may wish to refer back to this list when following the different directions for setting up the bender to bend tubing, bar, or rod.

- 1) Bending Frame
- 2) Die Set:
  - a) Draw Block
  - b) Form Die
  - c) Back Block
- 3) Auto Jack
- 4) Center Pin
- 5) U-Shaped Pin

- 6) U-Pin Roller
- 7) Eye Bolt Bending Dog
- 8) Flat Head Pin
- 9) Eye Pin
- 10) Thumb Nut
- 11) Caster Fork Bending Die
- 12) Center Pin Support Plate

## SETTING UP THE BENDER TO BEND TUBING

To set up the bender, you will need an already assembled frame, a "U" shaped pin, an eye pin, and a bending die set (back block, draw block, and form die). Be sure to store each bending die set together; they are not interchangeable.

Both the diameter of the tubing and the radius of the bend will affect the size of die set needed for each bend. The following directions will work for any size die set.

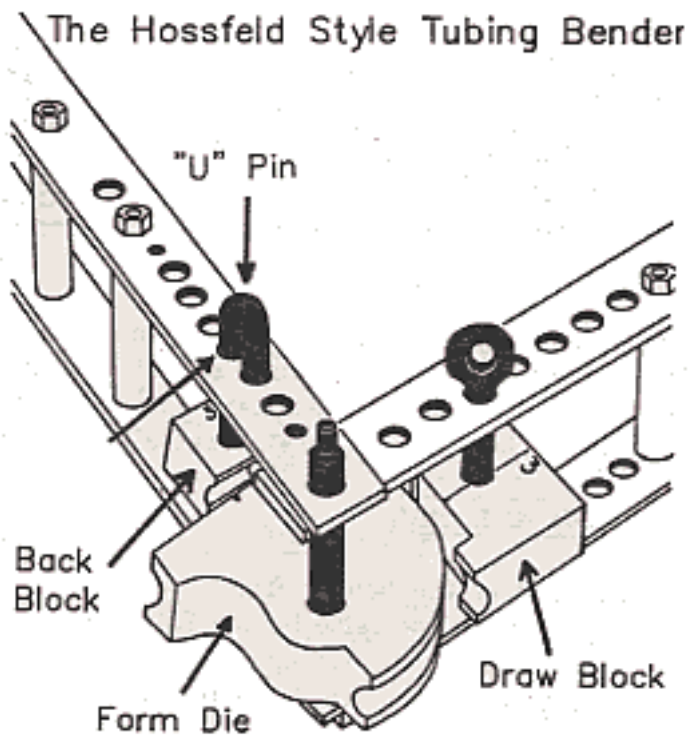

1) Mount the back block, with the numbered side on top, between the steel bars of the outer arm using the U-shaped pin as shown. The long shaft of the U-shaped pin should pass through the hole that corresponds to the number stamped on the back block.

2) Mount the draw block, with the numbered side up, between the steel bars of the inner arm. As with the back block, the number on the block corresponds to the number of the hole. Put a little wax or grease on the draw block. Be careful not to get any on the back block or form die.

3) Mount the form die at the pivot point using the center pin. As with the two blocks, the die is mounted with the numbering on top. The straight edge of the form die should be set parallel to the back block as shown.

## BENDING THE TUBING

Now that the bender is set up, you are ready to begin bending.

- 1) To insert the tubing, fold the bender back on itself as far as it will go. Adjust the channels in the back block and the draw block until they form a straight line.
- 2) Insert the tubing between the back block and form die. Line up the bending mark on the tubing with the bending mark on the form die. Tap the straight edge of the form die firmly against the tubing. If any space is left, the tubing may kink.
- 3) Clamp vise grips onto the tubing (as shown on the previous page) to prevent it from being drawn into the bender.
- 4) Using a "cheater pipe" for leverage, bend the tubing around the form die.
- 5) To bend large-diameter tubing, attach a ratchet-type auto jack to the bender frame and use it to pull the inner arm around the die. To attach the auto jack to the bender frame, drill a 1/2" hole in the auto jack. Bolt it to the frame using the last bolt in the stationary outer arm of the frame. Hook the other end of the jack to the last bolt in the moveable inner arm.

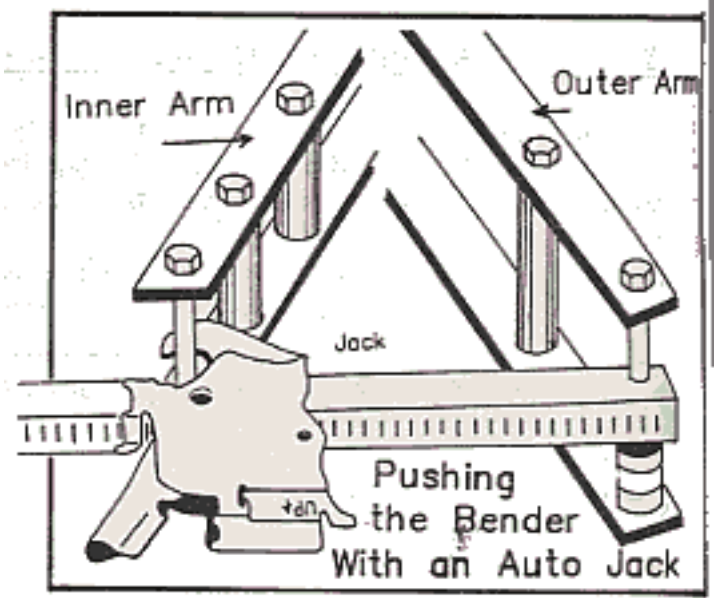
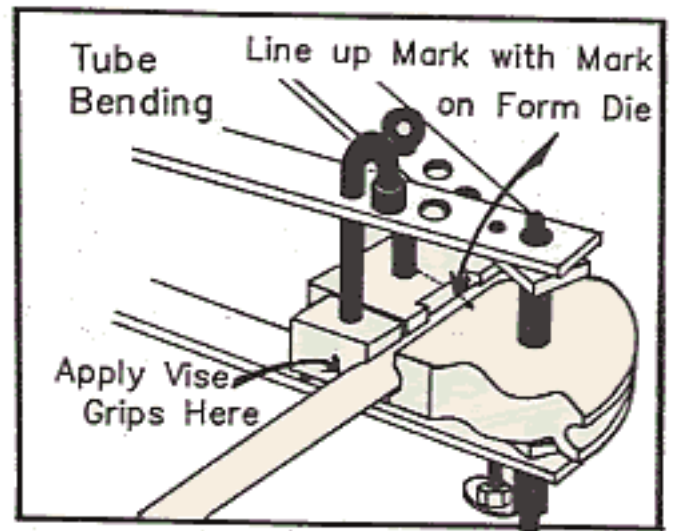

# SETTING UP THE BENDER TO BEND ROD AND BAR

Unlike tubing, which is bent between the arms of the bender frame, rod and bar are bent on top of the frame. To set up the bender use the same bender frame, U pin, and eye pin that you used to bend tubing. Instead of using the tubing die sets, use the eye bolt bending dog, the thumb nut, the flat head pin, and either the U-pin roller or the caster fork bending die.

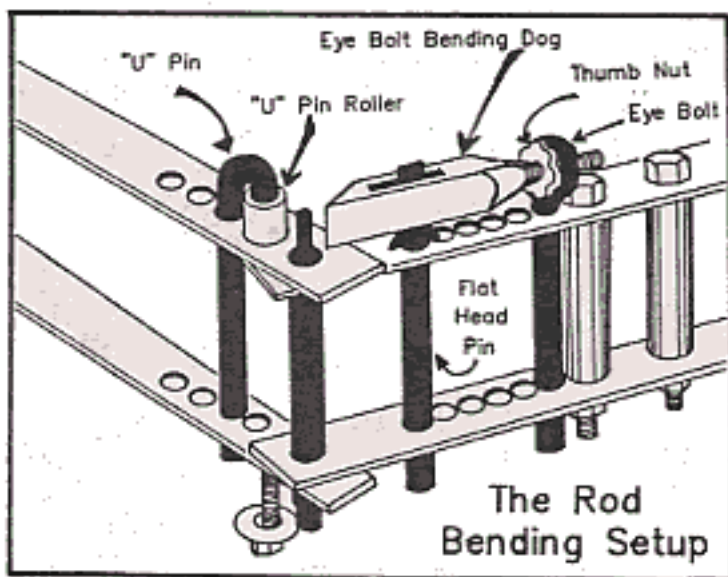

## BENDING ROD

The following set up will bend the brake out of 5/16" (8 mm) rod.

- 1) Insert the center pin so that the small end is on top.
- 2) Insert the main shaft of the U pin through the second set of 5/8" holes on the outer arm of the frame. Mount the U-pin roller on the short end of the U pin.
- 3) Insert the eye pin into the sixth set of holes in the inner arm of the frame.

4) Insert the flat head pin into the first set of holes in the inner arm of the frame.

5) The eye bolt bending dog is held in place by the flat head pin on one end and the eye bolt on the other. Screw the thumb nut onto the eye bolt bending dog. Slip the square hole in the eye bolt bending dog over the flat head pin and slip the threaded end into the eye bolt. Be sure that the indented side of the flathead pin faces the longer side of the bending dog.

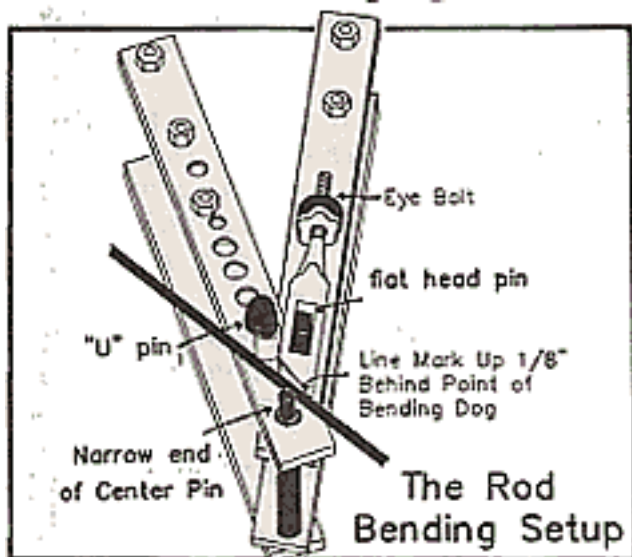

6) Fold the bender back on itself and insert the rod. Position the rod back about 1/8" (3 mm) from where the bend should begin. (The rod will be drawn slightly into the bender as it is bent.)

7) Tighten the thumb nut on the eye bolt bending dog to hold the rod tightly in place.

8) Pull the moveable inner arm of the bender around until the rod is bent to the angle desired.



# BENDING FLAT BAR STOCK

The front caster forks and the handrim brackets use bent flat bar. To bend the caster fork, use the same parts as for bending rod plus the caster fork bending die. The caster fork bending die can be purchased as part of the Basic Tool Kit or it can be made out of 2" waterpipe (actual 2 3/8" O.D.) and a 3/4" I.D. washer. Directions for making the caster fork bending die can be found in Appendix B.

- 1) Adjust the 7/16" bolt and center pin support plate (or washer) until the center pin sticks up approximately 1-1/2" (4 cm) on top.
- 2) Mount the U pin, with or without the U-pin roller, through the 2nd or 3rd holes in the outer arm of the frame.
- 3) Mount the flat head pin through the second set of holes on the inner arm of the frame. The indented side of the pin goes on top and faces the longer side of the eye bolt bending dog.
- 4) Mount the eye bolt through the last 5/8" hole on the inner arm of the frame.
- 5) Put the threaded end of the eye bolt bending dog through the eye bolt, and slip the square hole over the flat head pin.
- 6) Mount the caster fork bending die on top of the center pin.
- 7) Fold the bender back on itself and insert the flat bar. Line the bending mark on the bar up with the point of the bending dog.
- 8) Tighten the thumb nut on the eye bolt bending dog until it holds the bar firmly against the die. Pull on the moveable arm to bend the bar around the die.

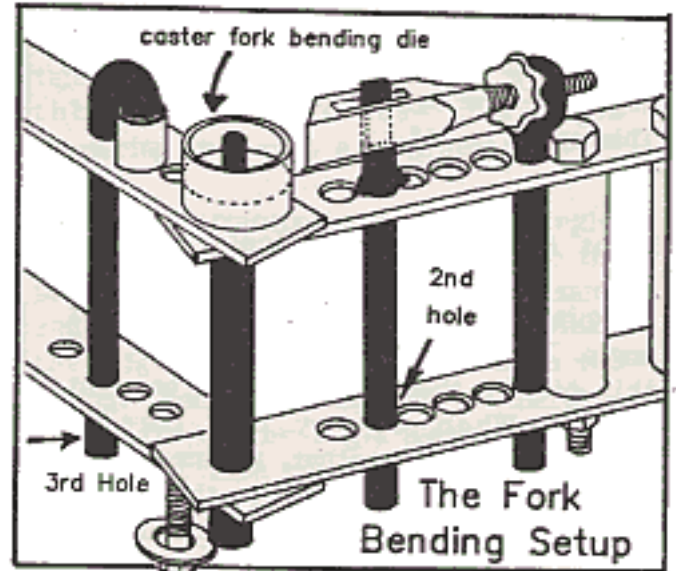

# MEASURING THE BEND

When bending tubing, steel bar, or rod, you will need to measure accurately how far it has been bent. The following section defines the terms we will use and describes techniques for measuring the bends.

## MEASURING TERMS

### Parallel

Two straight lines are parallel when the distance between them remains the same all along the lines.

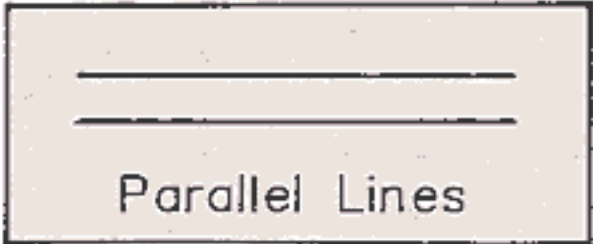

### Angle and Degrees

When two lines meet they form an angle. The size of an angle can be measured in degrees. The symbol for degrees is  $^{\circ}$ . This angle is  $45^{\circ}$ .

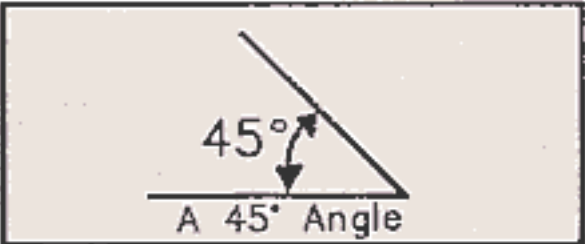

### Right Angle or Perpendicular

A square corner is also called a right angle. It measures  $90^{\circ}$  (90 degrees). In this picture there are two  $90^{\circ}$  or right angles. When we say one line is perpendicular to another, we mean that they form right angles where they meet. In the picture line B is perpendicular to line A.

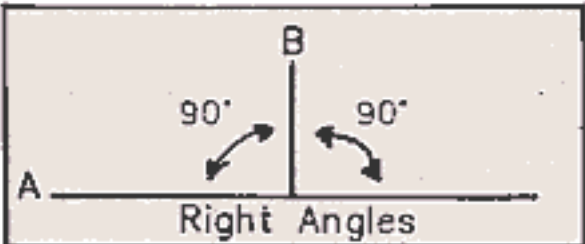

## HOW TO MEASURE AN ANGLE

To measure the size of an angle use a protractor. Line up the straight edge and the moveable arm of the protractor with the two lines that form the angle. The end of the arm of the protractor will point to the number of degrees on the scale. This number is the size of the angle.

Any angle can be measured in two ways, either from one side or from the other. For example, the angle of the bend in this footrest tube is 70~ or 110~ depending on which side it was measured from. After measuring the angle of a piece, hold that piece up to a similar piece to be sure they have the same angle.

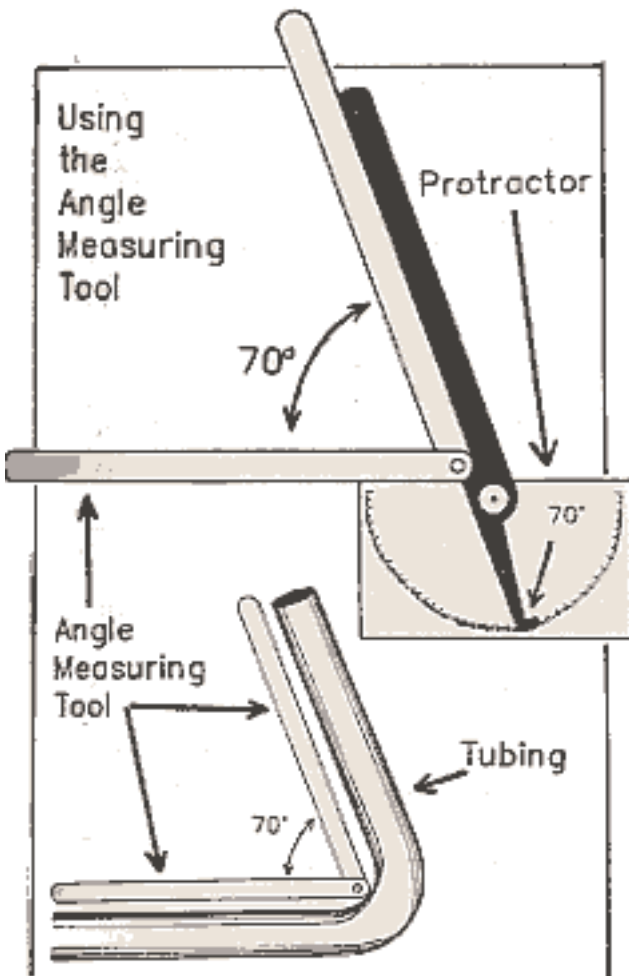
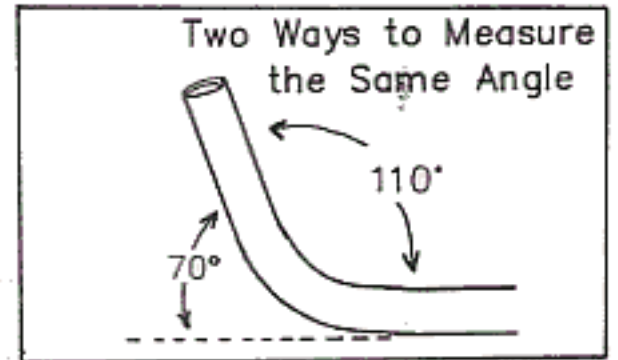
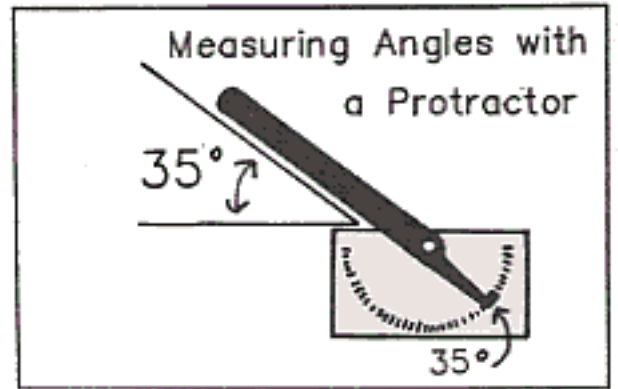

When measuring the angle of a piece of tubing you are bending, it is easier to use an angle measuring tool with longer arms rather than a protractor. You can make your own angle measuring tool out of two thin steel bars about 6" to 8" (15 to 20 cm) long, a bolt, and a nut. The nut should be loose enough so that you can open and close the steel bars and tight enough so that they will stay at the desired angle. Use this angle measuring tool with a protractor.

Set your protractor to the desired angle. Hold the angle-measuring tool up to the protractor and adjust it to the same angle. As you bend the tubing, place the angle measuring tool next to the tubing. Bend the tubing until it matches the angle of the angle measuring tool. A pre-bent tube can be used instead of the measuring tool.



# TECHNIQUES FOR REDUCING TUBING DIAMETER

The tubing of the X-brace and the footrest must fit snugly over the sideframe tubing. The following techniques can be used whenever it is necessary to slightly reduce the diameter of tubing.

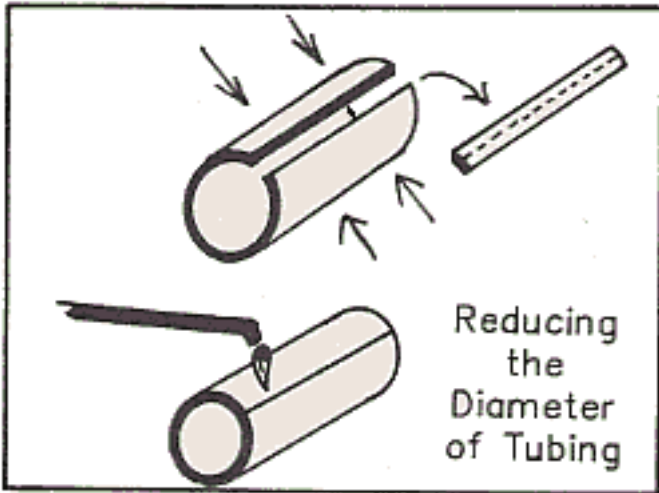

## CUT AND WELD

- 1) Cut a section out of the tubing. It is best to remove the section that includes the seam.
- 2) Squeeze the tube together.
- 3) Weld the new seam using a steel welding rod.

## INDENT THE TUBING

Another way to reduce a piece of tubing to fit snugly over the sideframe tubing is to make an indentation in the tube as close to each end as possible.

- 1) Use the tubing cutter with an indenting wheel instead of a blade. The indenting wheel will make an indentation about 1/4" (6 mm) wide. The indenting wheel can be purchased as part of the Basic Tool Kit (see Chapter 2).
- 2) Put a solid steel bar inside the tube you are going to reduce. The solid bar will prevent you from indenting the tube too far. The solid bar should be slightly smaller in diameter than the sideframe tubing.
- 3) Roll the tubing cutter around the tube as close to each end as possible. Continue rolling and tightening the tubing cutter until the tube fits snugly on the solid bar.
- 4) Remove the solid bar and test the tube on the sideframe tubing.

This method of indenting can also be used to tighten tubing around ball bearings (Chapter 11) or to make a good seat for ball bearings (Chapter 12).

# ENLARGING TUBING DIAMETER

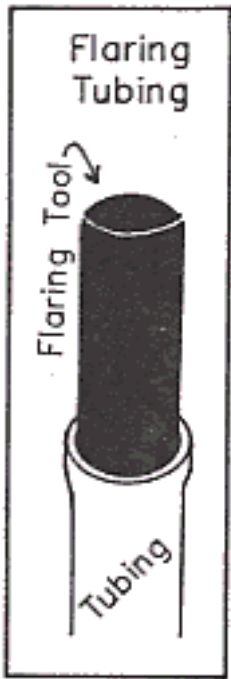

- 1) Slide the tubing over a piece of solid steel rod. This rod should fit fairly snugly inside the tubing. Lay the rod between two blocks of wood.
- 2) Hammer on the side of the tube, striking evenly from one end to the other, until the tube is stretched to the right size.

# FLARING THE ENDS OF TUBING

If only the end of the tube needs to be enlarged (to fit a ball bearing, for example) a flaring tool can be used. A flaring tool is a piece of solid rod which has been turned in a lathe to just the right size. If you need to flare the end more than a very small amount, several flaring tools of increasing size can be used.

# DRILLING ACCURATE HOLES

Whether you are making jigs or drilling holes directly in parts of the wheelchair, it is very important that your holes are drilled in exactly the right spot.

- 1) Scribe an X to mark the exact center of the hole.
- 2) Punch the center of the X with a center punch.
- 3) Drill the center of the X with a center drill. If you don't have a center drill, you can whack the center punch hard enough to leave an indentation that will hold a 1/8" (3 mm) drill bit. A short wide drill bit is more accurate than a long thin one because it is less flexible.

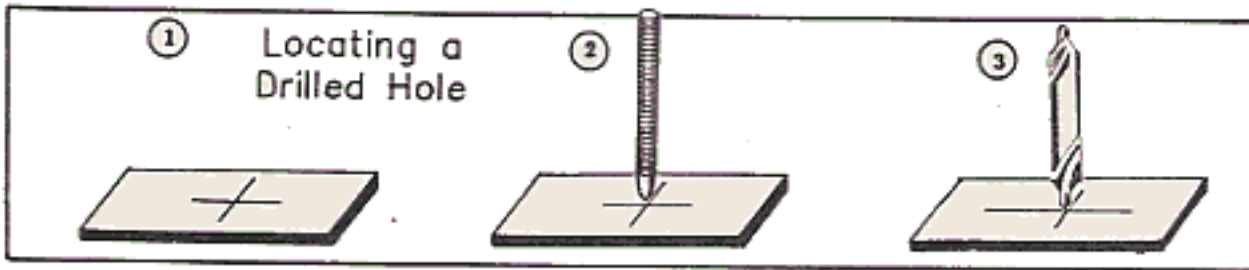

- 4) When drilling a hole larger than 5/16" (8 mm) start by drilling a smaller hole. The smaller hole should be less than half of the diameter of the big one.

# MAKING YOUR OWN LOCKNUTS

Nuts that don't loosen up easily are critical to a well-made wheelchair. The nuts on the axle bolts, the seat fabric bolts, the x-brace bolt, and the caster bolts should all be locked in place for the safety of the rider.

Lock washers placed under the nuts can help to keep them from loosening; however, there is so much vibration in a wheelchair, lock washers alone are often inadequate. A true locknut, one which will not spin freely even after it is loosened, is a better choice.

One type of commercial locknut that works well is a nylon lined locknut. Unfortunately, these nuts are expensive and are only available in some countries. If you are unable to purchase good quality locknuts in your area, a locknut can be made out of a standard, non-locking nut by bending the nut until it is difficult to put on or take off. The following method was developed by A.R.I.F.A. in Paraguay (Asociacion de Rehabilitacion del Impedido Fisico de Asuncion).

1) Screw a standard nut halfway onto the end of a bolt. Lay it on a vise or anvil and whack it with a heavy hammer.

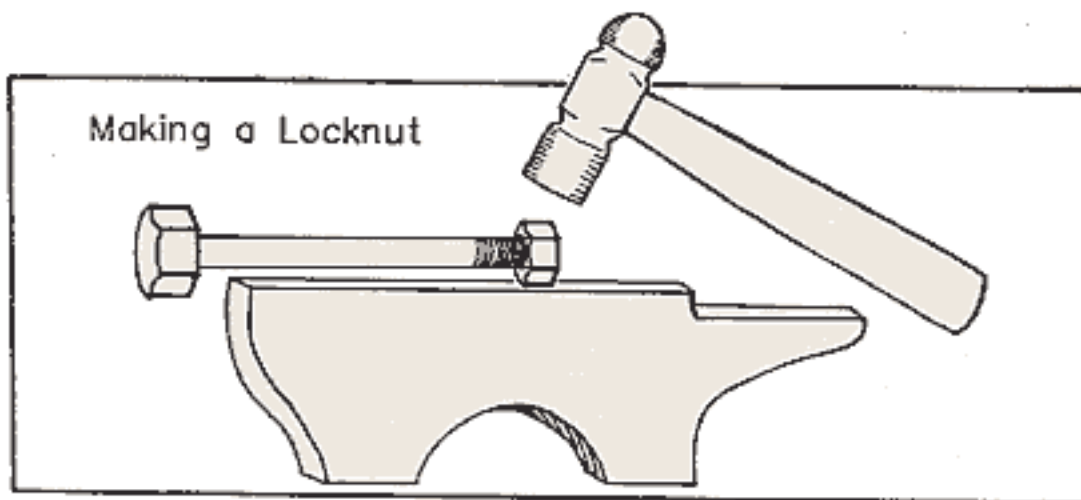

Once a locknut has been turned on the bolt several times, it will lose some of its locking strength. Customers should be warned of this fact. Whenever a chair is disassembled, any nuts that turn easily should be bent or punched until they are difficult to turn.

There are several types of fluids available that lock nuts. We do not recommend these fluids to build wheelchairs; once these nuts have been loosened, their locking strength is gone.

[Table of Contents](#)

# Center for International Rehabilitation

## Chapter 7 Bending the Sideframe

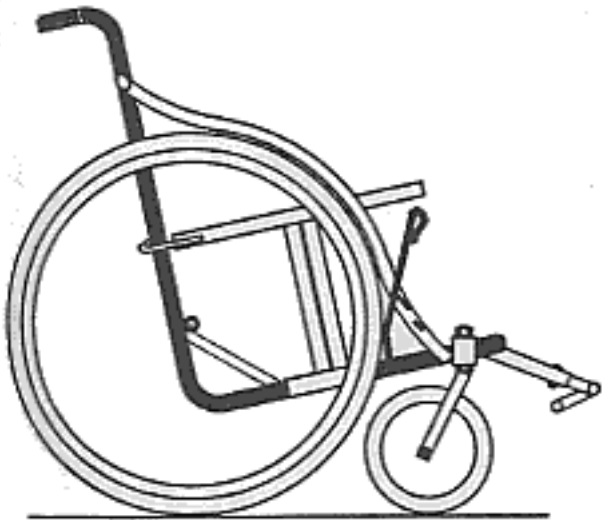

Now that your bender is assembled, and you have decided on the back height and frame length for this chair, you are ready to start bending. This chapter describes how to bend the main sideframe tubes, drill the holes that will be used to attach the seatback, and drill the brake mounting hole.

Once the first two bends are made in the sideframe pieces, they will be set aside. Only after the x-brace is made and slid onto the sideframe can the third bend be made in the frame.

We have chosen 7/8" O.D. tubing for the sideframe because it is the smallest (and therefore lightest) size that can withstand heavy use. In Paraguay, 7/8" tubing has not been available. They have made a particularly heavy-duty chair out of 1" tubing and have found that it works quite well. The larger tubing only adds about a pound to the chair.

## MATERIALS

ITEM	QUANTITY	PART OF CHAIR
* 7/8" O.D. Tubing	2 pieces, 5' (152 cm) long	sideframe
Bicycle handgrips or tubing	2 pieces, 3" (7.6 cm) long	handgrips
* 1" O.D. Tubing or 3/4" Thin Wall Conduit can also be used.		

**Note:** In our design the sideframe tubing must fit snugly inside the pieces of tubing which form the bottom of the x-brace and the top of the footrest. Before selecting sideframe tubing, be sure that you can buy or make tubing in a size that will fit snugly over it. See [Chapter 5](#) for tables on available sizes of tubing, and combinations of tubing sizes that will work.

## JIGS AND BENDERS

- Hossfeld-style tubing bender with Hossfeld dies

(Hossfeld dies and a Hossfeld-style bender frame can be purchased as a part of the Basic Tool

Kit. If you wish to make your own, instructions for making the bending frame can be found in [Appendix A.](#))

- Plywood Square
- Seat Back Drilling Jig
- Brake Hole Drilling Jig

(Instructions for making these jigs can be found in Appendix B. They can also be purchased as part of the Basic Tool Kit.)

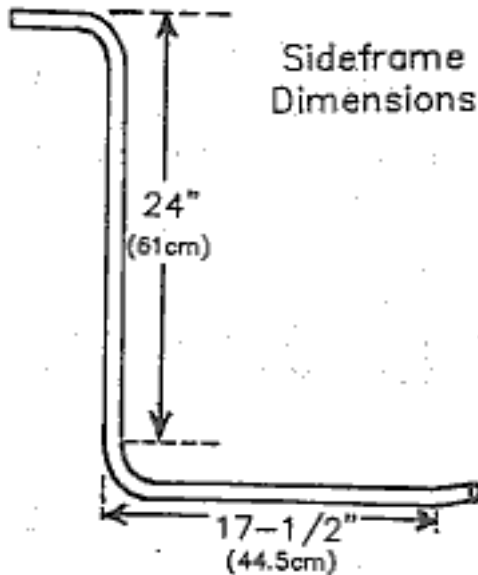

## DIRECTIONS

1) If you have not done so already, measure the customer and determine the height of the seat back and the length of the frame. (See Chapter 4 for information on how to design the chair to fit the customer.)

The following directions will be for a standard-size frame with a back height of 24" (61 cm) and a frame length of 17-1/2" (44.5 cm). Alter these measurements to make a larger or smaller chair.

2) Measure 3-1/2" (8.8 cm) and mark where to make the first bend in each 5' (152 cm) length of 7/8" tubing.

3) Set up the Hossfeld style bender to bend tubing using the die set for 7/8" O.D. tubing with a 2" bend radius. See Chapter 6 for a detailed description of how to bend tubing and how to set up the bender. Put some wax or grease on the draw block. Do not get any on the back block! If you are using one of the alternative sizes of tubing, check the chart in Chapter 5 for the appropriate die sizes.

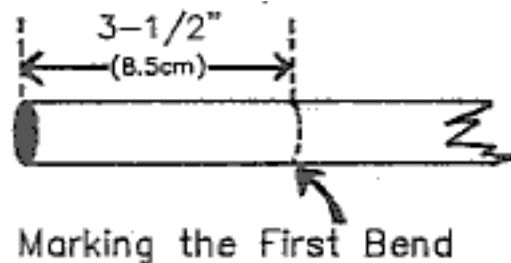

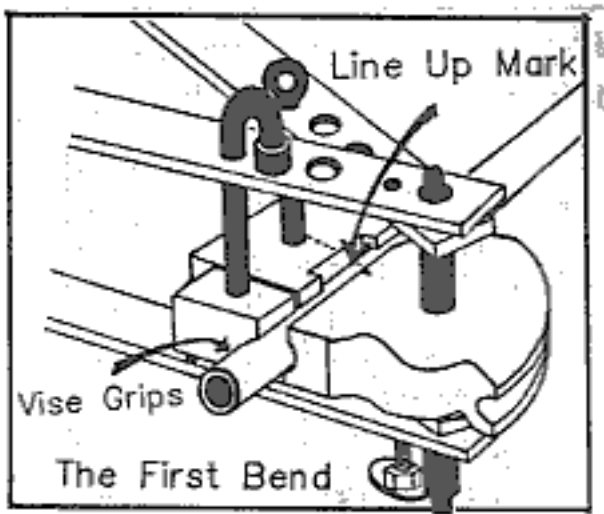

4) Align the mark on the tubing with the positioning mark on the form die. Clamp a pair of vise grips onto the tubing right next to the back block.

5) Bend the tubing  $90^\circ$ , forming a right angle. Use the plywood square to be sure the angle is exactly  $90^\circ$ . A description of how to make the plywood square is found in Appendix B.

6) Remove the sideframe tube from the bender. Holding a straightedge along the top of the bend, measure 24" (61 cm) down the tube and mark the beginning of the next bend.

7) Align this mark with the positioning mark on the form die and bend the tubing  $90^\circ$  in the opposite direction from the handle. Use the plywood square to be sure the bend is exactly  $90^\circ$ .

When making this second bend be sure that the top of the tubing in the first bend is level with the top of the form die. If the tubing is tilting even slightly, the second bend will point off at an odd angle. Laying a straight edge along the top of the form die can help you to accurately judge if the tubing is correctly aligned in the bender.

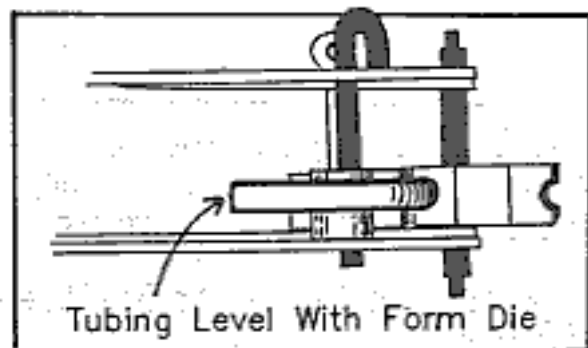
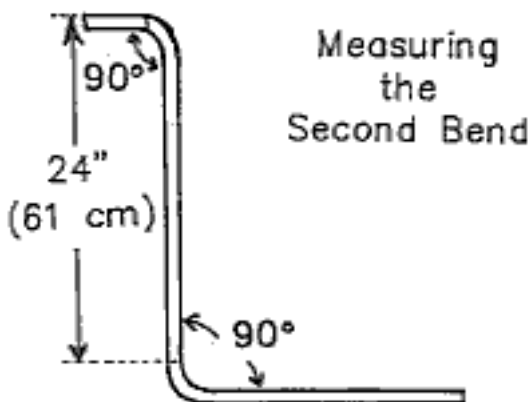



## Drilling the Sideframe

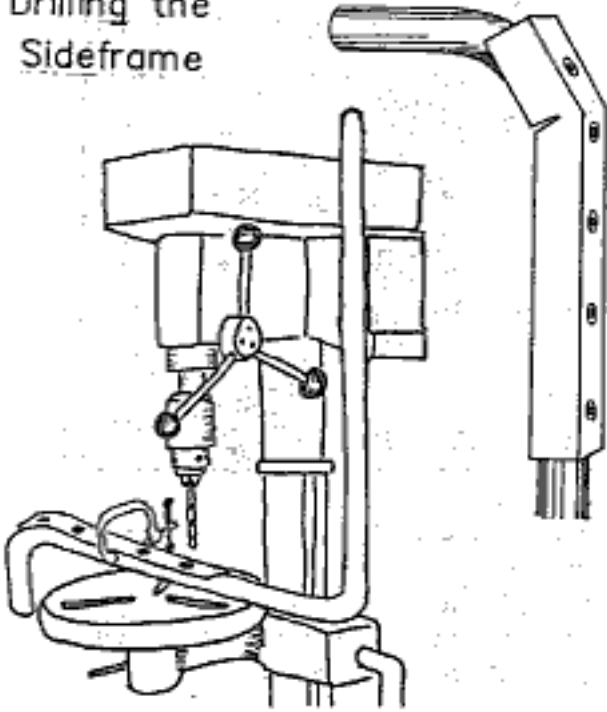

8) Place the seat back tube drilling jig onto the sideframe piece as shown.

9) Clamp it in place with the drill press vise. Sight along the long piece of frame tubing to be sure that the tubing is aligned correctly in the vise. The long piece of tubing should be parallel to the column of the drill press.

10) Drill the seat back holes. The hole size should be about  $\frac{3}{16}$ " (5mm) in diameter. Use the smallest size of hole that will accept a #12 sheet metal screw. When drilling the holes, only drill through one side of the tubing. Do not drill completely through to the other side. These holes will be used to attach the seat fabric to the frame.

11) Place a straightedge behind the second bend. Measure  $12\frac{3}{4}$ " (32.4 cm) down the tube and mark where the brake mounting hole will be drilled.

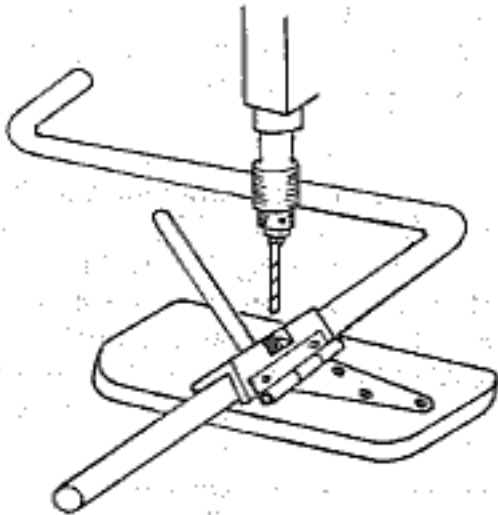

12) Place the brake hole drilling jig on the workbench. Make a level surface by adding pieces of  $\frac{3}{4}$ " (20mm) plywood on either side of the jig. Position the sideframe in the jig so that it lies flat on the table. At the mark for the brake, use the jig to drill a  $\frac{5}{16}$ " (8mm) hole all the way through the sideframe tube. Make sure that the drill is vertical. If the jig keeps the drill bit from pointing straight up and down, see Appendix B for instructions on how to adjust the jig to drill vertical holes.

13) Set these frame pieces aside until the x-brace has been made and slid onto the sideframe pieces. The third bend can only be made and the brake mounting welded in place after the x-brace pieces have been put onto the frame (Chapter 8).

IT IS IMPOSSIBLE TO PUT THE X-BRACE PIECES ON AFTER THE THIRD BEND HAS BEEN MADE.

# Center for International Rehabilitation

## Chapter 8 Bending the Fenders

Both the handrims and fenders use a wooden bender that has been designed to make bends with a large radius. While you won't need the finished handrims until the rear wheels have been built, it is easier to describe how to bend them both at the same time. Directions for bending both the handrims and the fenders are included in this chapter. The fender has been designed to fulfill several functions at once:

- 1) When folding the chair, the fenders and the seat guide hooks serve to guide the seat bars as they slide up and down.
- 2) The fender serves as an armrest, and can support a higher armrest if needed.

Conventional fender/armrests need to be removable to allow the rider to slide in and out of the chair sideways. The ATI-Hotchkiss fender/armrests are low enough that they do not need to be removable.

- 3) On a conventional wheelchair the fender is square. Our curved fender helps to reduce the stresses on other parts of the chair by giving the frame more flexibility.

For most riders, the ATI-Hotchkiss fender performs all the functions of an expensive removable desk arm while significantly reducing the number of parts and brazed joints. Thanks are due to the wheelchair makers in the Philippines and Japan for the concept of a curved fender bar.

## MAKING A FENDER FOR A 24" WHEEL

### MATERIALS

ITEM	QUANTITY
3/4" O.D. tubing or 1/2" thin wall conduit	1 piece, 5 feet (152 cm) long
1/2" x 1/8" (12 mm x 3 mm) steel bar	2" (5 cm)

### JIGS AND BENDERS USED

- Wooden Tubing Bender and Fender Die (11-1/2" (29.2 cm) radius die for a 24" wheel; 12-1/2" (31.8 cm) radius die for a 26" wheel)
- Brake Catch and Stop Welding Jig

(The bender and jig are included in the Basic Tool Kit. Instructions for making them can be found in Appendixes A and B.)



## DIRECTIONS FOR BENDING A FENDER FOR A 24" WHEEL

It is difficult to bend a perfect fender the first time. The Basic Tool Kit includes a sample fender for a 24" wheel. We have also included diagrams for fenders for both 24" and 26" wheels. These diagrams can be enlarged to full scale drawings. Comparing the fender you are bending to either a sample fender or full scale diagram will help you to make a fender that fits.

1) Cut two pieces of tubing 30" (76cm) long. Measure and mark the tubing as shown. Mark all the way around the tubing.

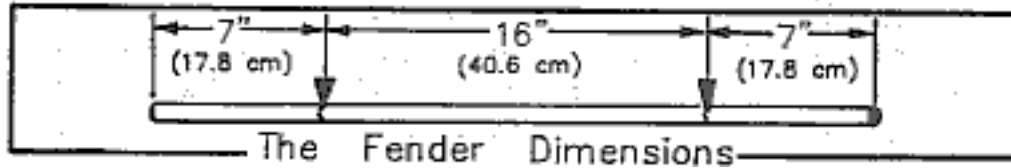

2) Bolt the 11-1/2" (29cm) bending die to the wooden fender bender. The wooden bender should either be bolted to a workbench, held in a vise, or attached to a wall near a corner.

3) Line up one of the marks on the tubing with the bottom edge of the bending die. Loosen the nuts on the bending chock and move the chock until it presses against the tubing. Then tighten the nuts to hold it in place.

4) Bend the tubing around the die until the other mark touches the die. Use a cheater pipe (a piece of pipe that fits snugly enough over the fender tube) to help make the bend. The tubing will spring back slightly.

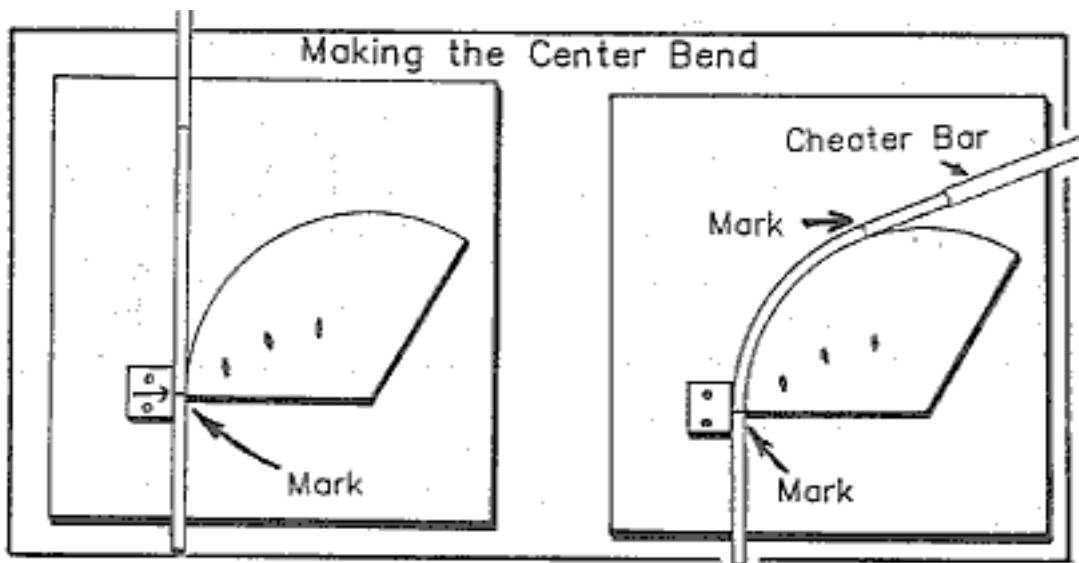

5) Check your bend against the sample fender from the Basic Tool Kit. If you don't have a sample, draw a full scale diagram from the diagram found at the end of this chapter and use it to check the accuracy of your bend.

6) Turn the fender over, and line up one mark with the top of the bending chock. Only 7" (18 cm) of tubing should extend above the top of the bending chock. Slip your cheater pipe 1-1/2" (38 mm) over the end of the tube. Sight along the bender to make sure that the first bend is in the same plane. Bend the end of the tube until the cheater pipe touches the end of the die. Again, the tubing will spring back slightly. Check the bend against a sample fender. A finished fender should lay flat on the floor or table.

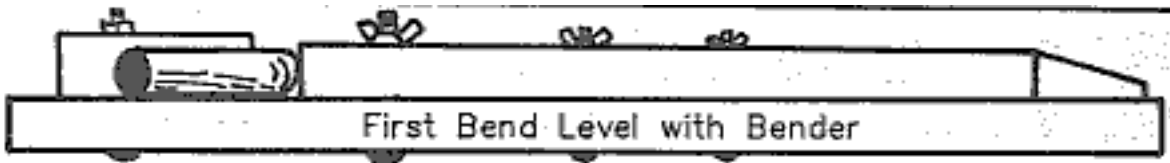
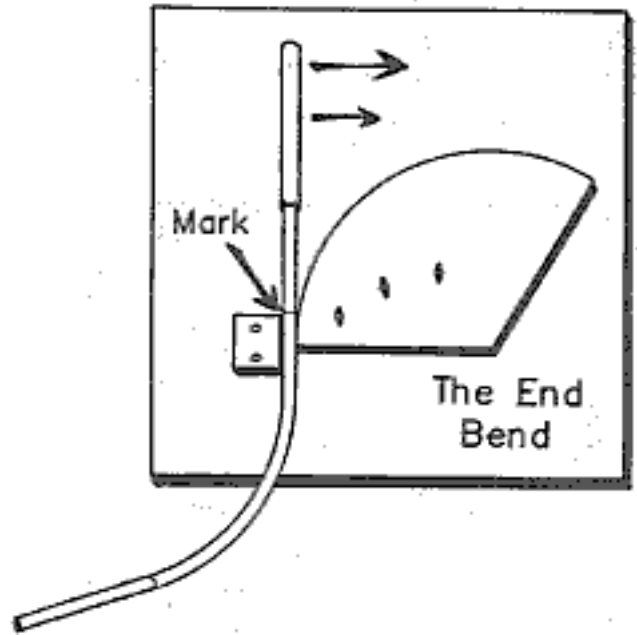

[Table of Contents](#)

# Center for International Rehabilitation

## Chapter 9 Making the X-Brace Halves



The x-brace supports the seat and allows the chair to fold to a width of twelve inches (30.5 cm) or less. This is an important feature for riders who wish to fit their chair in the aisle of a bus, pack it on the side of a donkey, or throw it in the trunk of a car. If the x-brace is well made, it will also give the chair some flexibility, allowing all four wheels to remain on the ground while riding over uneven terrain.

Each x-brace half has four basic parts:

- 1) the seat support tube,
- 2) the guide hook (it attaches the seat support tube to the back of the frame),
- 3) the crosspiece (square tube) and reinforcing washers,
- 4) the bottom tube (which slides onto and rotates around the sideframe).

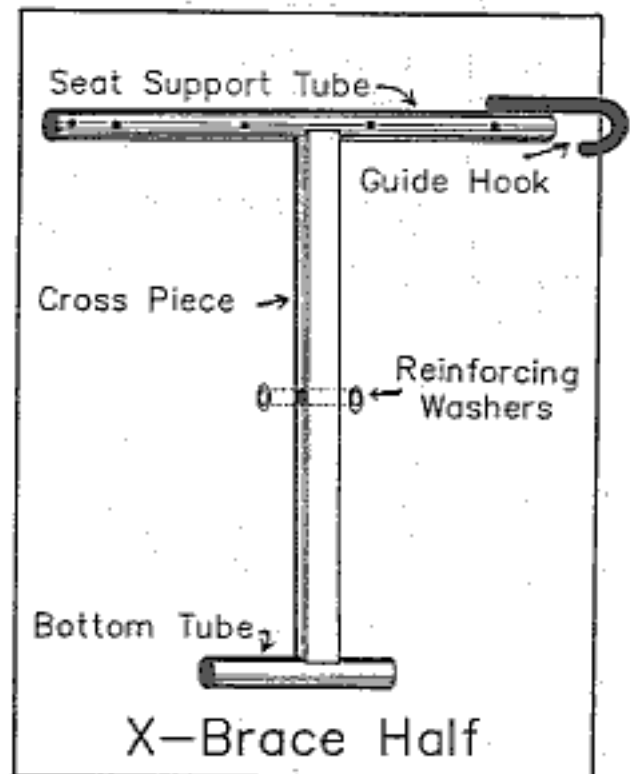

# MATERIALS FOR ONE X-BRACE (TWO HALVES)

ITEM	QUANTITY	PART OF CHAIR
1" O.D. tubing	2 pieces, 16" (40.6 cm) long	seatsupport tubes
1" O.D. tubing	2 pieces, 6" (15.2 cm) long	bottom tubes
3/8" (10 mm) solid steel rod	2 pieces, 6" (15.2 cm) long	guide hooks
3/8" (10 mm) I.D. washers	4	reinforcers
1" square tubing*	2 pieces, 17" (43.2 cm) long	crosspieces

\* 17" is a typical length for the crosspieces. Crosspiece length will vary according to the width and height of the seat. Chapter 4 includes a description of how to determine the appropriate seat width and height for a customer. Chapter 4 also includes a chart that lists the lengths of crosspiece tubing that are appropriate for wheelchairs with different seat widths and heights.

## JIGS USED TO MAKE THE X-BRACE HALVES

- Seat Support Tube Drilling Jig
- X-Brace Welding Jig
- Crosspiece Drilling Jig

The jigs can be purchased as part of the Basic Tool Kit; they can also be made locally by following the directions in Appendix B.

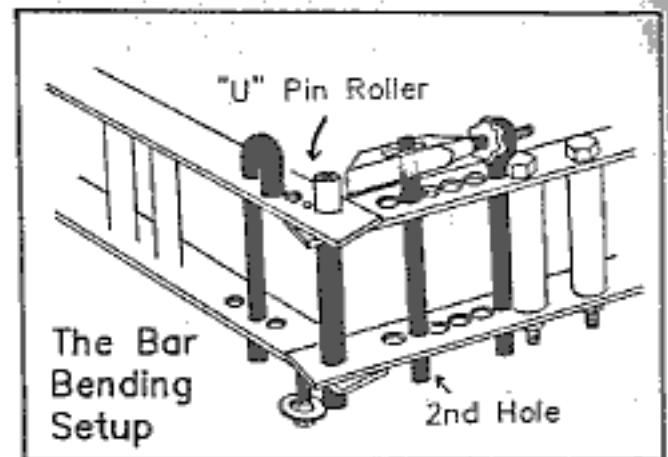

## DIRECTIONS

1) Set up the Hossfeld style bender to bend rod, using the U-pin roller mounted on the center pin as a 1-1/16"

(2.7 cm) die. See [Chapter 6](#) for more detailed instructions on setting up the bender.

2) Begin by making the two seat guide hooks. Cut two 6" (15.2 cm) lengths of 3/8" (10 mm) solid steel rod. Round off both ends of the rod on a grinder.

3) Position the rod in the bender so that the tip of the eye bolt bending dog touches the rod about 1/8" (3 mm) back from the end of the rod. Tighten the thumb nut and bend each piece of rod 180° as shown. Compare this bent hook to a finished sample.

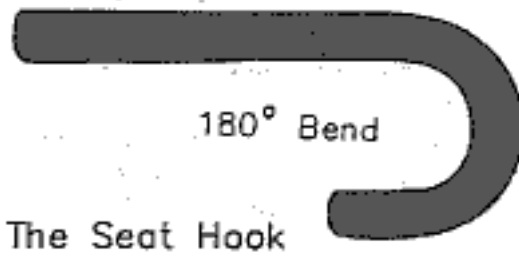
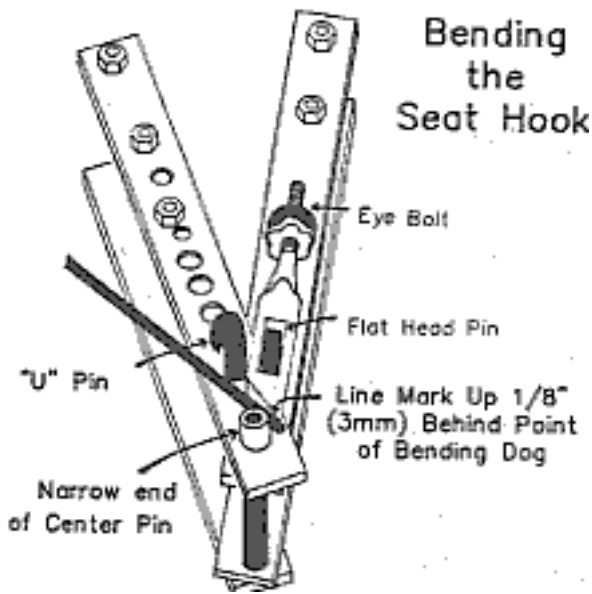

4) Cut two 16" (40.6 cm) lengths of 1" O.D. tubing for the seat support tubes. Place them in the hole drilling jig. Drill five holes all the way through each tube. These holes will be used to attach the seat fabric. (Directions for making the hole drilling jig are found in Appendix B.) Scribe a line 8-1/4" (21.6 cm) from the front end of one tube and from the back end of the other tube. The front end is the end with a hole drilled 1/2" from the end of the tube.

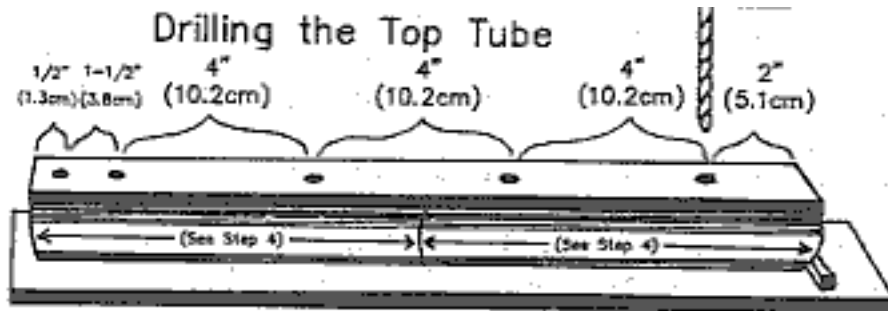

5) Cut two 6" (15.2 cm) lengths of 1" O.D. tubing for the bottom tubes. Scribe a line 3-1/4" (8.3 cm) from one end of each bottom tube.

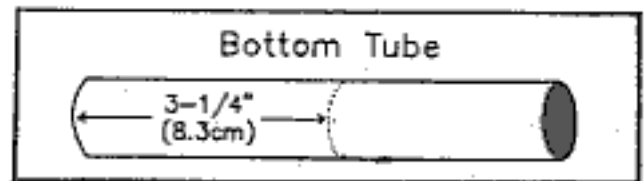

6) Cut two 17" (43.2 cm) lengths of 1" square tubing for the crosspieces. Using an 8-inch half round file or a shaped grinder, file both ends of each crosspiece to make a trough 1/4" (6 mm) deep as shown. Pinch the ends of the crosspiece tubes so they fit snugly against the round sides of the seat support tubes and bottom tubes.

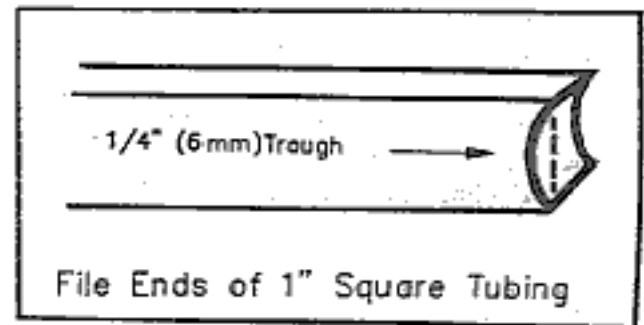

NOTICE: SEE NEW JIG DESIGN.

The following diagrams show the welding of the x-brace on a jig made of plywood. This type of jig must be protected with sheet metal to keep it from burning up when the seat guide hooks are welded on. Our newer design of an all-metal jig will last longer; it is described in Appendix B. Both jigs work the same way; the following instructions apply to either the plywood or the all-metal jig.

7) Place the seat support tube across the top of the x-brace welding jig. The front end of the seat support tube should be on the left side of the jig (see drawing on page 67). Place a crosspiece tube in the jig to the right of the vertical block as shown. The left edge of the crosspiece tube should be in line with the mark on the seat support tube.

8) Slide a 12" (30 cm) long piece of sideframe tubing (7/8" O.D. or equivalent) into a bottom tube of the X-brace (the 6" [15.2 cm] length of 1" O.D. or equivalent tubing). Place both on the jig, clamped against the bottom tube support blocks as shown. Align the mark on the tubing with the left edge of the crosspiece tube.

The jig has been made for a 17" (43.2 cm) crosspiece. If you are making a longer x-brace add enough 1" (2.54 cm) wooden spacers between the bottom tube and the support blocks to adapt the jig to the desired length. If you need to make an X-brace with 15 or 16" long crosspieces, rebuild your jig by connecting the bottom tube support blocks 1" or 2" closer to the other end of the jig.

9) Before clamping all the tubes in place, be sure that the holes in the seat support tube are at the correct angle. Put a drill bit through one of the holes in the seat support tube. Sighting along the drill bit, adjust the tube until the drill bit is parallel to the slanting block mounted near the middle of the jig (see the diagram).

10) Clamp the tubes securely in two directions (to the jig board and to the wooden blocks).

11) Place a guide hook on the right slanting block as shown. Put a 7/8" diameter tubular spacer (or a metric equivalent of the diameter of the sideframe tube) between the end of the seat support tube and the hook. Push the hook toward the seat tube until it bumps against the spacer block. Clamp it in place with the washer and nut. (When making the other x-brace half, the back of the seat support tube and the seat guide hook will be on the left side of the jig.)

12) Braze the two ends of the crosspiece onto the seat support and bottom tubes. Tubing tends to warp when it is heated and cooled on only one side. If these pieces warp, the chair is likely to be poorly aligned, difficult to push, and difficult to fold.

To prevent warping, use the T-joint brazing technique that follows. Do not get the steel tubing any hotter than is necessary to melt the brass.

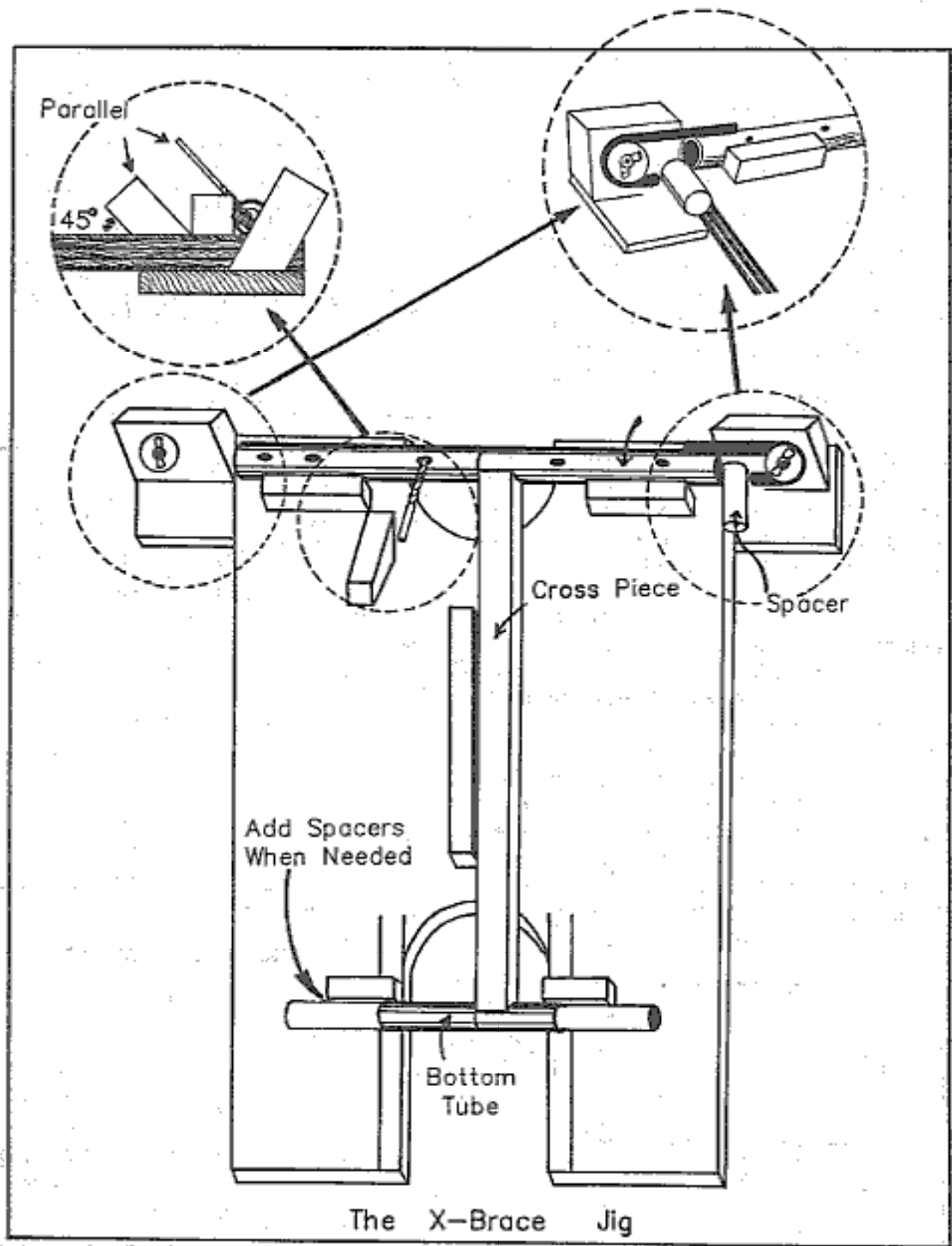

The X-Brace Jig

### 13) T-JOINT BRAZING

- a) Tack the joint on either side.
- b) Starting on one side, braze from the tack up to the center.
- c) On the other side, braze from the tack to the center.
- d) Turn the piece over and repeat the same procedure.
- e) If there is some warp in the tubing, heat the opposite side of the tubing to a very dull red and let it cool. This should help to straighten out any warping.

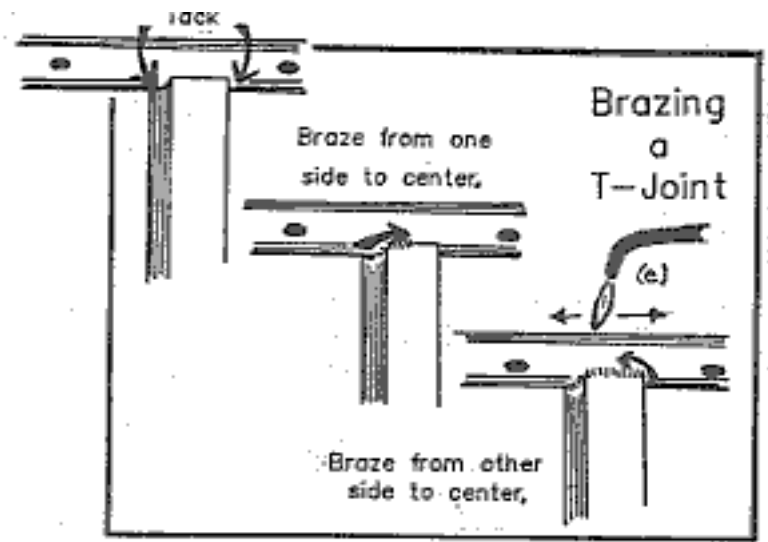

- 14) Remove the first x-brace half from the jig and make the other x-brace half. Put the seat support tube with the front end on the right side and the seat guide hook on the left side. Other than this change, set up the jig exactly the same.

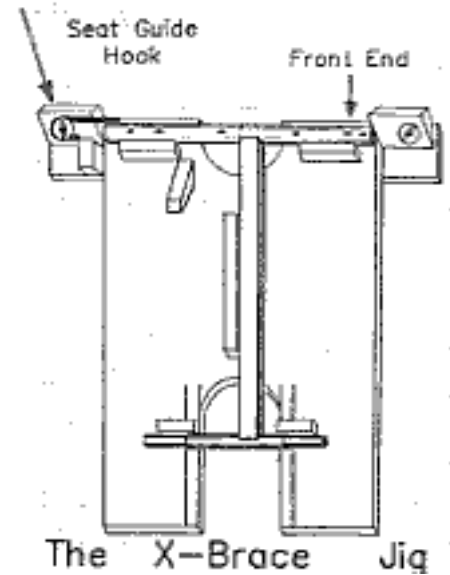

- 15) Place one of the x-brace halves in the drill press vise. Lay the crosspiece drilling jig on top of the crosspiece. Center the hole and drill all the way through the tubing. Repeat this procedure on the other x-brace half.

- 16) Weld a 3/8" (10 mm) I.D. washer around both sides of the center hole in each x-brace half. After welding the washers on, bore only the outside hole of each x-brace half to 7/16" (4.5 mm). This will give the chair some added flexibility. (The outside holes are on the same side as the short ends of the end tubes.)

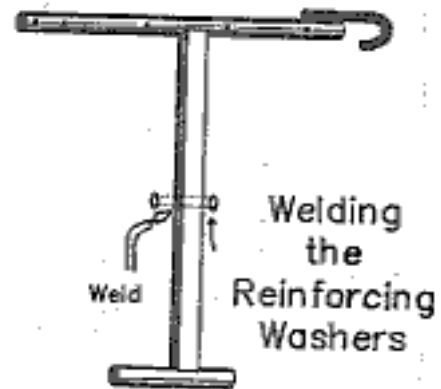
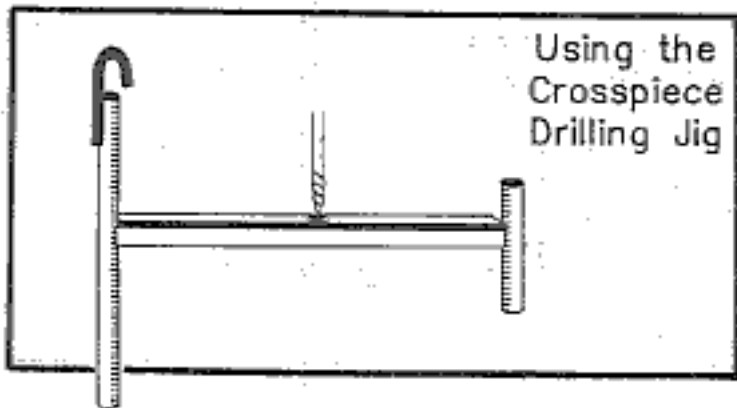



# Center for International Rehabilitation

## Chapter 10 Making the Frame

This chapter describes how to finish making the frame parts and how to assemble the frame. The assembly is a three-step process: attaching the x-brace halves, making the final bends in the sideframe tubes, and brazing the parts of the frame onto the sideframe tubes in the correct positions. It is important to do these steps in the order given. After the frame is complete, it can be sanded smooth, primed, and painted.

Each half of the chair's frame includes one sideframe piece, one x-brace half, one fender, one axle socket reinforcing tube, a rear wheel axle socket, and a caster barrel. (The caster barrel holds the front caster fork and wheel to the frame.) By following the instructions in the previous chapters, you have already made all of the parts of the frame except the rear axle sockets, the caster barrels, and the rear axle socket reinforcing tubes.

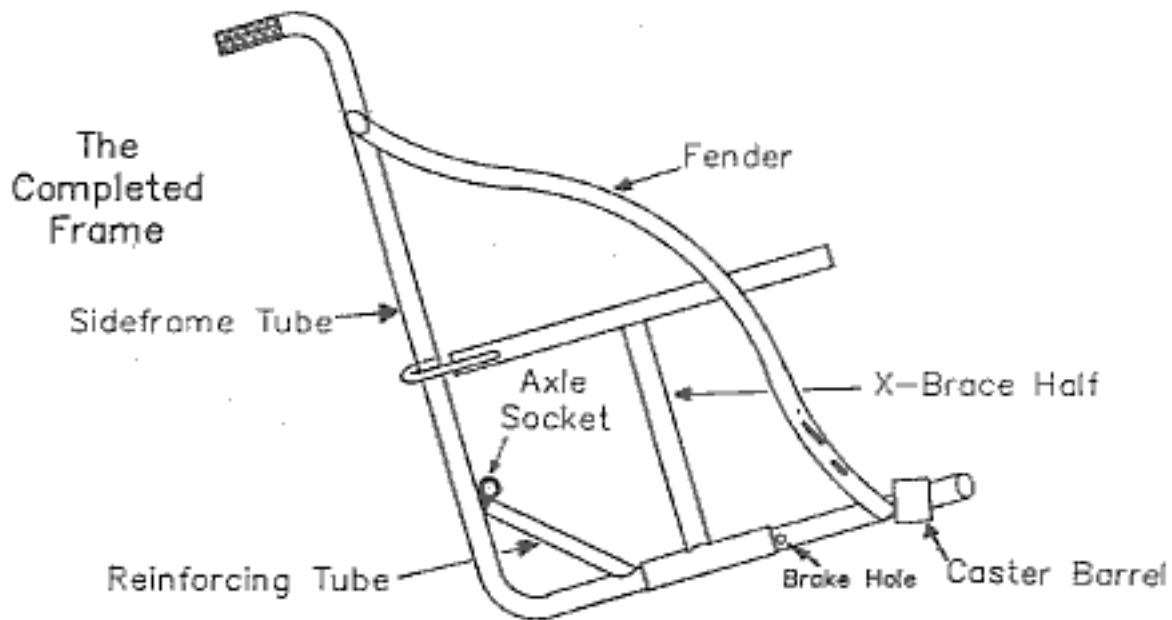

## MATERIALS

ITEM	QUANTITY & SIZE	PART OF CHAIR
5/8" I.D. tubing with thick walls*	2 pieces, 1-1/2" (3.8 cm) long	rear axle
1-1/2" O.D. tubing with 1/16" wall thickness	2 pieces, 1-3/4" (4.4 cm) long	caster barrel
3/4" thinwall tubing	2 pieces, 8" (20.3 cm) long (these will be cut to fit)	axle socket reinforcing tube

sideframe (bent in Chapter 7)	2	sideframe
fender bar (made in Chapter 8)	2	fender
x-brace half (made in Chapter 9)	2	x-brace
fine thread 3/8" bolt	1 bolt, 3" (8 cm) long	x-brace bolt
3/8" (10 mm) I.D. washer	4	x-brace spacer
3/8" (10 mm) I.D. lock nut	2	x-brace bolt

\* The most common type of thick wall tubing with a 5/8" inside diameter is called 1/2" waterpipe. Its actual outside diameter is about 7/8". The axle sockets must be cut exactly square on each end so that the bearings are not worn unevenly.

## JIGS OR BENDERS

- Sideframe Brazing Jig

Instructions for making this jig are found in Appendix B. The jig can also be ordered as a part of the Basic Tool Kit.

## DIRECTIONS FOR MAKING THE FRAME PARTS

Before assembling the frame, you will need to make two of the three remaining frame parts--the rear axle sockets and the caster barrels. The axle socket reinforcing tube will be cut to fit after the axle sockets and x-braces are welded in place.

1) To make the caster barrels, use the tubing cutter to cut two 1-3/4" (4.4 cm) lengths of 1-1/2" O.D. tubing that has a wall thickness of 1/16".

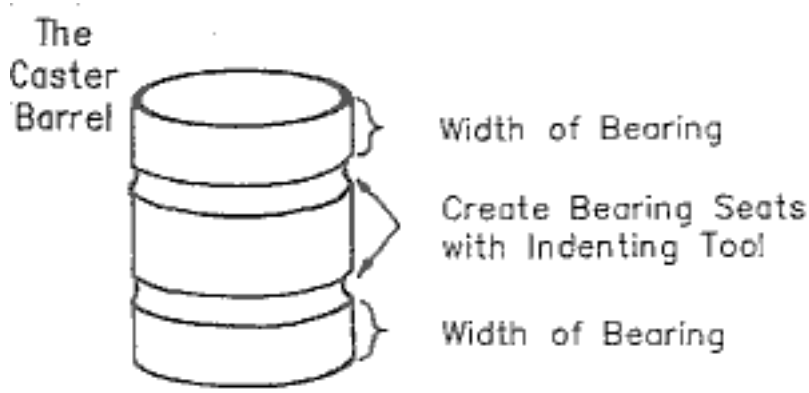

2) Use the tubing cutter with the indenting tool to make bearing seats in the caster barrels (see Chapter 6).

Bearing seats can also be made by welding a short piece of tubing or two rings of heavy steel wire inside the caster barrel. If tubing that fits inside the caster barrel is not available, slit a tube on one side and squeeze or expand it until it fits.

3) To make the axle sockets, use a hacksaw to cut two 1-1/2" (3.8 cm) lengths of 5/8" I.D. tubing with walls about 1/8" thick (1/2" waterpipe has these dimensions). It is very important that both ends of the axle socket are square.

4) After the axle socket pieces are cut, check them in two directions to see if they are square. Use a hand file to make them exactly square if necessary.

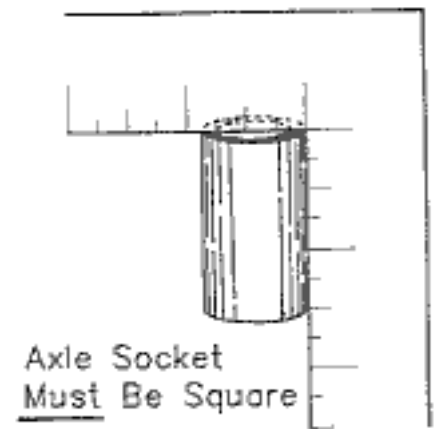

## DIRECTIONS FOR ASSEMBLING THE FRAME

Once you have made the caster barrels and axle sockets, you can begin to assemble the frame. Assembling the frame is a three step process:

- 1) putting the x-brace halves on the sideframe,
- 2) making the third bend in the sideframe pieces,
- 3) brazing the frame components onto the sideframe tubing.

**Do not do these steps in a different order!! It is impossible to put the x-brace halves on after the third bend has been made; it is also impossible to make the third bend once the caster barrels have been welded to the frame!**

1) Slide an x-brace half onto each main side frame tube. The guide hooks should be toward the back of the chair as shown in the diagram. Make sure the seat mounting holes are vertical when the frame is held as in the diagram. If not, interchange the two x-brace halves.

2) Once the x-brace halves are on the sideframes, you can put the third bend in the sideframe tubes.

**DO NOT START THE NEXT BEND UNTIL AFTER YOU HAVE PUT ON THE X-BRACE HALVES. IT IS IMPOSSIBLE TO PUT ON THE X-BRACE AFTER YOU HAVE MADE THIS BEND!**

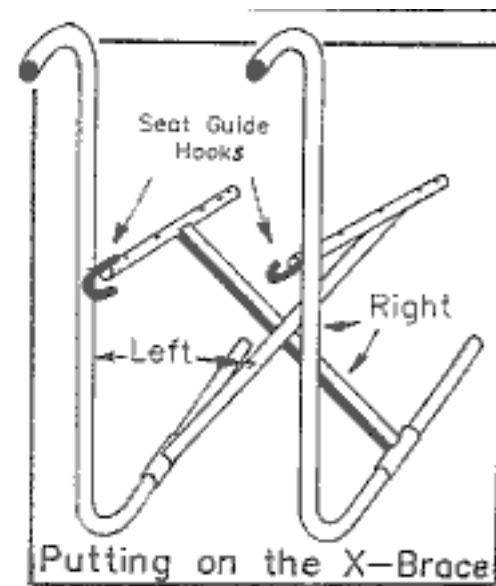

3) Set up the Hossfeld type bender to bend tubing using the die set for 7/8" O.D. tubing with a 2" Center Line Radius.

4) Start with the right sideframe tube. Make a mark on the sideframe tube 17-1/2" (44.5cm) forward from the back of the sideframe. Line up this mark with the mark on the form die.

Position the sideframe tube in the bender with the handle end up and tilted 10° to the right as

shown. Note: tilting the sideframe 10° is optional. A 10° tilt will result in footrests that fold closer to the wheelchair seat. Check the angle by sighting along a protractor placed on the form die. After clamping the vise-grips onto the tubing next to the back block, bend the end of the sideframe tube 45°.

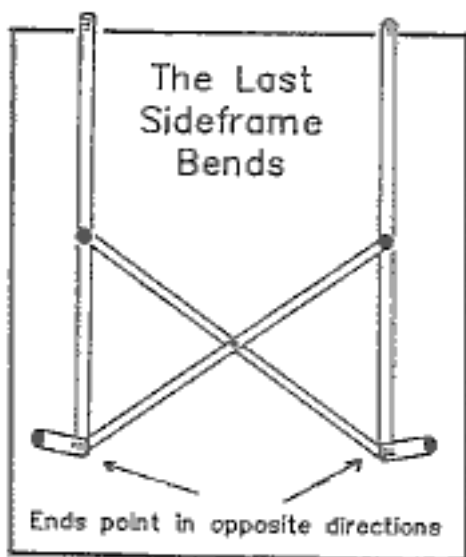
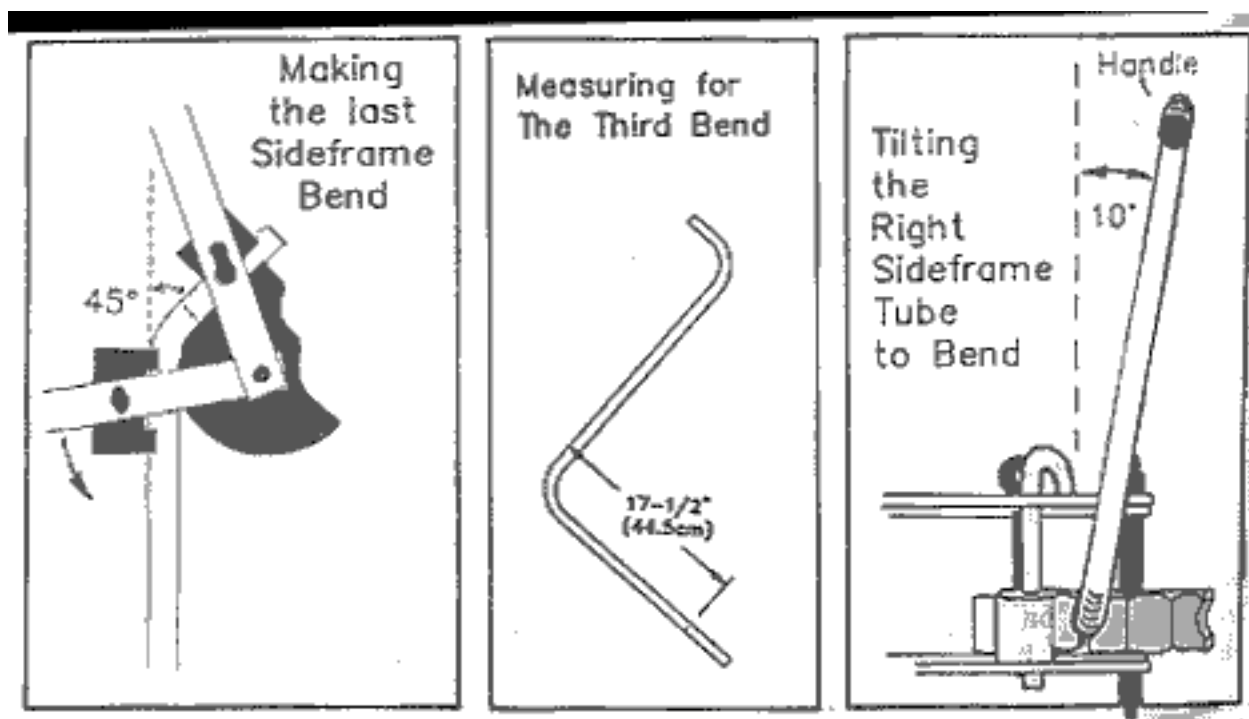

5) Position the left sideframe tube in the bender with the handle end down and tilted to the right 10~ (tilting the sideframe is optional). After clamping the vise-grips onto the tubing next to the back block, bend the end of the sideframe tube 45~.

Note that the ends of the two sideframe tubes must point in opposite directions toward the outside of the chair.

Do not cut off the excess tubing on the front of the sideframe pieces. After you make the footrests, you can cut it to the correct length.

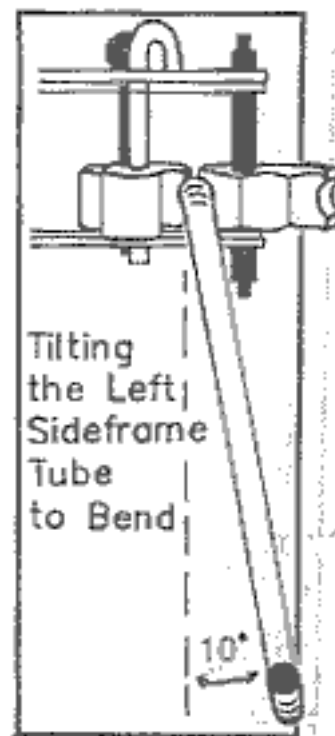

6) The sideframe brazing jig can be used for wheelchairs with either 24" or 26" wheels. If your chair has 24" wheels, bolt the two axle sockets onto either side of the lower jig tube. If the chair you are building uses 26" wheels, use the higher tube on the jig.

7) Put the caster barrels (already indented) onto the front bolts of the jig, place the washers on

top and screw them on very loosely.

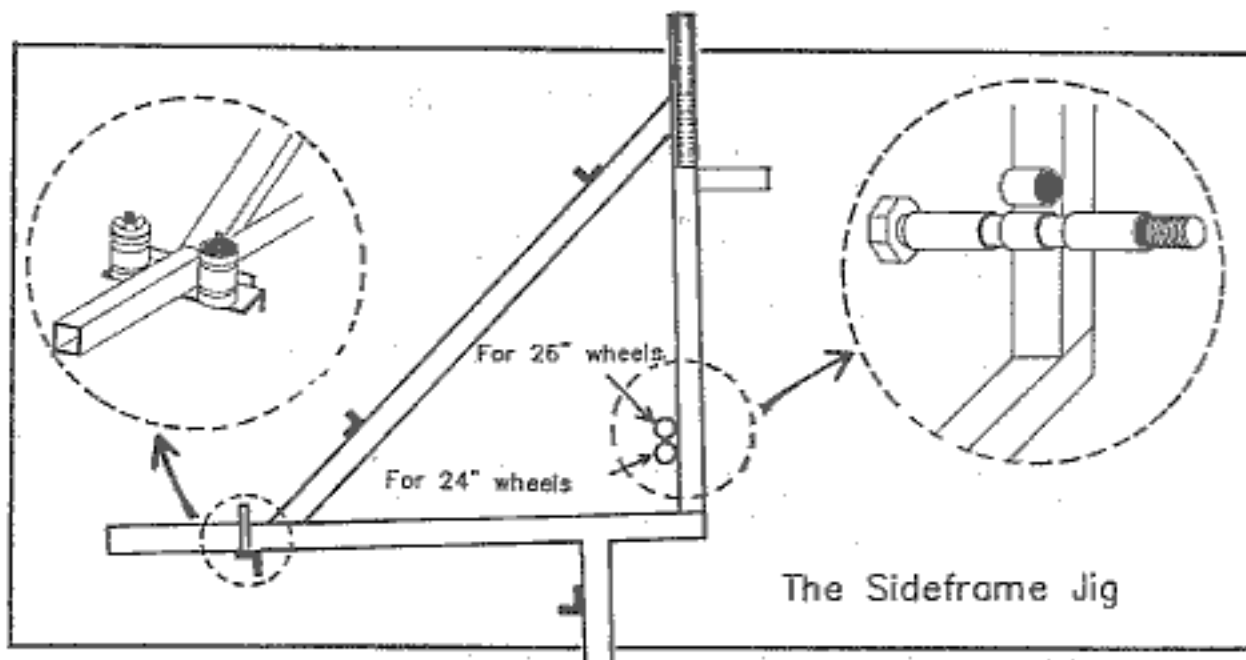

8) Put one sideframe on each side of the jig as shown. Push the frames up against the axle sockets. Press the caster barrels into the frame and against the jig. Clamp the caster barrels in place by tightening the wing nuts.

9) Put one end of the fender up against the caster barrel. It should rest on the jig as shown. If it doesn't, take it off and bend it to the correct shape. For 26" wheels, bolt on the the two jig extensions before putting the fender in place.

Once the bends are correct, the fender will probably stick out past the frame. Mark where it should be cut off, take it off the jig and cut it with a tubing cutter. Weld a conical washer (see Chapter 6) to the end of the fender to cover the sharp edges. Repeat the same procedure with the fender on the other side.

10) Put both fenders back on the jig, and clamp them in place near the top with two wooden blocks connected by a bolt.

11) Tack every joint securely. Remove each sideframe from the jig and finish brazing all the components onto the frame.

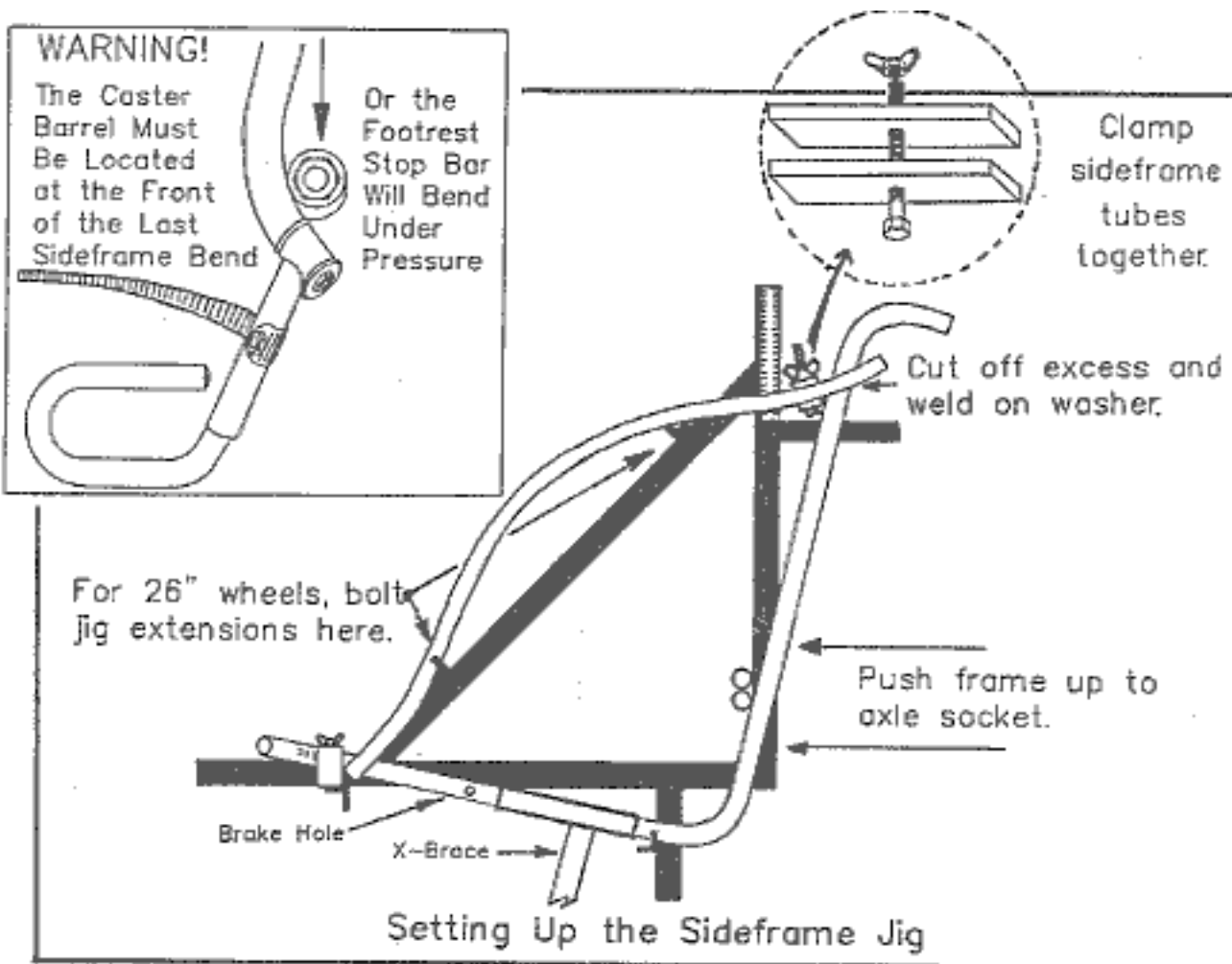

12) With the chair in a half open position, snap the seat guide hooks onto the back of the frame. Only when the chair is in the half open position are the seat guide hooks at right angles to the frame, making it possible to snap them on.

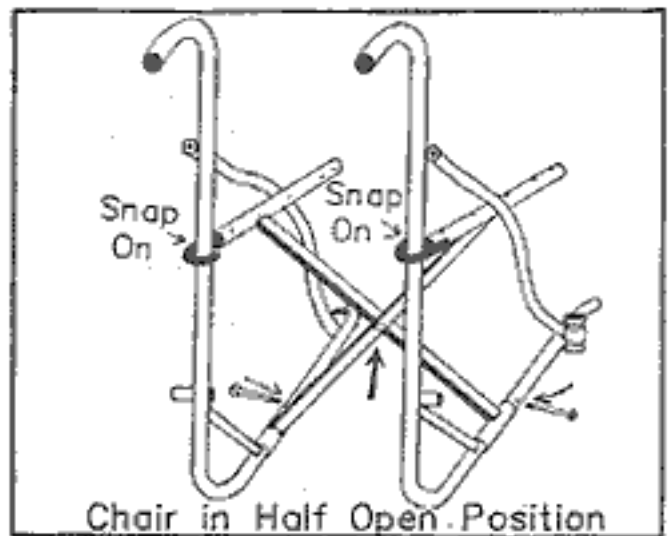

13) Bolt the two halves of the x-brace together using:

- one 3/8" (10 mm) fine thread bolt that is 3" (7.6 cm) long.
- enough 3/8" (10 mm) washers to separate the x-brace halves by about 1/2" (13 mm).
- two locknuts.

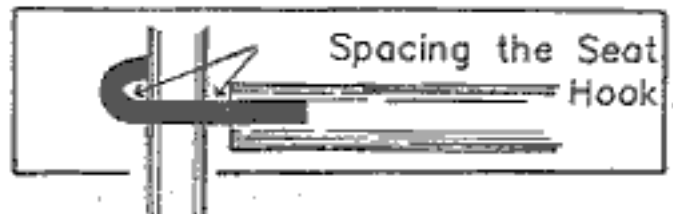

14) Slip 5/16" (8mm) rods or bolts into the brake mounting holes. Slide the x-braces forward until they touch these bolts. In this position, the seat back tubes should be roughly centered in the seat guide hooks (see diagram). If they are not centered, the x-brace or the sideframes may need to be bent back into alignment.

the seat guide hooks (see diagram). If they are not centered, the x-brace or the sideframes may need to be bent back into alignment.

15) Once the x-brace is positioned properly, use vise grips to clamp the bottom tubes to the sideframe tubes.

16) Measure the distance between the back of the bottom tube of the x-brace and the underside of the axle socket. Cut a piece of 3/4" tubing to fit. The top end of the tubing can be cut square, the bottom end should be cut at a 45~ angle as shown. This will become the axle socket reinforcing tube.

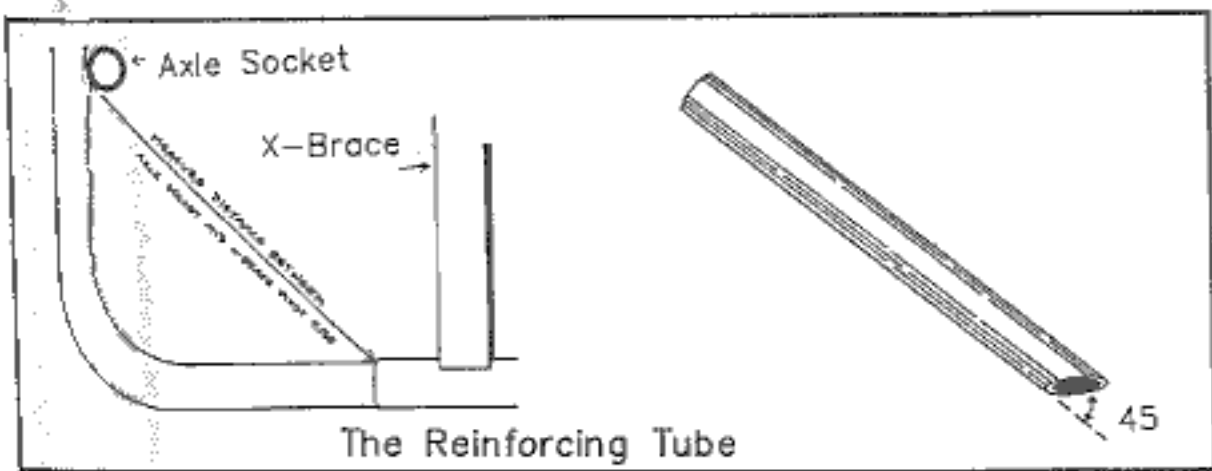

17) Use a vise to crimp the top end of the reinforcing tube. Jam the crimped end into the space between the axle socket and the frame.

18) Partially braze behind the bottom end to hold it in place. Be careful not to weld the x-brace to the frame!

19) Braze the top end to the frame, filling in any gaps with brass.

20) Take the vise grips off the x-brace, and remove the bolts in the brake mounting holes. Tap the x-brace forward as far as it will go. This will get the x-brace out of the way before brazing the bottom of the reinforcing tube. Once the x-brace is moved, finish brazing all the way around the bottom of the tube. File or melt off any brass that accidentally got ahead of the reinforcing tube so that the x-brace can slide back all the way.

21) Repeat this procedure for the other side of the chair.

22) Tap the x-brace back into position. Hold it in place by replacing the bolts in the brake mounting holes.

# Center for International Rehabilitation

## Chapter 11 Building the Rear Wheels

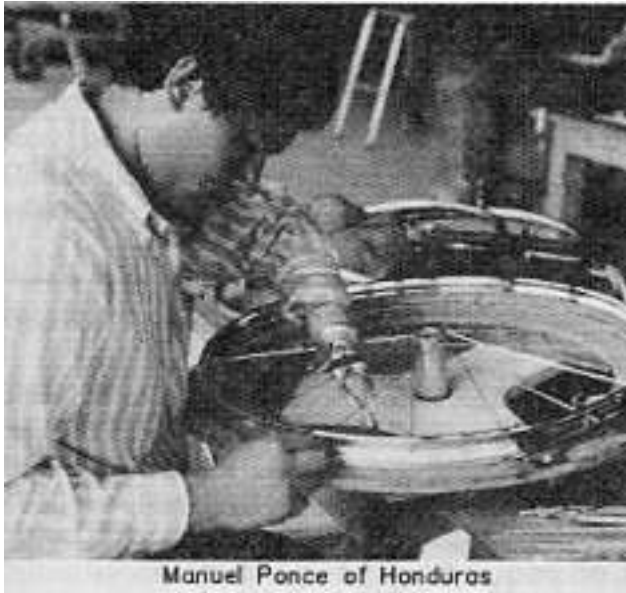

Manuel Ponce of Honduras

Building a wheel that is light, perfectly round, doesn't wobble from side to side, and can withstand the stresses of curb climbing and dirt roads takes a lot of practice. It requires technical skills that can be learned from this chapter, and it requires a good deal of patience. This is a good job to tackle on a day when you are well rested and relaxed.

We prefer to use bicycle rims and tires instead of the solid rubber tires used on many conventional wheelchairs. Not only are bicycle tires less expensive and easier to find, but they give a much smoother ride and are easier to push. Before starting to build the wheel, be sure you know what size wheel your customer needs. Chapter 4 includes a discussion of the various wheel and tire sizes that are appropriate for farm and city use.

Each rear wheel is composed of a hub, a rim and rim strip, spokes and nipples, a handrim, and a pneumatic tire with its air filled inner tube. This chapter outlines the basic procedures involved in wheel building, beginning with the hub and working our way out to the tire.

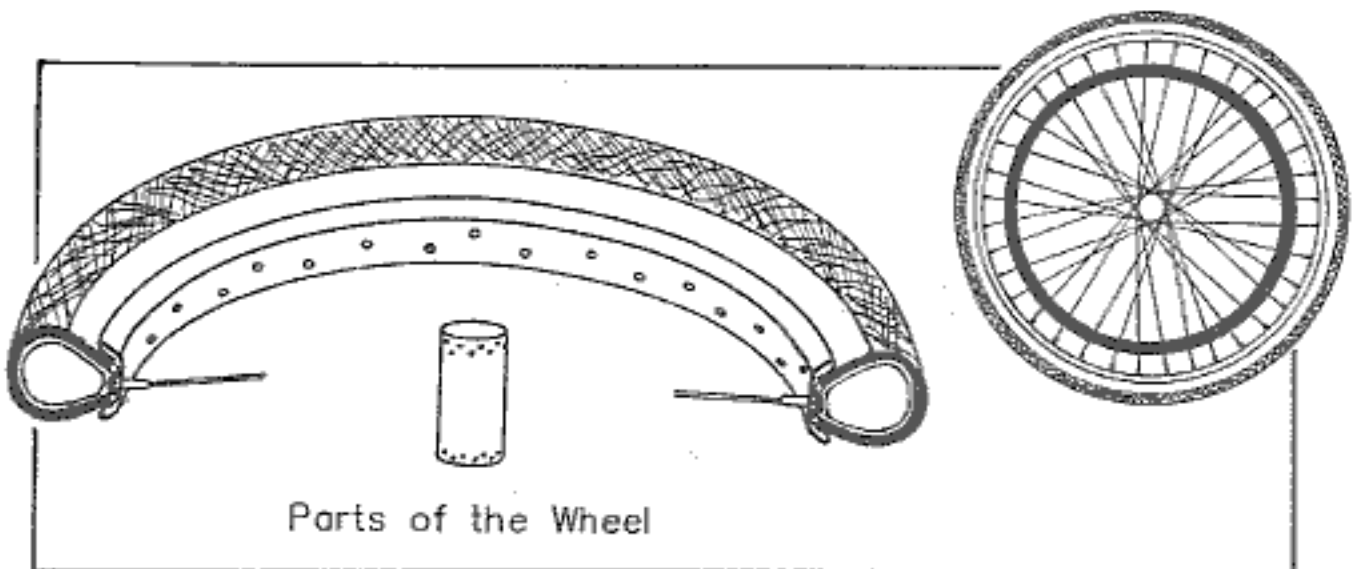



## THE HUB

The hub is the unit in the center of the wheel. It consists of an axle, two sets of sealed bearings that rotate around the axle, a spacer tube that holds the two sets of bearings apart, and a hub casing that fits over the bearings. All of this is held on the wheelchair by a nut that screws onto the axle bolt.

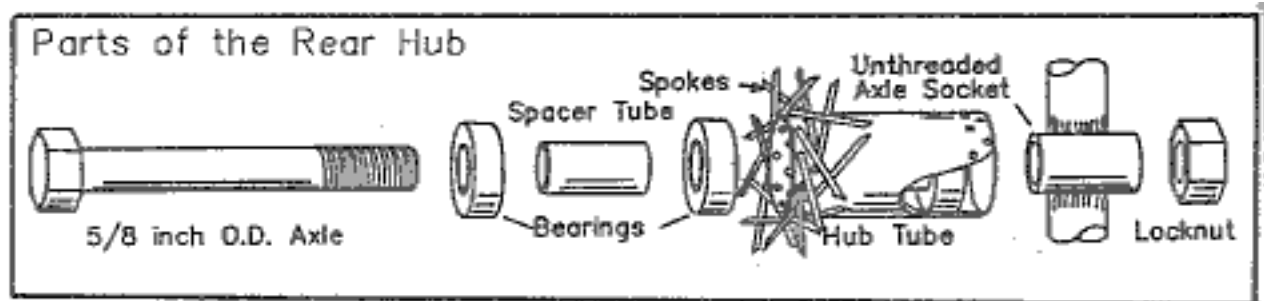

## THE AXLE

The axle is a bolt around which the bearings turn. The axle also attaches the wheel to the frame of the chair. Many commercial wheelchairs use axles that are 1/2" (12 mm) or less in diameter. Since these axles must be made of hardened steel to prevent bending, when they fail, they often fail by cracking. Our chair is designed to use a 5/8" mild steel axle bolt (or a 16 mm bolt with a metric bearing). This bolt is thick enough that it does not need to be hardened. Using a soft (mild) steel bolt reduces the risk of axle fracture. In addition, 5/8" mild steel bolts are inexpensive and widely available. However, it may be difficult to find ball bearings that will fit these bolts.

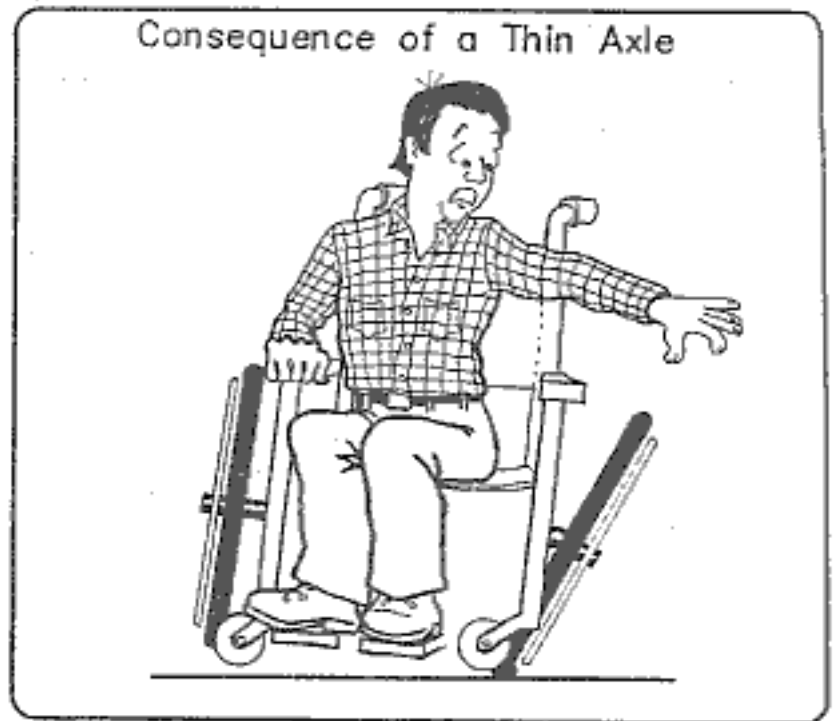

The diameter of most bicycle axles is 3/8" (10 mm) or less. These axles are far too thin to be used on a wheelchair where they are supported only at one end. Wheelchairs that use bicycle axles must have a frame member outside the rear wheel to support the axle. This frame member can increase the weight of the chair, and worse yet, it always increases the width. In the Philippines, bicycle axles have been used on wheelchairs which had no frame member to support the outer end of the axle. As a result, the axles on hundreds of these wheelchairs are bent or broken.

# BALL BEARINGS

Our wheelchair is designed to use sealed ball bearings. Second-hand bearings are sold by many repair shops at low prices. While they might be too old to use in an auto or in power tools, many can be perfectly adequate for a wheelchair. A well chosen used bearing can last for years in a wheelchair if it is kept properly adjusted and lubricated.

It is important that bearings be kept free from dirt and grit. The seals should keep your bearings clean; however, if a used bearing feels gritty when you turn it with your finger, pop out one of the seals with a knife, clean the bearings with kerosene, and add some new bearing grease. Do not smoke during this procedure. If you cannot replace the seal, pack the bearing with grease and put it back onto the axle with the broken seal facing the inside of the hub where there is less dirt.

## BEARING SIZES - MATCHING THEM TO THE AXLE

Different sizes of bearings are sold in different countries. If possible, use bearings that will fit the 5/8" axle. Bearings with an inside diameter of both 5/8" and 16mm will fit the 5/8" axle. If these are not available, get a bearing with a 15mm inside diameter and have the diameter of a coarse threaded 5/8" axle bolt reduced to 15mm in a lathe. Make sure the bearings fit snugly, and be sure to use a locknut on the axle. The following table lists bearings that can be used in the rear hubs and caster barrels.

BEARING #	SIZE	WHERE TO FIND USED BEARINGS	AXLE DIAMETER
#99502h*	5/8" I.D. x 1-3/8" O.D.	Older U.S. or English cars	5/8"
R-10	5/8" I.D. x 1-3/8" O.D.	Older U.S. or English cars	5/8"
#6202	15mm I.D. x 35mm O.D.	Very common; cars and tools	15mm**
#202 or #6202***	16mm I.D. x 35mm O.D.	Some types of power tools	5/8" or 16mm

\*This bearing is available new in quantities of 500 or more for U.S.\$0.85 each plus shipping (1985 price) from:

IKS America - Tel.213/770-2700  
1555 Rosecrans Avenue  
Gardena, California 90249 USA

\*\*Reduce a 5/8" diameter coarse thread bolt to 15mm diameter by turning it on a lathe.

\*\*\*This bearing is also called a #6202 with a special 16mm bore.

# MAKING THE HUBS

## MATERIALS

ITEM	LENGTH OR SIZE	QUANTITY
Tubing:		
1-1/2" O.D., 0.064" wall thickness	3" (7.6 cm) long	2 pieces
3/4" O.D., 0.049" wall thickness*	1-1/2"(3.8 mm) long	2 pieces
5/8" bolt	4-1/2" (11.4 cm) long	2 bolts
Bearings**	1-3/8" x 5/8"	4 bearings

\*1/2" conduit, 1/2" iron pipe, 18 mm tube with 1 mm wall thickness, or any 20 mm tube will also work.

\*\*See the preceding chart for other types of bearings that will work.

## JIG FOR MAKING THE HUBS

- Hub Drilling Jig

Directions for making this jig are found in Appendix B. The jig is also available as part of the Basic Tool Kit.

## DIRECTIONS FOR MAKING THE HUBS

1) Cut a 3" (7.6 cm) length of 1-1/2" O.D. tubing with a tubing cutter.

2) Scratch a straight line along one side of the hub casing. A short piece of angle bar makes a good ruler for drawing this line.

Note: The hub drilling jig must have the same number of holes as the rim.

3) Slide the drilling jig over one end of the hub casing. Line the jig up so that the line scratched on the hub casing intersects one of the holes in the inner ring of the drilling jig.

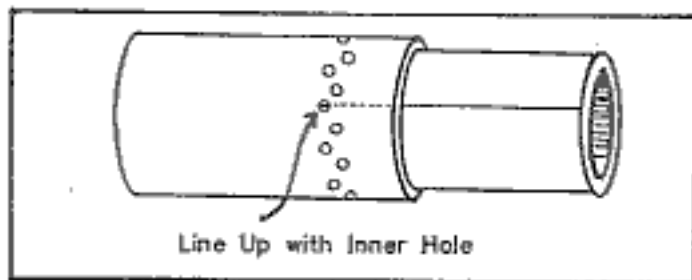
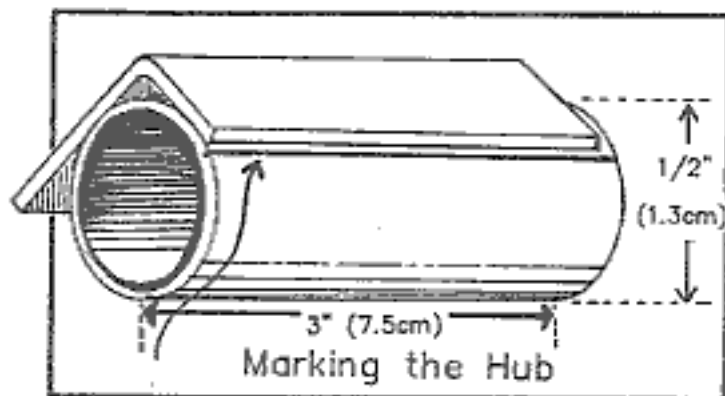

4) Set the drill press to a very high speed. Position the jig and hub in the drill press vise so that the jig is furthest from you.

5) If you are using a hub drilling jig without drill bushings, use the holes in the drilling jig as a guide to drill all of the holes in one end of the hub. Use a 1/8" (3 mm) drill bit. If the spokes will fit through a smaller hole, use a 7/64" drill bit.

The hub drilling jig found in the Basic Tool Kit has two guide holes reinforced by drill bushings. The bushings prevent these guide holes from widening with use.

To use this type of jig, first drill two holes in the hub using the two holes reinforced with drill bushings as guides. Next rotate the hub to the right (clockwise) until the upper hole just drilled in the hub is lined up with the next hole in the upper ring of the jig. Pin the hub in place by inserting a nail.

Once the hub is pinned in place, drill the next two holes using the drill bushings as guides. Continue this process of drilling, rotating, and pinning until all of the holes in one end of the hub are drilled. To ensure an even spacing of the holes, always put the nail through the very first hole that you drilled in the hub.

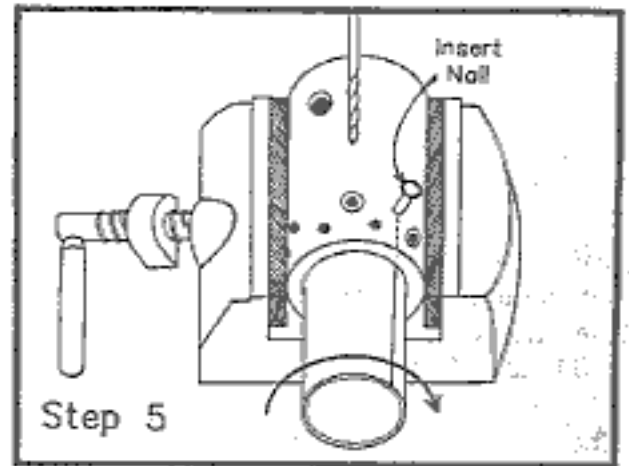
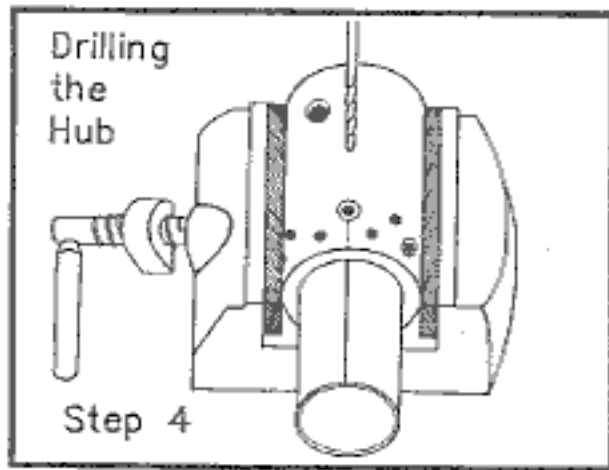

6) Slide the drilling jig onto the other end of the hub casing. Position the jig and hub in the vise as before. Twist the hub in the jig until the scribed line on the hub casing points between two holes in the jig. The lower hole must be to the right of the scribed line (see diagram). It is important to position the jig this way because it will affect the wheel spoking pattern. Drill the rest of the holes in the hub, always inserting a nail in the first hole you drilled in this end of the hub.

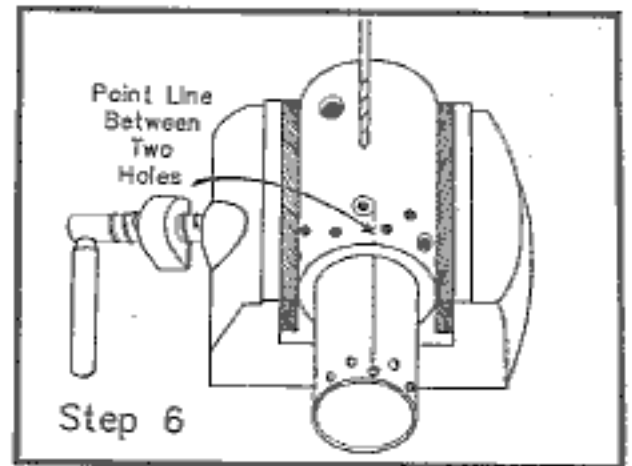

7) Slide the bearings into the ends of the hub casing, putting the 1-1/2 inch spacer tube between them. If the bearings fit loosely, remove them and reduce the diameter of the hub casing with the indenting tool until the hub casing is small enough to grip the bearings. (See Chapter 6 for instructions on how to indent the tubing).

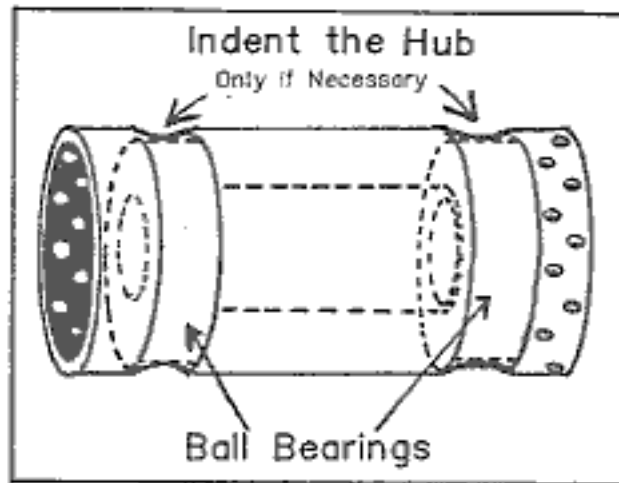

**Don't indent the hub to make a stop for the bearings! The heads of the spokes will keep the bearings from falling out and the spacer tube will keep the bearings apart.**

## AN ALTERNATE HUB DESIGN

If the hub casing tubing (1-1/2" O.D.) is in limited supply, it is possible to make a split hub casing using half of the amount of 1-1/2" O.D. tubing. This design was invented by Omar Talavera of Nicaragua who split the hub on his own chair in order to have enough hub casing tubing to make another chair.

In addition to using less tubing, hub casings that are made according to this design will not need to be indented to hold the bearings. The disadvantage of this design is that the wheels will not turn quite as freely. This hub design adds about 1/4 of a pound (0.11 kg) of drag to the chair.

This hub can be made using the same materials as were used in the standard hub design; however, the spacer tube will not need to be exactly 1-1/2".

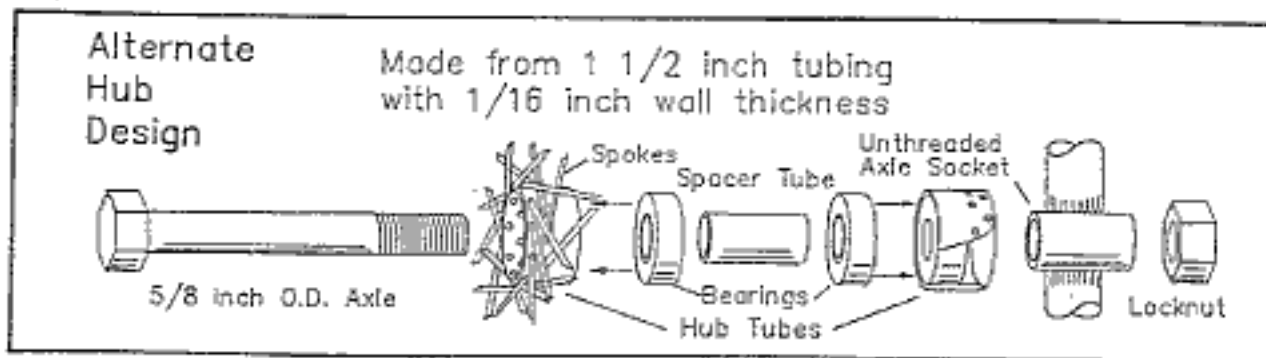

When drilling these hub casings, it is easiest to put a longer piece of tubing in the drilling jig, drill it, then cut it to size.

## SPOKING THE WHEEL

Wheelchair wheels that use our hub design can be spoked with a three, four, or five- cross

spoking pattern. Five-cross means that each spoke will cross five other spokes as it stretches from the hub to the rim. The more the spokes cross each other, the more flexible the wheel is, and the less likely it is for the spokes to break. We recommend using either a four-cross or five-cross spoking pattern on the rear wheels. The length of the spokes will depend upon the spoking pattern as well as the size of the wheel.

## TABLE OF SPOKE LENGTHS FOR 40-SPOKE WHEELS

RIM SIZE	SPOKING PATTERN	SPOKE LENGTH
24" x 1-3/8"	5X	10-1/2" (267 mm)
24" x 1-3/8"	4X	10-1/4" (261 mm)
24" x 1-3/8"	3X	10-1/16" (256 mm)
24" x 1-3/4" or 2-1/8"	5X	9-7/8" (250 mm)
24" x 1-3/4" or 2-1/8"	4X	9-5/8" (244 mm)
24" x 1-3/4" or 2-1/8"	3X	9-3/8" (239 mm)
26" x 1-3/8"	5X	11-1/2" (293 mm)
26" x 1-3/8"	4X	11-1/4" (287 mm)
26" x 1-3/8"	3X	11-1/16" (281 mm)
26" x 1-3/4" or 2-1/8"	5X	10-13/16" (275 mm)
26" x 1-3/4" or 2-1/8"	4X	10-9/16" (269 mm)
26" x 1-3/4" or 2-1/8"	3X	10-3/8" (263 mm)

The above spoke lengths are correct for a wheelrim with 40 spoke holes. If your wheelrim has fewer spoke holes, increase the spoke length: For 36 spokes add 1/8" (3 mm); for 32 spokes add 1/4" (6 mm); for 28 spokes add 3/8" (10 mm).

The above spoke lengths are also correct for a wheelrim with a fairly flat inside surface. Some rims are indented where the spokes enter the rim; these rims need shorter spokes. To find out whether your rims need shorter spokes, measure the inside

diameter of the wheelrim. Divide this diameter by two to find the radius, then compare this radius with the "normal" radius in the chart below. If your radius is less than "normal", your spoke length should be reduced by the same amount.

### WHEELRIM SIZE "NORMAL" RADIUS (1/2 OF INSIDE DIA.)

24 x 1-3/8	10-3/8" (263 mm)
24 x 1-3/4 or 2.125	10-1/2" (267 mm)
26 x 1-3/8	11-7/16" (291 mm)
26 x 1-3/4 or 2.125	10-5/8" (270 mm)

Most bicycle spokes are 0.080" (2 mm) in diameter. If these spokes are kept tight, they are strong enough for most wheelchair use. For very active wheelchair riding, we recommend 0.105" (2.67 mm) diameter spokes.

## MATERIALS AND JIGS NEEDED TO SPOKE THE WHEEL

- Drilled hub with bearings and spacer tube
- Bicycle wheel rim
- Spokes and nipples
- Spoking board

Instructions for making the spoking board are found in Appendix B; it can also be purchased as part of the Basic Tool Kit.

## DIRECTIONS FOR SPOKING THE WHEEL

1) Set up the spoking board by inserting the 5/8" (or 15 or 16 mm) threaded rod into the center of the rim drilling jig. The rod should stick up about 2-3/4" (7 cm) beyond the nut on one side.

2) Place the hub casing containing the ball bearings and spacer tube on the spoking board. The end of the hub that has the scribed line passing through the hole should be on top.

3) Place the rim on the spoking board. Note that the holes on the rim alternate in a slightly up or down position.

4) Oil the threads of the spokes with light weight machine oil.

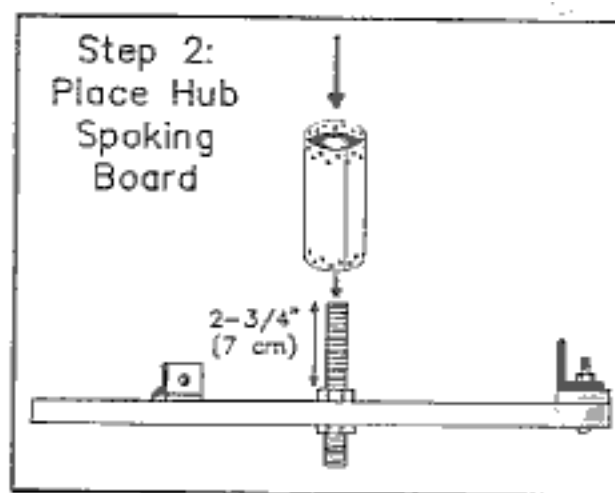

5) Put the first spoke through the hole on the upper end of the hub that was drilled on the scribed line. Connect this spoke to the rim through the lower hole on the rim next to the valve hole. Screw on the nipple two or three turns.

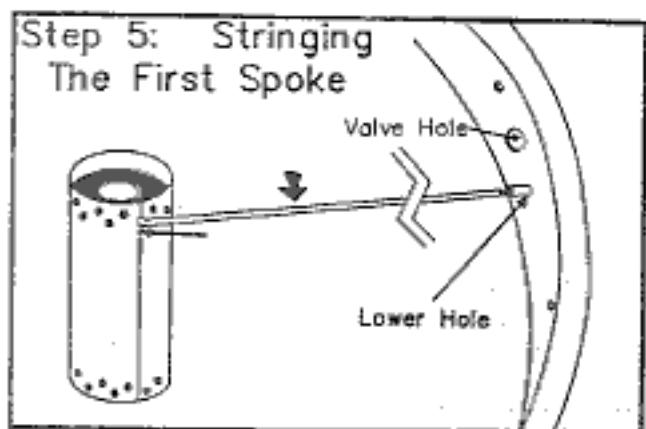

Note that we are putting spokes from the upper end of the hub into the lower holes of the rim. This is the opposite of the spoking system used for bicycles. Our method pulls the upper and lower spokes closer together, giving more space for the rider's fingers under the handrim. Our spoking method also allows us to reduce the width of the chair by 1/4" to 1/2".

6) On the upper end of the hub, insert spokes into all of the rest of the holes in the lower line. All of the bent ends must face in the direction shown in the diagram.

7) Count over four holes and connect the next spoke. Continue this process until all the spokes from this first row have been connected to the rim. Screw each nipple on two or three turns.

8) Twist the hub until the spokes are tight. Be sure that the heads of the nipples are pulled up against the rim, and that the spoke heads are tight against the hub.

9) Insert spokes into the top row of holes in the hub with the heads of the spokes facing in the opposite direction.

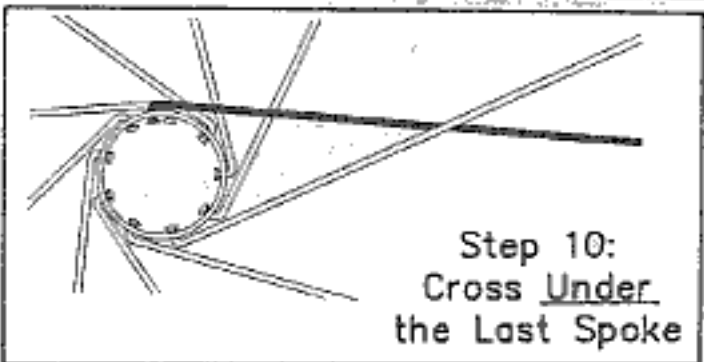
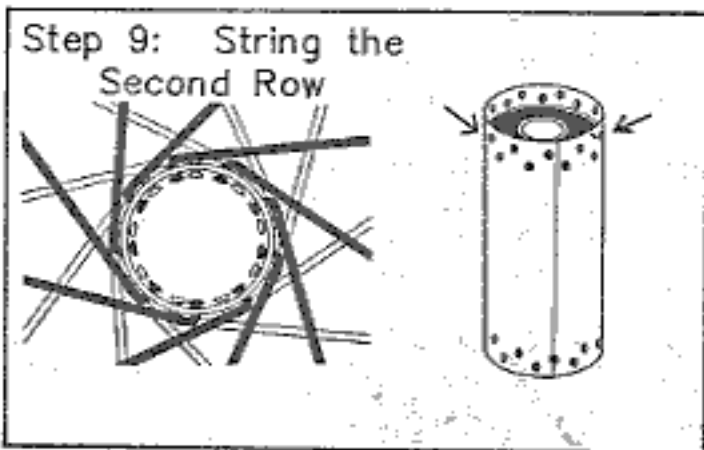
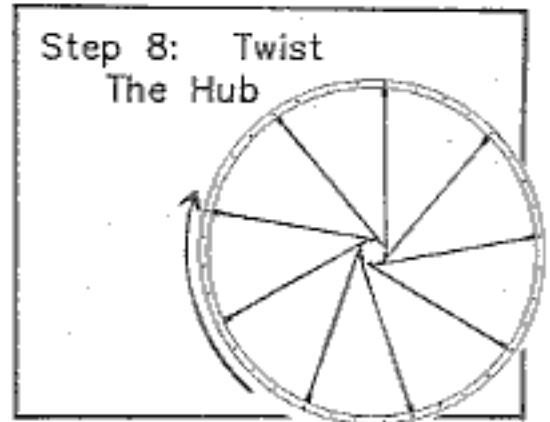
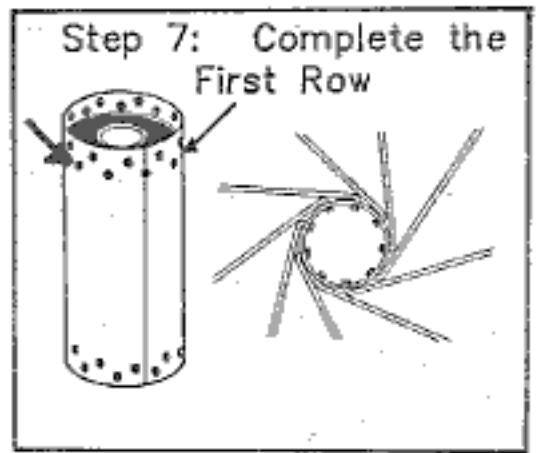

10) Choose any loose spoke; cross it over the top of the spokes that are already attached to the rim. The number of spokes each spoke crosses will depend on the length of the spoke as previously discussed. On the last cross, put your spoke underneath the other spoke (see diagram). This will help to prevent the spokes from loosening up later on. Connect the spoke to the hole in the rim halfway between two other spokes.

11) Attach all the rest of the spokes from the top row on the hub by counting over four holes in the rim for each one. Use the same crossing pattern, lacing each spoke under the last spoke it crosses. Screw on the nipples two or three turns.

12) Turn the wheel over, and replace it on the spoking board.

13) Find the scribed line on the hub. Look at the two holes it passes between. Put the next



spoke through the lower of these two holes. (It should be to the right of the line as you face it.) Connect this spoke through the hole in the rim just in front of (to the left of or counterclockwise from) spoke #1. (See diagram.)

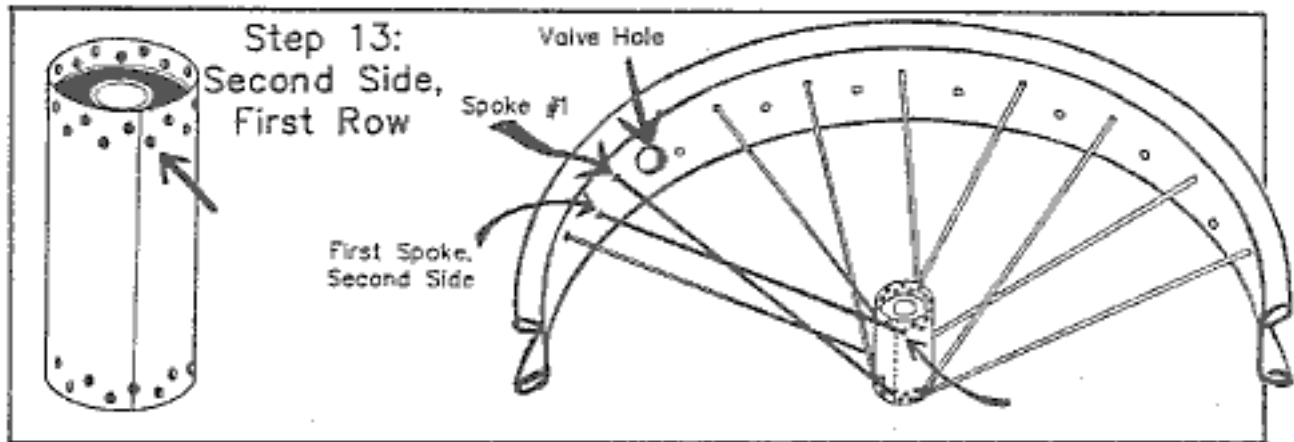

14) Insert spokes through the rest of the lower line of holes on the hub and attach them to the rim through every fourth hole starting with the spoke you connected in step #13. These spokes should face the same direction as the first row of spokes you connected.

15) Insert spokes in the remaining line of holes in the hub. The spokes should face in the opposite direction from the last line of spokes. Connect these spokes to the rim using the same crossing pattern that you used on the first side of the wheel.

16) Holding the wheel rim flat against the spoking board, tighten the spokes all the way around the wheel with your fingers. Continuing to hold the wheel rim flat against the spoking board, use a screwdriver to tighten all the spokes one more complete turn.

It is easier to know when you have tightened all the spokes if you begin tightening them on one side of the valve hole, then tighten them all the way around the wheel, and stop when you reach the other side of the valve hole.

17) Stretch the spokes by grasping two at a time and squeezing them hard. Then tighten each spoke an additional 1/2 turn. Repeat this stretching and tightening process until most of the spokes have begun to tighten up.



Candice Stein of California

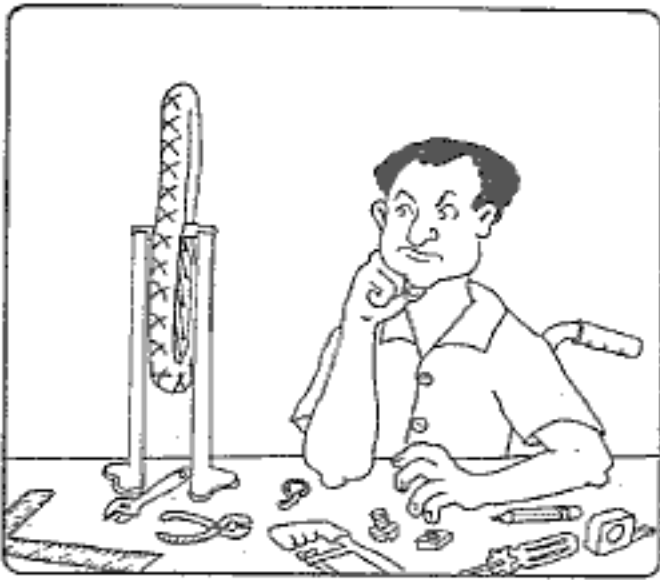

## TRUING THE WHEEL

Once the wheel is completely spoked, the challenge begins. By tightening and loosening selected spokes you can usually make the wheel perfectly round, the rim flat, and the spokes uniformly tight. Each spoke should be tightened only a little bit at a time. Be careful not to tighten the spokes too much. We've seen wheels that collapsed because the spokes were tightened too far before the wheel was true.

### DIRECTIONS

1) Set up a truing stand. You can use an old bicycle fork with two nuts welded on. Bolts screwed into the nuts will serve as reference points when trying to judge how far out of alignment the wheel is (see diagram). Secure the bicycle fork in a vise.

2) Spin the wheel on the truing stand. Using the bolt as a reference point, notice when the rim moves out away from the hub and when it moves toward the hub. Tighten the spokes along the parts of the rim that move away from the hub. Remember to tighten the spokes at the edges of the bulge less than those in the middle. Keep tightening the spokes until the wheel is round. If the wheel gets too tight during this process, loosen the spokes around the wheel that are pulling the rim toward the hub. The spokes should only be moderately tight when this step is completed.

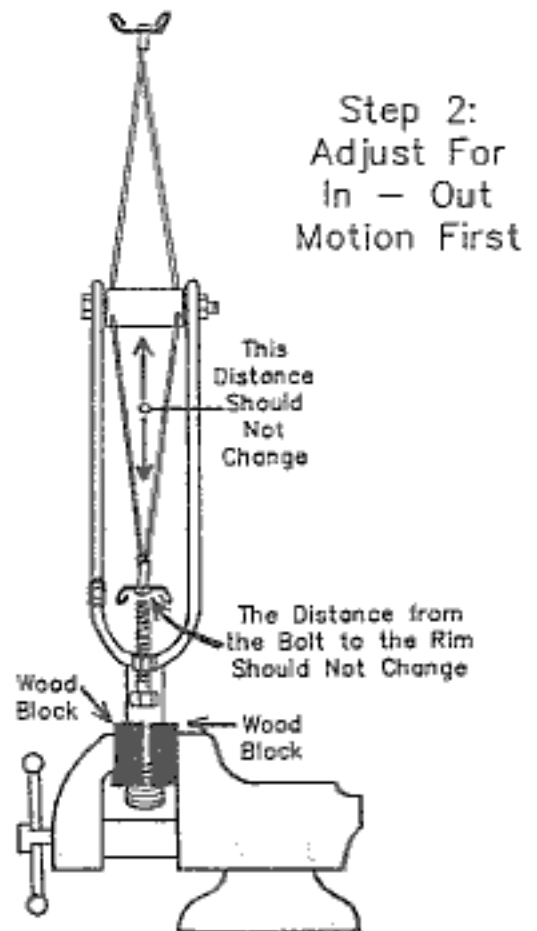

3) As a spoke becomes taut, the friction between the spoke threads and the nipple increases. If the friction is too great when the nipple is turned to tighten the spoke, the whole spoke can twist rather than becoming tighter as was intended. Stressing the wheel will put added tension on some spokes and it will allow some spokes to loosen and untwist. To stress the wheel, remove it from the truing stand, lay it on a flat surface, and press down with both hands on opposite sides of the rim (the hub will support it in the middle). As the spokes unwind you may hear some creaking sounds. Rotate the wheel slightly and press again. Repeat the process all the way around the wheel until you don't hear or feel the spokes unwinding. Turn the wheel over and repeat the stressing and turning on the other side until you can't hear or feel the spokes unwinding. Once all the spokes have been given a chance to untwist, you can tell how tight each spoke actually is.



4) Mount the wheel back on the truing stand. This time, check for side to side motion as the wheel spins. Holding a pen or piece of chalk next to the wheel may help you to find the bulges. The chalk will leave a mark on the rim on the spots that bulge out. Where the wheel bulges to one side, tighten the spokes that will pull it to the other side. Remember to tighten the spokes on the ends of the bulge less than those in the middle.

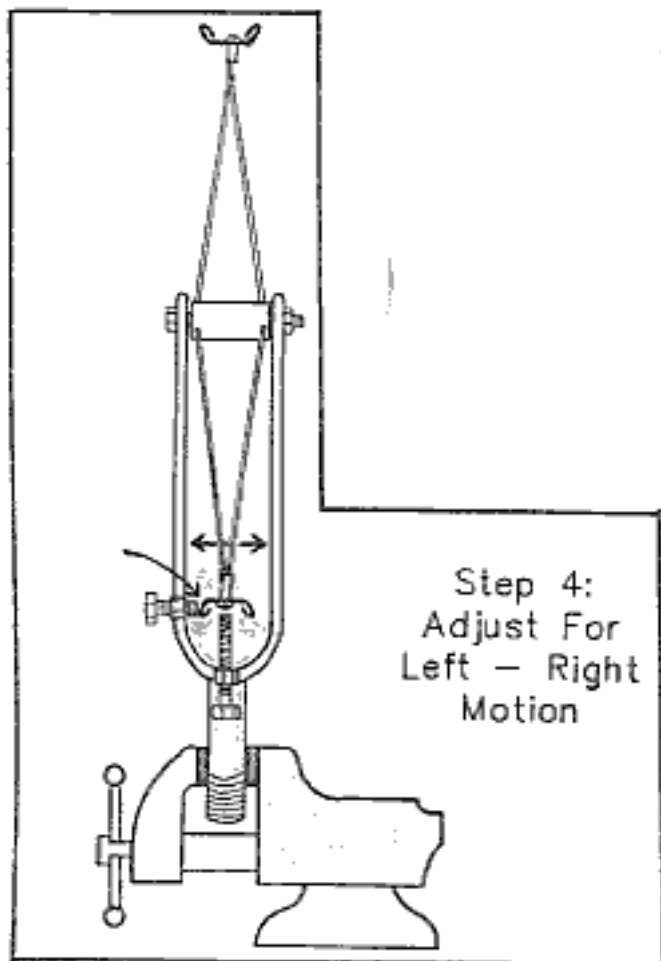

It is difficult to separate steps 2 and 4 above. Whenever you tighten a spoke it will affect both the side to side and up and down alignment of the wheel; consequently, it is important to work with the wheel as a whole.

5) Continue to make adjustments on the wheel, until all of the spokes are fairly tight. Once the wheel looks like it is round and doesn't wobble from side to side, remove it from the truing stand and repeat the stressing and turning procedure on both sides of the wheel. Place the wheel back on the truing stand and make final adjustments.

6) Finish this project by tightening each spoke another 1/2 turn (unless the spokes are already very tight).

## ADDING THE HANDRIMS

Once the wheels have been built and trued, the next step is to attach the handrims. The easiest method of attaching a handrim to a wheel uses brackets made out of short pieces of flat steel bar. There are two different styles of brackets that will work well. One style is best for a handrim that is almost as large as the wheel, the other is used for a handrim that is smaller than the wheel.

Connect the handrim to the wheelrim in four points equally spaced around the wheel. If the wheel rim has 36 spoke holes, three connecting points are preferable; it will save you some work and will result in a lighter wheel. The illustrations show the two different methods of using brackets made of steel bar to connect the handrim to the wheel.

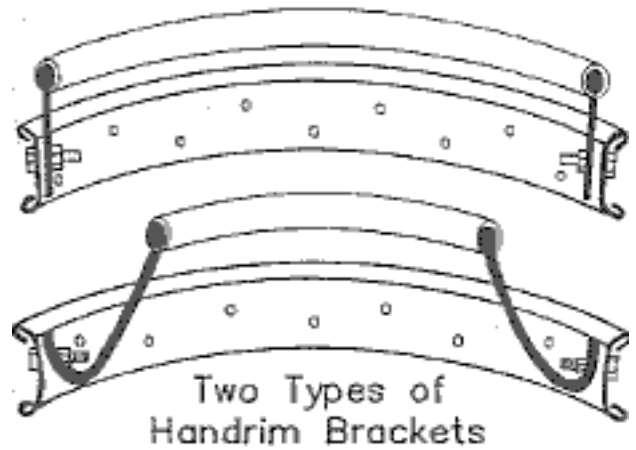

## MATERIALS FOR ADDING THE HANDRIMS TO THE WHEELS

ITEM	SIZE	QUANTITY
1/8" x 1/2" (2 or 3 mm x 10 mm) flat steel bar	3" (7.6 cm) long	6 or 8 pieces
3/16" (5 mm) bolts	5/8" (16 mm) long	6 or 8
Lock Washers	3/16" (5 mm) I.D.	6 or 8
Nuts	3/16" (5 mm) I.D.	6 or 8
Handrims (bent in Chapter 8)	(see Chapter 4)	2
Spoked Wheelrims	(see Chapter 4)	2

## JIGS FOR ATTACHING THE HANDRIMS TO THE WHEELS

- Handrim Drilling Jig

This jig is an adapted spoking board. Directions for making one can be found in Appendix B; it can also be purchased as part of the Basic Tool Kit.

## DIRECTIONS

The directions that follow describe how to mount an 18" diameter handrim on a 24" x 1- 3/8" wheelrim using method B. If the handrim is nearly the same diameter as the inside of the wheelrim, use straight pieces of bar for the handrim brackets.

1) Cut 1/8" x 1/2" (2 or 3 mm x 10 mm) flat steel bar into three or four 3" pieces (three or four pieces if your wheel rims have 36 holes, four pieces for all others).

2) Scribe a line 1/4" (6 mm) from one end of a piece of bar. Center and drill a 7/32" (6 mm) hole on the line. Use this piece as a jig to drill identical holes in the other pieces of bar.

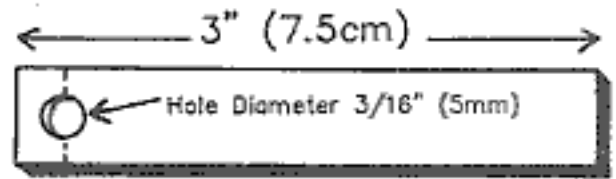

Handrim Bracket Dimensions

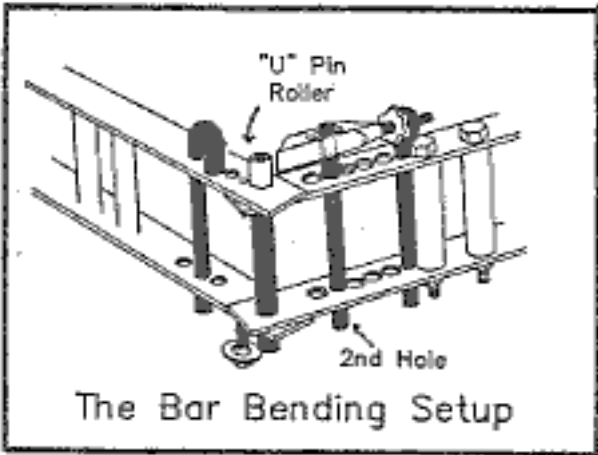

3) Set up the Hossfeld type bender to bend bar. Mount the "U" Pin Roller on the center pin. It will serve as the bending die. (A detailed description of how to set up the bender to bend bar can be found in Chapter 6).

4) Start the bend as close to the hole as possible. Using the drawing as a sample, bend the bar to the correct shape. It will probably take a bit of trial and error to get just the right bend.

5) Place the wheelrim in the rim drilling jig and drill four 7/32" (6 mm) evenly spaced holes. (Drill three or four holes if you are using a 36 spoke wheelrim.) If you are not using a jig, please note that the holes are not drilled in the middle of the rim, but are drilled closer to the outside edge.

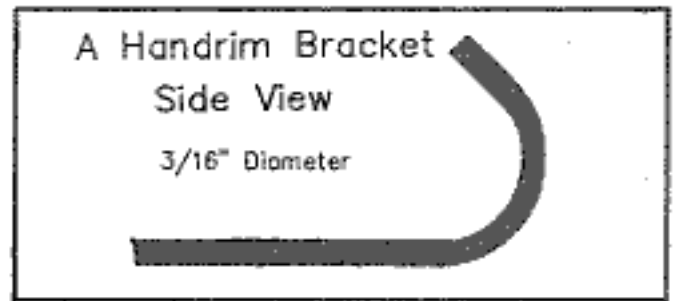

6) Bolt each handrim bracket to the wheelrim using 3/16" (5 mm) diameter bolts and lock nuts (or lock washers). The bolts should be 5/8" (16 mm) long.

7) Balance the handrim on top of the handrim brackets. Check to be sure that the handrim is level in all directions and that the brackets are centered under the handrim. If the handrim isn't level, or if the brackets are not centered, bend the handrim brackets until the problem is corrected. The brackets must be centered under the handrim or there will not be enough clearance for the rider's fingers.

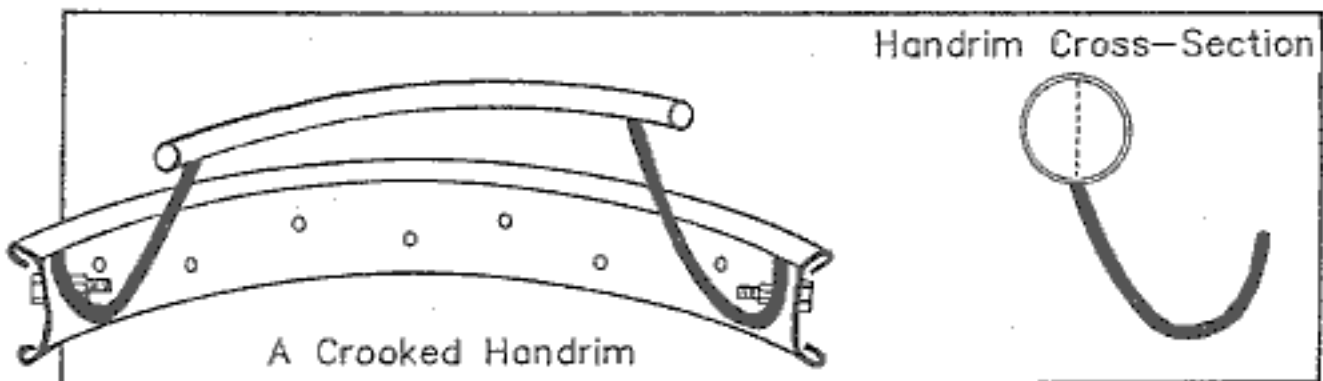

8) Weld the handrim to the handrim brackets with a steel or brass welding rod. Since the handrims will not be painted or plated, the welds must be filed so that the discolored metal is not too obvious.

9) Wax the handrims to prevent them from getting rusty before they are sold. Plating the handrims should not be necessary if they are to be used on a daily basis; oil from the rider's hands usually protects the handrims from rust. If the handrims are plated with chrome, the plating often peels and can cut the rider's hands badly. Because of this problem we prefer less expensive nickel plating.

## **ADDING THE TIRES AND ATTACHING THE WHEELS TO THE FRAME**

1) Check to be sure that none of the spoke ends are protruding past the heads of the nipples. If any do, cut and file them until they are flush with the nipples.

2) Put a rubber rim strip on each rim. These can often be purchased from a bicycle parts dealer. If you can't find any you can make your own out of a strip of old inner tube.

3) Put the inner tubes and tires onto the rims. Inflate the tires to about 20 pounds of pressure. Check both sides of the wheel to be sure that the tire is seated all the way into the rim. Then inflate the tire to its rated pressure.

4) Using the axle bolts, attach the wheels to the frame through the axle socket. Use locknuts or nuts that you have made into locknuts (a description of how to do this can be found in Chapter 6). The nuts should be very tight.

5) Spin the wheels to make sure they are true and spin freely without too much friction.

[Table of Contents](#)

# Center for International Rehabilitation

## Chapter 12 Making the Front Wheels



Ralf Hatchkiss of California

While the rear wheels are fixed to the frame in one position, the front wheels pivot on a bolt and allow the rider to steer the chair. The pivoting front wheel is called a caster. Each caster is made up of two main parts, the wheel and the caster fork assembly.

Our wheel is made of two hardwood discs. Each disc is indented to hold a sealed ball bearing, with one bearing on each side of the wheel. Extra-wide solid rubber or pneumatic tires can be used with the wooden wheels.

Each caster fork assembly includes a caster barrel which is welded to the frame. The caster barrel encases the bearings and the pivot bolt. The pivot bolt is welded to the arms of the caster fork which, in turn, support the wheel axle.

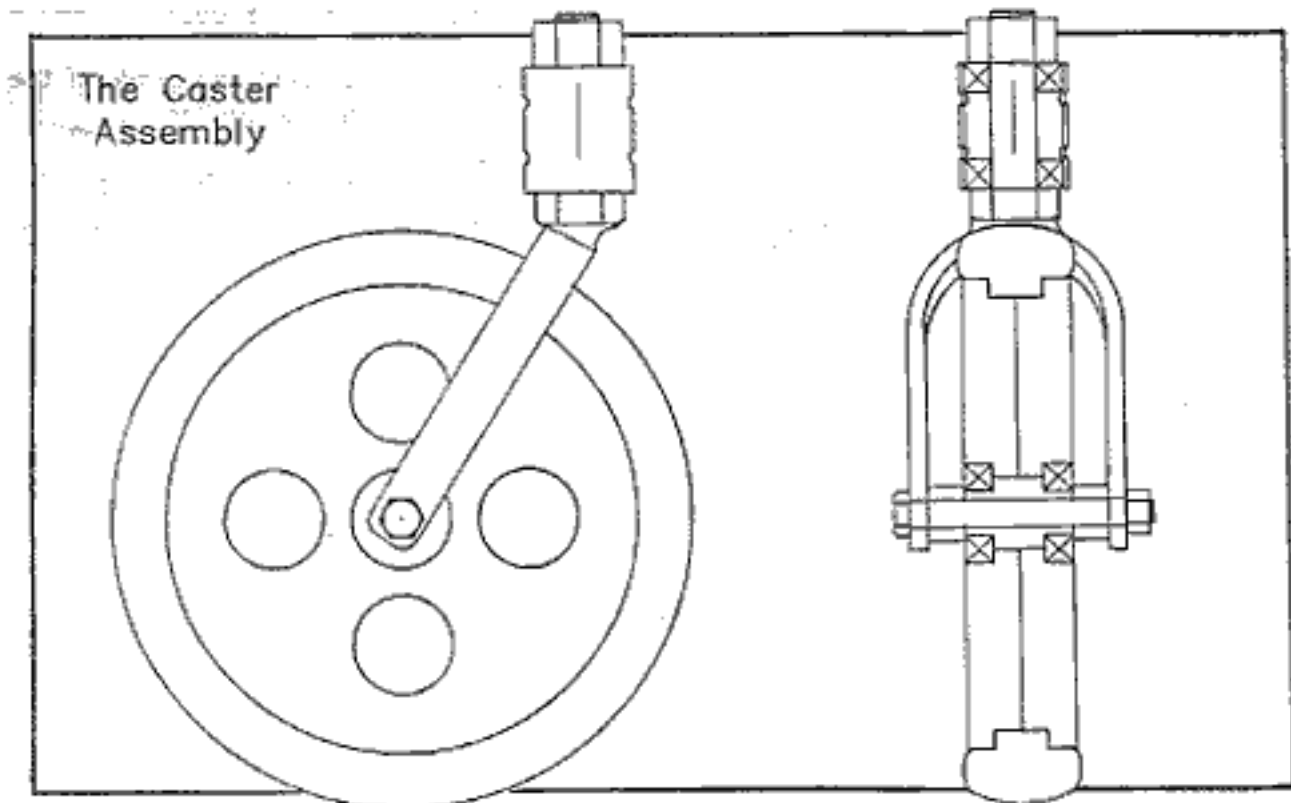



## CASTER WHEEL DESIGN

If the front wheels are too small, the chair will have difficulty traveling over rough ground. If they are too big, they may bump into the back wheels and the footrests when they swivel. Lengthening the frame to accommodate larger front wheels is possible, but this makes the chair longer and thus much more difficult to maneuver. Most wheelchair riders have found that a wheel with a 7" to 9" (18 cm to 23 cm) diameter is a good compromise -- small enough to fit the frame, and large enough not to get stuck in rough terrain.

The front wheels must be strong enough to bump into curbs and hit potholes without breaking. While the front wheels must be sturdy, they must also be light. The heavier they are, the more likely they are to flutter from side to side when the chair is moving quickly. Fluttering front wheels can slow the chair so suddenly that the rider is spilled to the ground.

Consequence of a Weak Front Caster

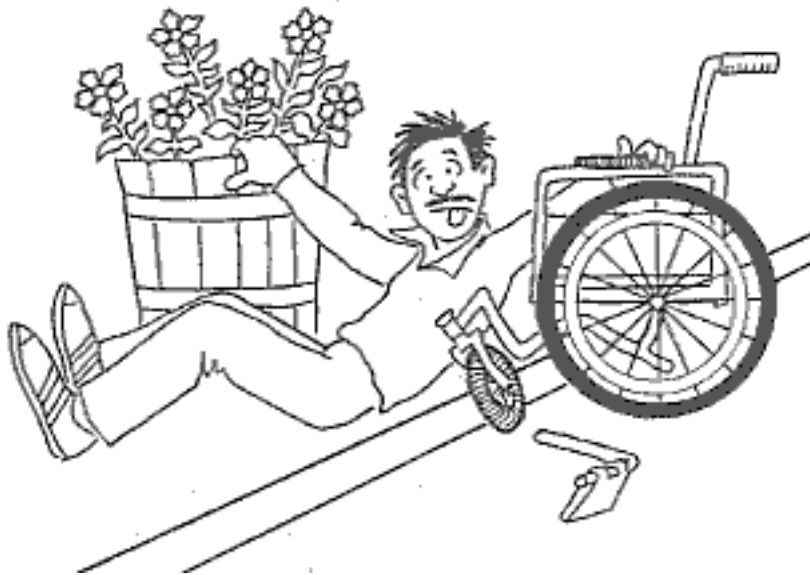

Finally, the front wheels must be inexpensive and easy to make. Many wheelchair makers have been making front wheels out of metal hubs and rims with short pieces of heavy duty spokes welded in between. While these wheels are strong, lightweight and are made from inexpensive materials, they can take a long time to make, and thus are too costly.

Our current design of wheel is made of two hardwood disks bolted together to hold either a pneumatic or solid rubber tire. While there is still room for improvement, the hardwood wheels are inexpensive, lightweight, sturdy, and fairly easy to make.

Good front wheels can also be sand cast of aluminum. Take a sample of a commercial aluminum wheel to a casting shop. They will make a mold around the sample, remove it, and pour in molten aluminum to mold a new wheel. It is usually necessary to have the holes for the bearings machined on a lathe to prevent the wheel from wobbling.

# TIRES

It is important that the front tires have some flexibility. A chair with hard tires is uncomfortable to ride and difficult to push. In addition, a chair with hard tires will not last as long. Pneumatic tires have many advantages. They cushion the ride much better than a solid rubber tire, and they provide so little resistance to the forward motion of the chair that they will almost float over gritty pavement. Pneumatic tires are also very light. This is important because any extra weight in the outer part of the wheel will contribute to caster flutter. On the other hand, pneumatic tires will need to be pumped up regularly, patched occasionally, and replaced more often than solid rubber tires.

At this writing the 8" x 1-1/4" and 8" x 2" tires and tubes are not available in many countries. They can be ordered in quantities of several hundred or more for about U.S.\$2.50 per tire and tube (1983 price) from:

Mady Enterprise Co., Ltd.  
4th Fl. Ming Yen Building  
No. 512 Sec 4. Chung Hsiao  
E. Rd. Tapei, Taiwan  
Republic of China  
  
Telephone # (02) 703-0282-5

Import duties, broker's fees, and shipping costs are additional.

If you wish to use solid rubber tires, you can have them made locally by a rubber molding company. First hire a skilled machinist who specializes in making molds for rubber to make your molds. The cost of making the mold for the rubber tires has varied from about U.S.\$300 to U.S.\$500. Then find a rubber molding company that can mold the tires using a high latex content rubber of about 55 durometer (durometer is a measure of rubber hardness). A hardness rating of 55 durometer is very important because the harder rubber (65-80 durometer) that is used on most chairs gives a rough ride and is harder to push over rough roads and the softer rubber (30-40 durometer) used in the Philippines wears out fairly quickly. The cost of molding good tires has varied from about U.S.\$1.50 in Peru and Honduras to U.S.\$4.00 in Costa Rica.

The dimensions of the standard solid rubber tires that are made in several American countries are about 5-7/8" (14.9 cm) inside diameter, 7-7/8" (20 cm) outside diameter, and 1" (2.5 cm) wide. We prefer tires which are molded 1-1/2" (3.8 cm) wide (see the diagram at the beginning of this chapter) because they roll more easily over rough ground and they protect the wooden wheel. See page 147 for a tire mold design.

8" x 1-1/4" pneumatic tires use a smaller wheel than is needed for the common size of solid tires described above. If a solid tire is needed to fit the same wheel as the pneumatic tire, the solid tire should have a 5-1/4" (13.3 cm) I.D. and a 7-1/2" (19 cm) O.D. When mounted, solid tires will stretch to a slightly larger diameter.

# MAKING HARDWOOD FRONT WHEELS

## MATERIALS:

ITEM	QUANTITY	PART OF CHAIR
3/4" (18 or 20 cm) hardwood or marine plywood	7" x 28" (17.8 cm x 71 cm)	Wheel Disks
5/16" (8 mm) bolts with nuts	2 bolts, 3-1/2" (9 cm) long 4 nuts	Axle Bolt
1-3/8" O.D., 5/8" I.D. bearings*	4	Wheel Bearings
3/8" hexnut	4	Bearing Spacers
3/16" (5 mm) bolts and nuts washers (5/16" I.D.)	8 sets; bolts 2" (5 cm) long 12	Wheel Disk Bolts Spacers

\* See bearing chart on page 79 for bearing numbers and other bearing sizes that work.

## DIRECTIONS

Each wheel is made of two wooden disks. The inner edge of each disk is slightly smaller, creating a channel to hold the tire.

The following directions are for making the hardwood disks for the 6" I.D. x 8" O.D. solid rubber tires. Smaller disks of the same design will work for pneumatic tires.

1) To make the wheel disks, cut the 3/4" (18 or 20 mm) hardwood into 4' x 7" (122 cm x 17.8 cm) pieces.

2) On top of a scrap piece of plywood, clamp one of the hardwood pieces onto the drill press table. This will hold the hardwood flat and level while you cut out the circle.

3) Using the circle cutter, cut four 6" (15.2 cm) diameter circles. **ONLY CUT HALFWAY THROUGH THE HARDWOOD!**

**BE CAREFUL WHILE USING THE CIRCLE CUTTER; IT CAN EASILY CUT OFF STRAY FINGERS!**

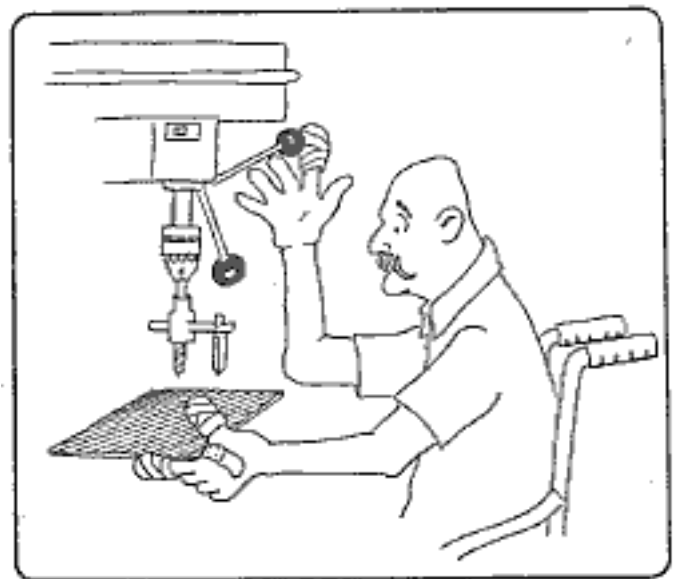

4) Turn the hardwood over, and clamp it to the drill press table. Using the same center holes to guide the circle cutter, cut four 6-1/2" (16.5 cm) diameter circles in the same location (but from the other side) as the holes above. (See diagram.)

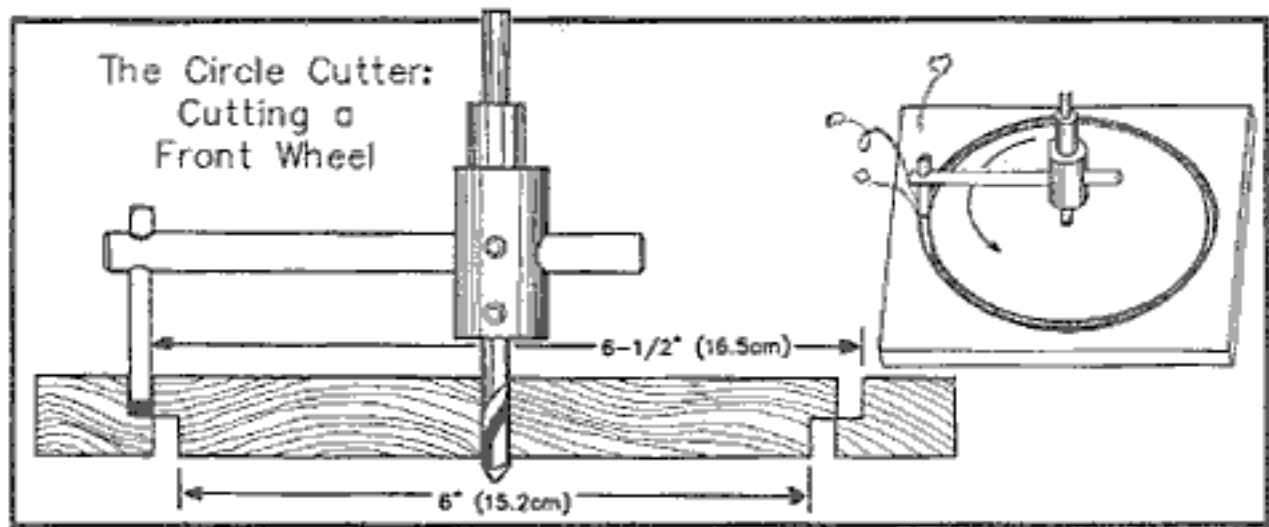

5) For each wheel, bolt two disks together as in the drawing by inserting a 1/4" (6 mm) diameter bolt through the holes that were left by the circle cutter in the center of each disk. Tighten the bolt to hold the disks together. Then drill four 3/16" (5 mm) holes as shown. Note that one of these holes is closer to the center of the wheel than the other holes. This ensures that the two halves of the wheel can only be assembled the same way they were drilled. If they were put back together differently, the wheel might wobble. Put a number on each disk to prevent them from being mixed up with disks from other wheels.

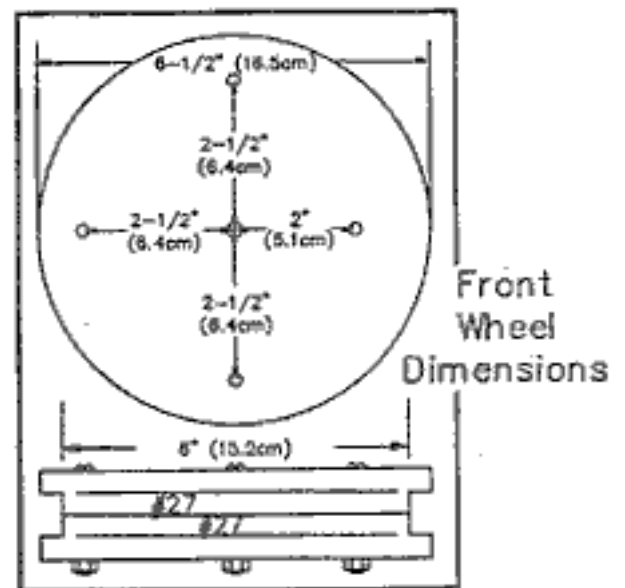

6) Insert and tighten four 3/16" x 2" (5 mm x 5 cm) bolts as shown. Remove the 1/4" (6 mm) bolt from the center of the wheel.

7) Using the circle cutter, cut some sample 1-3/8" holes in scraps of hardwood. Insert a 1-3/8" O.D. bearing and see how it fits. If it doesn't fit tightly, adjust the diameter of the circle cutter until the bearing fits very tightly.

8) Once the circle cutter is properly adjusted, starting on the outside of each disk, cut a 1-3/8" hole half way through the center of both disks. If you want to lighten the wheel, cut four more 1-3/8" diameter holes all the way through both disks in an evenly spaced pattern around the wheel.

9) Cut 1" (2.5 cm) holes all the way through the centers of both disks.

10) If you are using 1-3/8" O.D. by 5/8" I.D. bearings or #6202 bearings with an inside diameter of 16mm in your front wheels, press a 3/8" hexnut into the middle of each bearing with a vise. The 3/8" nut will serve as a spacer between the bearing and a 5/16" (8mm) diameter axle bolt.

If your wheels are using #6202 bearings with an inside diameter of 15mm, you will have to grind or turn a 3/8" nut or a piece of hardwood, steel, or other solid material to the right size. Unfortunately, there is no standard size nut that will fit tightly in a 15mm hole.

11) The wheels are now ready for sanding, painting, and final assembly. When the paint is dry, assemble the wheel around a solid tire and hammer the bearings carefully into place.

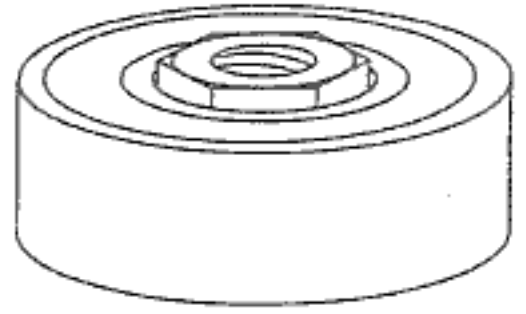

A nut can serve as a bearing spacer.

## CASTER DESIGN

The caster assembly allows the front wheel to swivel so it will go in the direction you push it. Each caster includes a caster barrel welded to the wheelchair frame, bearings, and a caster fork (a pivot bolt welded to arms bent out of solid bar).

## CASTER FORK FAILURE

Caster forks made by some of the larger wheelchair companies are easily broken or bent when the wheelchair runs into a rock or curb. A caster fork that has been bent can cause the wheelchair to swerve crazily to one side or to stop suddenly, dumping the rider to the ground. Wheelchairs with bent caster forks are a common sight in wheelchair repair shops.

When any wheelchair runs into a curb or chuckhole at a fast walking pace, its fork can be pushed back with over 300 pounds (136 kg) of force. Many commercial forks fail when subjected to impacts of less than 200 pounds (91 kg). The fork we have designed, if it is well made, should withstand impact forces of over 400 pounds (182 kg).

When a fork does fail, it is safer if the fork fails by bending rather than fracturing. If a pivot bolt of 1/2" (13 mm) diameter or less is used, it must be made of hardened steel to prevent bending. Using a hardened steel bolt can be risky - if the bolt is a little too hard, it will break before it bends. Our caster fork design uses larger 5/8" (16 mm) pivot bolts made out of mild steel. They are safer and less expensive.

## REDUCING CASTER FLUTTER

Whenever a wheelchair with a front caster of typical design is moving at a fast walking pace, its caster can begin to flutter or vibrate violently. This vibration can slow a chair down so suddenly that the chair tips forward, dumping the rider to the ground. Every time a wheelchair rider pushes at high speed or coasts down a hill, there is a possibility that he or she will suddenly lose control and be seriously injured. The caster fork can be designed to greatly decrease the risk of caster flutter. The easiest way to stop flutter at moderate to high wheelchair speeds is to increase the amount of trail of the caster fork. Caster fork trail is a measure of how far the center of the front wheel trails behind the pivot line of the caster fork. Many commercial chairs use as little as 2" (5.1 cm) of trail; however, the casters on these chairs can flutter severely at moderate speeds. In our opinion, a normal chair needs 2-1/2" (6.3 cm) of trail, and a racing chair needs 3" (7.6 cm) or more.

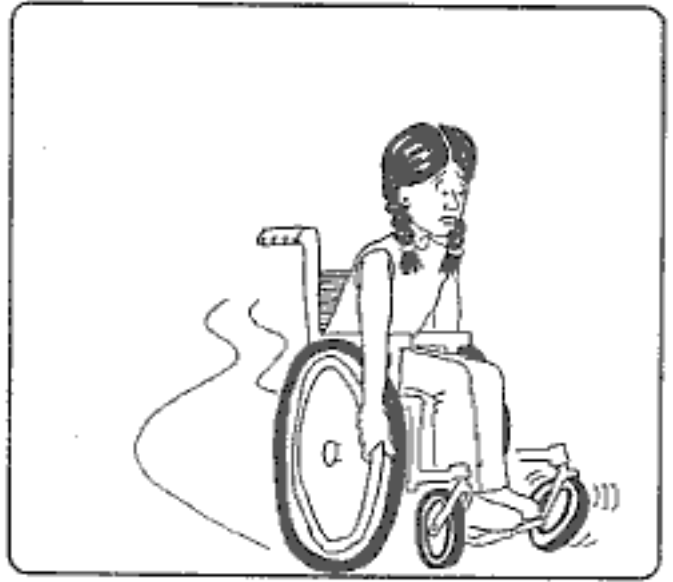

Unfortunately, the more trail the caster fork has, the more space the caster needs in order to swivel. If you give the caster more swivel space by lengthening the frame or extending the footrests, you also make the chair more cumbersome. The Torbellino wheelchair has a caster fork trail of 2-1/2" (6.3 cm). This is long enough to diminish flutter and short enough to fit within the standard size frame.

Caster flutter can be reduced even further by increasing the friction where the pivot bolt swivels. First add a soft leather washer under the nut on the pivot bolt. Then, underneath the bottom bearing, add a 5/8" (16mm) I.D. steel washer with the side next to the bearing slightly indented. Because this washer doesn't touch the inner race of the bearing, the entire weight of the chair presses the outer race of the bearing against the washer and the pivot bolt. This prevents the pivot bolt from swiveling as easily. The friction increases as the weight on the front of the chair increases. Anytime the caster begins to flutter, it slows the chair and shifts weight to the front. This presses the washers against the bearings and stops the flutter.

# MAKING THE CASTER ASSEMBLY

## MATERIALS

ITEM	SIZE	QUANTITY	PART OF CHAIR
1/4" x 3/4" (6mm x 20mm) solid bar	11" (30 cm) long	2	caster forks
5/8" (16mm) O.D. fine thread bolts	2-1/2" (6.4 cm) long	2	pivot bolts
locknuts	5/8" (16mm) fine thread	2	for pivot bolts
5/8" (16mm) I.D. washers	1-3/8" (35mm) O.D.	2	for pivot bolts
bearings*	#99502h(1-3/8"x 5/8")*	4	in caster barrels
casterbarrels		2	caster barrels

(already attached to main sideframe pieces)

\*As in the rear wheels, other bearings with similar dimensions will also work. See chart in Chapter 11, page 79.

## JIGS AND BENDERS FOR MAKING THE CASTER ASSEMBLY

- Hossfeld Type Bender and Caster Fork Die
- Caster Fork Welding Jig

Instructions for making the caster fork bending die and the caster fork welding jig can be found at the end of this chapter. Both can also be purchased ready made as part of the Basic Tool Kit.

## DIRECTIONS

1) Set up the bender to bend bar using the eye pin, flat-head pin, eye bolt bending dog, "U" pin, "U" pin roller, and caster fork die. See Chapter 6 for more detailed instructions on how to set up the bender to bend bar.

2) Cut two 11" (27.9 cm) pieces of 1/4" x 3/4" (6mm x 20mm) solid steel bar and mark each piece 3" (7.6 cm) from one end.

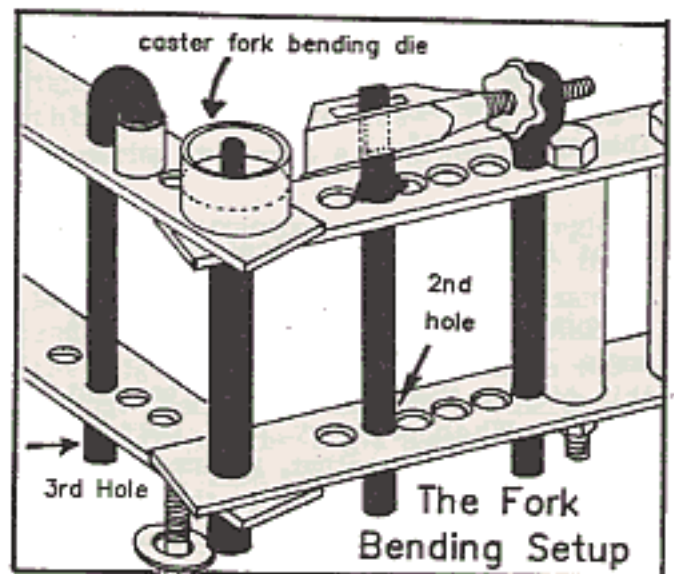



3) Place the bar in the bender. Line up the mark on the bar with the tip of the bending dog.  
4) Bend the bar 180° around the caster fork die until the fork arms are parallel with each other. When you are finished bending, the fork arms should be nearly the same length. It doesn't matter if one is 1/4" (6 mm) longer than the other.

5) Make a mark 3/8" (10 mm) in from the end of the shorter arm, and drill a 5/16" hole for the axle bolt.

6) Place the fork in the drill press vise between two blocks of metal or wood as shown. Make sure that the fork is flat in the vise.

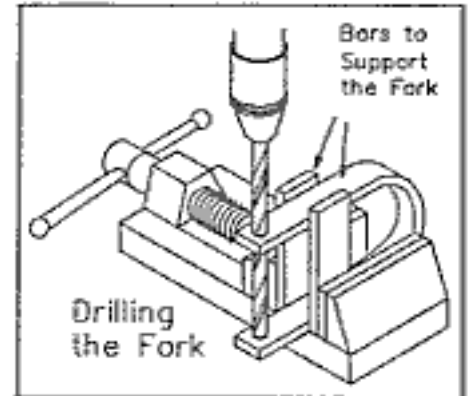

7) Put the drill through the hole in the top arm and drill a hole in the bottom arm. Make sure that the drill is at right angles to the arms of the caster fork.

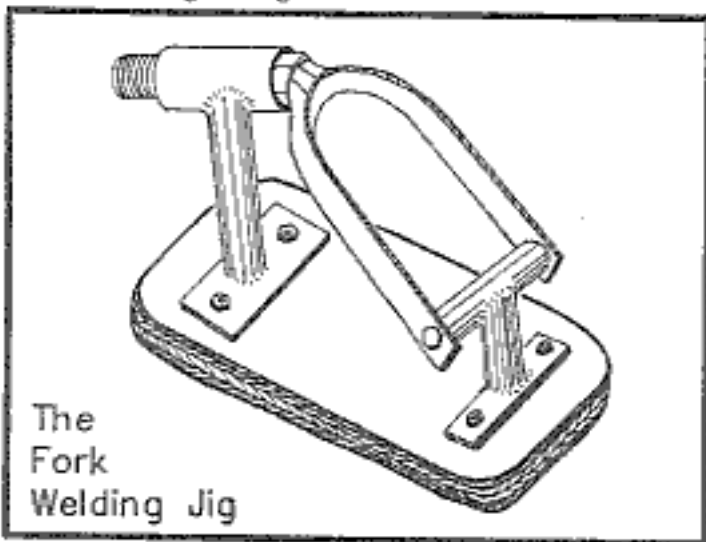

8) Before brazing the pivot bolt to the caster fork arms, be sure to sand, wire brush, or file both parts down to bare metal. The strength of a dirty weld is always unpredictable, even though it may appear well bonded! It is very important to weld the fork securely. If the caster fork arms were to break loose from their pivot bolt, the wheelchair rider could be seriously injured.

9) Place the caster fork and the pivot bolt in the caster fork welding jig as shown. Weld the bolt to the fork using electric arc welding equipment if available. Bronze brazing also works well, but it is more expensive. Let the fork cool slowly so that it does not crack.

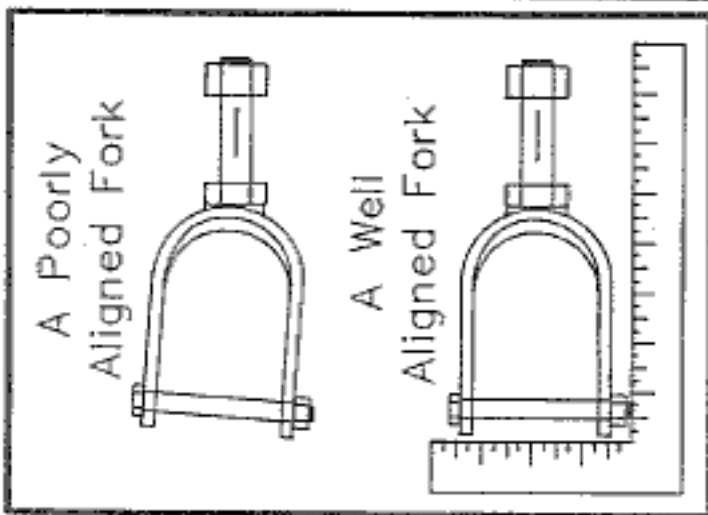

10) Check the finished part for good alignment. Bend it into alignment if necessary. A poorly aligned fork will cause the chair to pull to one side.

11) Before adding the caster forks to the frame, paint or plate them. Since the caster forks will take a lot of abuse, plating is the better method of protection.

## MAKING THE ANTI-FLUTTER WASHERS

1) Make the upper anti-flutter washer by cutting a hole in a piece of leather with a 5/8" (16mm) leather punch. Put this washer under the nut on the caster pivot bolt.

2) If you have a large drill bit (7/8" [22 mm] or larger), make the lower anti-flutter washer by placing a 5/8" (16mm) steel washer in the drill press vise and boring half way through the washer. Be sure to set the drill press at a very slow speed. If your drill press doesn't have a slow speed, turn the drill press by hand.

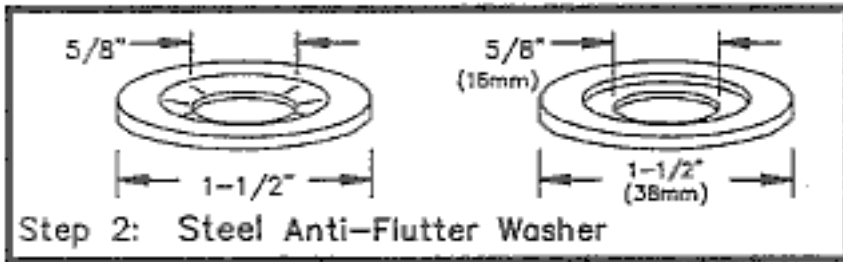

If you don't have access to a large drill bit, make the lower washer by welding a 5/8" (16mm) I.D. washer under a 7/8" (22mm) I.D. (or larger) washer.

## ASSEMBLING THE CASTERS

1) Now that the caster forks and washers have been made, they can be attached to the frame. Slip a bearing into each end of the caster barrel. The indentations will hold them in place; use of a spacer tube is optional.

2) Slide the lower anti-flutter washer onto the pivot bolt. Be sure that the indented side of the washer faces away from the fork.

3) Insert the 5/8" (16mm) pivot bolt into the bearings. Slide a leather washer over the top of the pivot bolt, then gently tighten down the locknut. Chapter 6 describes how to make locknuts.

4) Attach the wheels to the caster forks using axles made from 5/16" (8mm) x 3-1/2" (9cm) bolts with locknuts.

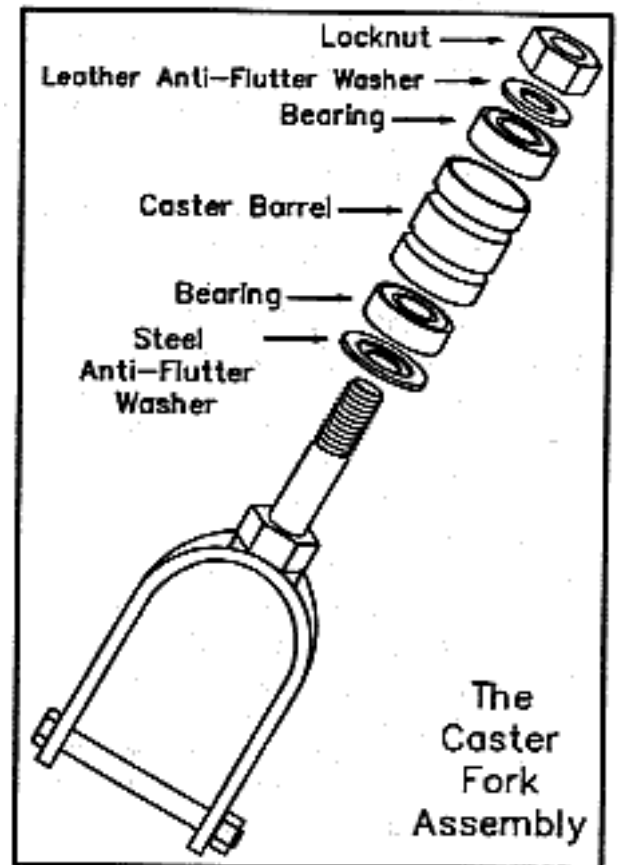

# Center for International Rehabilitation

## Chapter 13 Building the Footrests



A well-designed footrest must serve several functions. It must hold the rider's feet comfortably and securely; it must serve as a bumper, withstanding impact forces of over 300 pounds; and it must either fold out of the way or be completely removable, allowing the rider to maneuver the chair in very tight spaces and to fold the chair up.

Our favorite footrest design is lighter and less complicated than commercial swing away footrests, yet still provides similar advantages. While most folding footrests need two pivots, one to fold the footplate and one to fold the entire footrest, our design needs only a single pivot. Our footrest rotates as it folds, tucking its footplate compactly ahead of the frame of the chair. Because our chair can still be ridden and folded while the footrests are folded, the footrests do not have to be removable.

When unfolded the footrests on the Torbellino angle inward, narrowing the front of the wheelchair. This makes it easier to maneuver the chair in tight spaces.

Each footrest consists of a pivoting tube, an upper tube, a lower tube, and a stop bar. The pivoting tube rotates on the frame of the chair and is welded to the upper tube. The lower tube forms the actual footplate. It slips inside and bolts to the upper tube, adjusting to the length desired by the rider. The stop bar is welded to the pivoting tube. As the pivoting tube rotates, the stop bar hits the caster barrel and keeps the footrest from falling below the proper position. A heel strap connected to the two footrests supports the rider's legs.

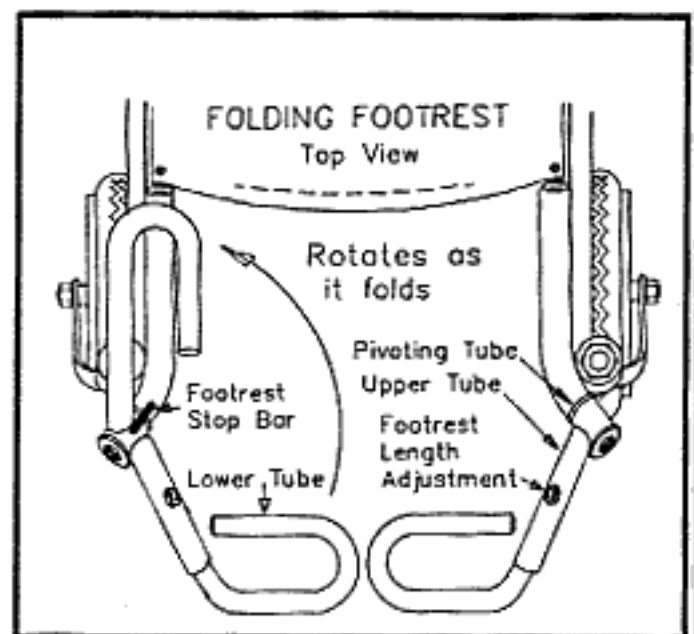

# MATERIALS FOR TUBULAR FOLDING FOOTREST

ITEM	LENGTH	QUANTITY	PART OF CHAIR
3/4" O.D. Tubing*	21" (53.3 cm)	2 pieces	lower footrest
7/8" O.D. Tubing**	5-1/2" (14 cm)	2 pieces	upper footrest
1" O.D. Tubing***	1-3/4" (4.4 cm)	2 pieces	pivoting tubes
5/16" (8 mm) bolts & nuts (fine thread)	1-1/4" (3.2 cm)	4 sets	adjusting and stopper bolts
3/8" (10 mm) round bar	2" (5.1 cm) long	2 pieces	stop bars
2" wide auto seat belt*	24" (61 cm) long	1 piece	heel strap
3/4" O.D. rubber plug	1" (2.5 cm) long	2 pieces	stoppers
Washers	1" O.D.	2 washers	stoppers

\* These lengths are appropriate for a chair with a 16" (40.6 cm) seat width. For every additional inch (2.54 cm) of seat width, add 1/2" (1.3 cm) to the length of each piece of lower footrest tubing. Heel strap lengths will also need to be adjusted accordingly.

1/2" thin wall conduit or 18 mm O.D. tubing can be substituted for the 3/4" tubing.

\*\* 5-1/2" (14 cm) is the standard length for the upper footrest tube. A taller person may need a 7-1/2" (19 cm) upper footrest tube. See Chapter 4 for details.

3/4" thin wall conduit or 22 mm O.D. tubing can be substituted for the 7/8" tubing.

\*\*\* This tubing must swivel snugly on the tubing of the wheelchair frame. Loose fitting tubing can be tightened with the indenting tool. If the only tubing available is much too large, it can be cut and rewelded. Chapter 6 includes descriptions of both of these procedures.

## JIGS AND BENDERS

- Hossfeld Style Tubing Bender (see Chapter 2)
- Pivoting Tube Welding Jig
- Stop Bar Welding Jig
- Upper Footrest Drilling Jig
- Lower Footrest Drilling Jig

Directions for making the jigs are found in Appendix B. The jigs can also be purchased as part of The Basic Tool Kit.

## DIRECTIONS: LOWER FOOTREST TUBE

1) Measure and mark the bends on the two pieces of 3/4" tubing (or the 1/2" conduit or 18 mm tube). They will be bent into the lower footrest tubes. The following measurements are for a standard size footrest. For chairs wider than 16" (40.6 cm), add 1/2" (1.3 cm) where shown for every additional inch (2.54 cm) of seat width.

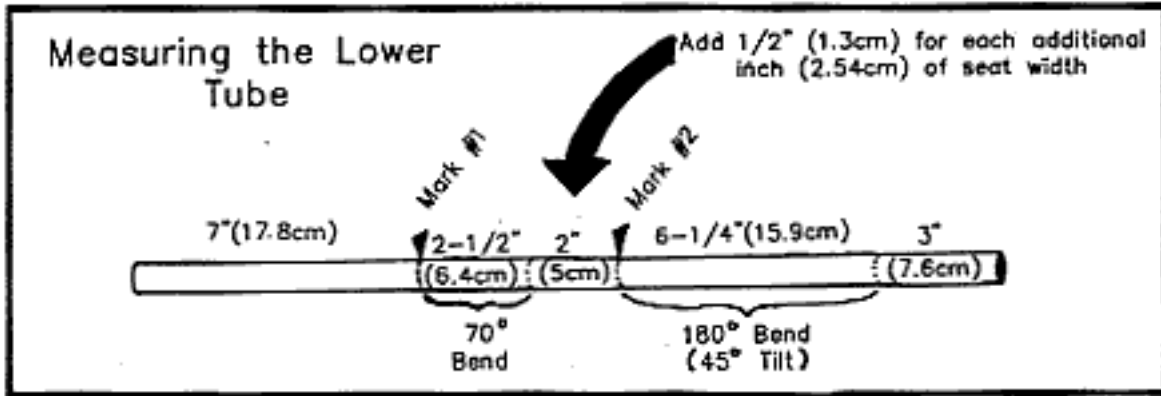

2) Set up the Hossfeld style bender to bend tubing using the die set for 3/4" O.D. tubing with a 1-7/8" bending radius. Chapter 6 includes a complete description of how to set up the bender and bend tubing.

3) Line up Mark #1 on the tubing with the positioning mark on the form die. Clamp the vise grips onto the tubing right next to the back block. If you forget to put the vise grips on you are likely to kink the tubing!

4) Bend the tubing to a 110~ angle. Check the accuracy of the bend with the angle measuring tool and compare it to the sample footrest in the Basic Tool Kit.

5) Repeat steps 3 and 4 with the second piece of tubing.

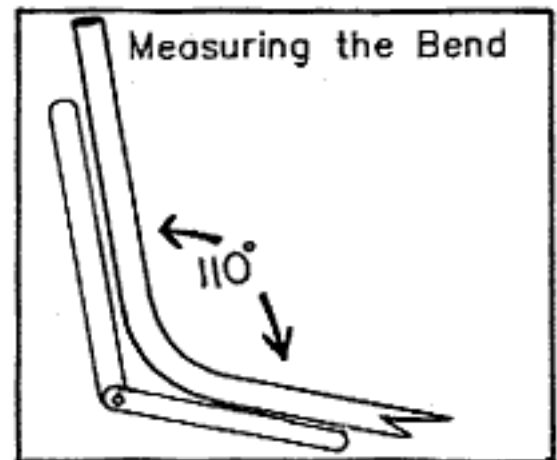
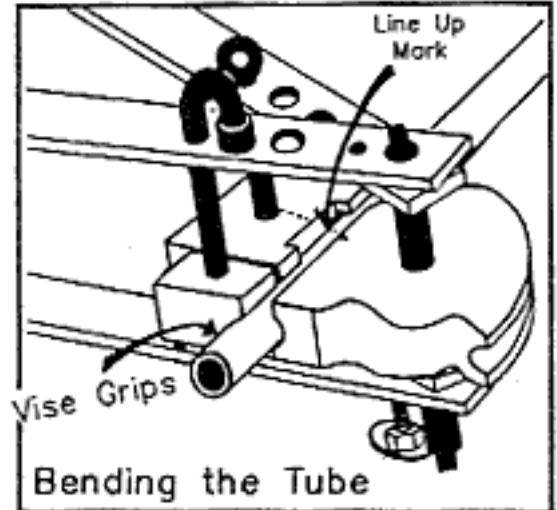

6) To make the left footrest, line up mark #2 with the positioning mark on the form die. Position a protractor on the form die as shown. Rotate the tubing in the bender and site along the protractor until the first bend is positioned at a 45~ angle up from the plane of the bender. Clamp the vise grips onto the tubing right next to the back block.

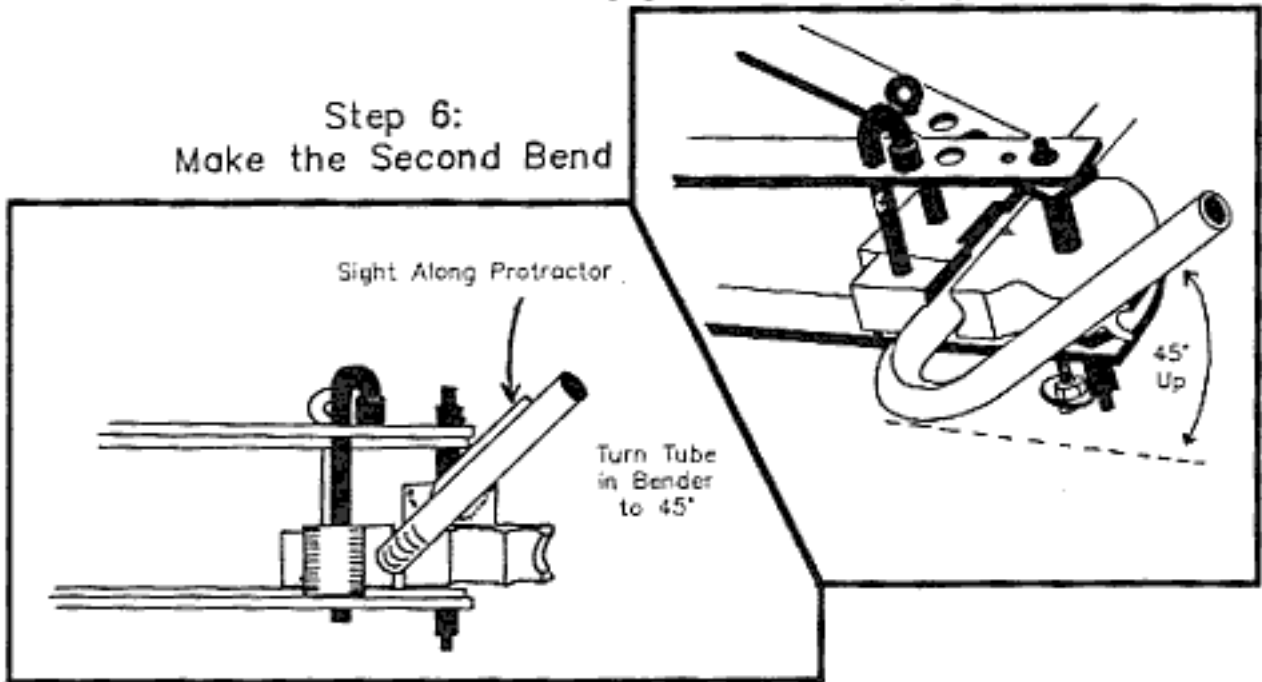

7) Bend the tubing 180~. If the tubing was properly tilted in the bender, the footplate (the 180~ bend) will be tilted back 45~ from the angle of the upper part of the tube.

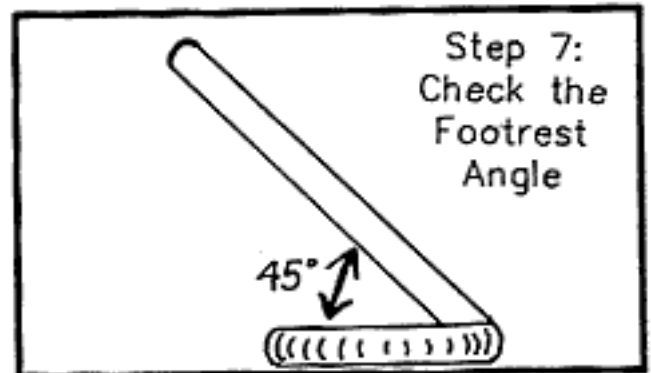

8) Make the right footrest tube by lining up mark #2 with the positioning mark on the form die, and by rotating the tubing in the bender until the first bend is 45~ down from the plane of the bender. Clamp the visegrips onto the tubing right next to the back block, and bend the tubing 180~. Check it with the angle measuring tool.

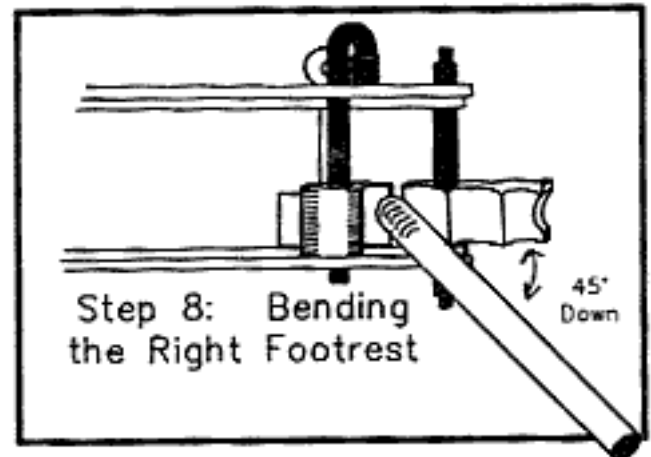

Note: For customers who prefer a different angle for the footplate, simply rotate the tubing in the bender to the angle you want.

9) The exposed ends of the lower footrest tubes can be quite sharp. To protect the rider from injury, weld a rounded washer onto the lower end of each lower footrest tube. To make a rounded washer, place a 3/4" O.D. washer on top of a large nut. Place the rounded end of a ball peen hammer on the center of the washer. Hit the ball peen hammer with a soft mallet. Weld the washer on the end of the footrest tube with its rounded side outward.



10) Use the lower footrest drilling jig to drill three 5/16" (8 mm) holes in each lower footrest tube. Position the jig so that it is flush with the top edge of the lower footrest tube. Put the jig and footrest tube in the drill press vise. Sight along the leveling bar of the jig to make sure that it is parallel to the footplate. The leveling bar may need to be bent to change the angle of the footplate. Drill three 5/16" (8mm) holes. The first hole is located approximately 3/4" (1.9 cm) from the top end of the lower footrest tube. All three holes should be 1" (2.54 cm) apart.

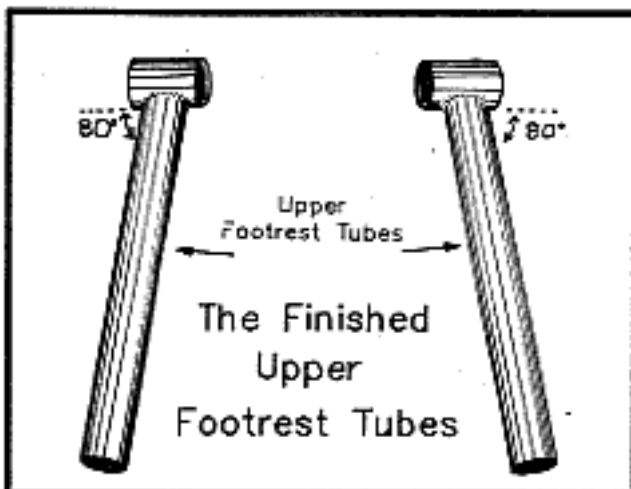
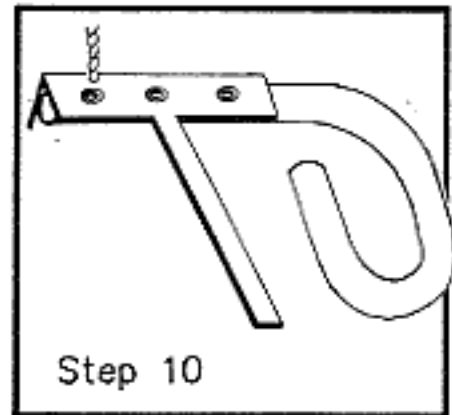
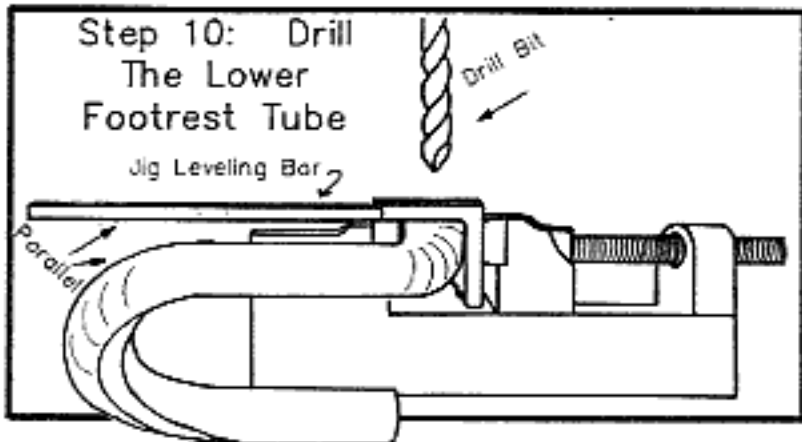

## DIRECTIONS: UPPER FOOTREST TUBES

- 1) Cut two 5-1/2" (14 cm) lengths of 7/8" O.D. tubing for the upper footrest tubes (standard size).
- 2) Cut two 1-1/2" (3.8 cm) lengths of 1" O.D. tubing for the pivoting tubes.
- 3) Using an 8" long, half-round file, shape the top end of each length of 7/8" tubing until it fits against a pivoting tube at an 80~ angle.



The Footrest Welding Jig

4) Hold the tubes in place with the pivoting tube welding jig and braze them together.

5) Use the upper footrest drilling jig to drill one 5/16" (8 mm) hole in the upper footrest tube. Position the jig as shown in the diagram, secure it in the drill press vise and drill.

If you are using a regular length upper footrest tube, slide the jig as far up on the upper footrest tube as it will go. For both the regular and long length upper footrest tubes, the center of the hole should be 2-1/2" (6.4 cm) from the tube's bottom edge.

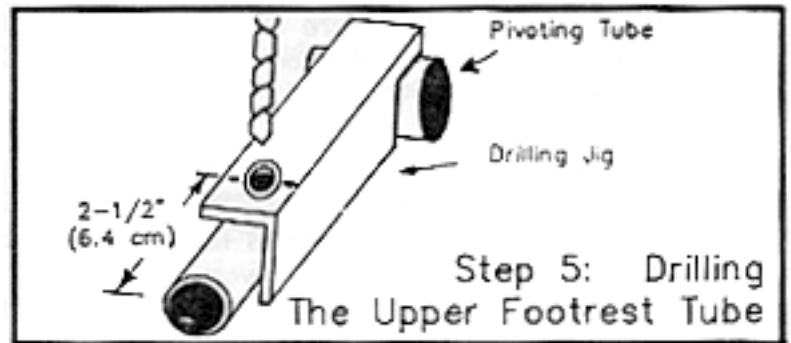

6) To make the stop bars, cut two 2" (5 cm) lengths of 3/8" (10 mm) steel rod.

7) Slip the brake stop welding jig into the pivoting tube on the side where it meets the upper footrest tube at a 100~ angle as shown.

8) Insert a 3/8" (10 mm) stop bar into the square tube of the stop bar welding jig as shown. Push the tube in until the end is flush with the end of the welding jig.



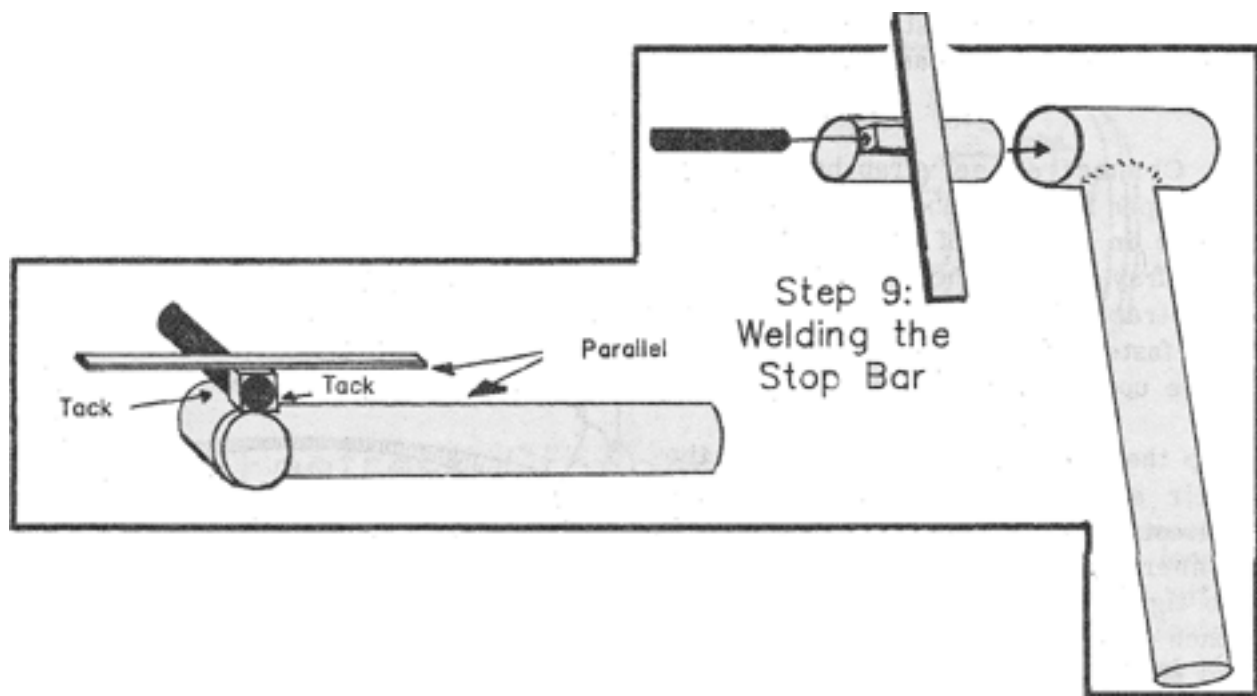

9) Before brazing the stop bar to the pivoting tube, sight along the leveling bar on the stop bar welding jig to make sure that it is parallel to the upper footrest tube. The leveling bar may need to be bent up or down until a good angle for the stop bar is found.

10) Tack the stop bar to the pivoting tube, remove the jig, and finish the weld.

11) Bend two rings of 1/8" (3mm) steel wire around the ends of the pivot tube. Braze the rings in place to reinforce the pivot tubes.

12) File and sand the lower end of the upper footrest tube until it is well rounded. Even though this end is not fully exposed, it can still cut a rider's foot badly.

## ASSEMBLING THE FOOTRESTS

1) Slip the lower footrest tubes inside the upper footrest tubes, adjust them to the desired length, and bolt the footrests together.

2) Put the footrests on a wheelchair by slipping the pivoting tubes over the ends of the sideframe pieces. Make sure that when the front wheels pivot they don't hit the footrests. Check to see if the footrests fold correctly. When folded, they should tuck in close to the seat.

3) If a footrest doesn't open or fold to the correct positions, try to correct it by bending the stop bar (using heat) or by turning the lower footplate. If the footplate needs to be turned, drill extra holes in the top of the lower footrest tube until it is mounted at the right angle. Don't worry if you ruin some trial footrests - - just get them to fold well, then save them as examples. Once a footrest works well, bend the leveling bars on the welding and the drilling jigs so that you can copy that footrest.

4) Once you have made a pair of well aligned footrests, remove them from the chair, take out the adjusting bolt, and plate or paint them. If you can afford limited plating, plate the lower footrest tubes; they will be subjected to a great deal of wear. If you paint, remember to clean the metal thoroughly (sand and use a metal conditioner). See Chapter 5 for painting details.

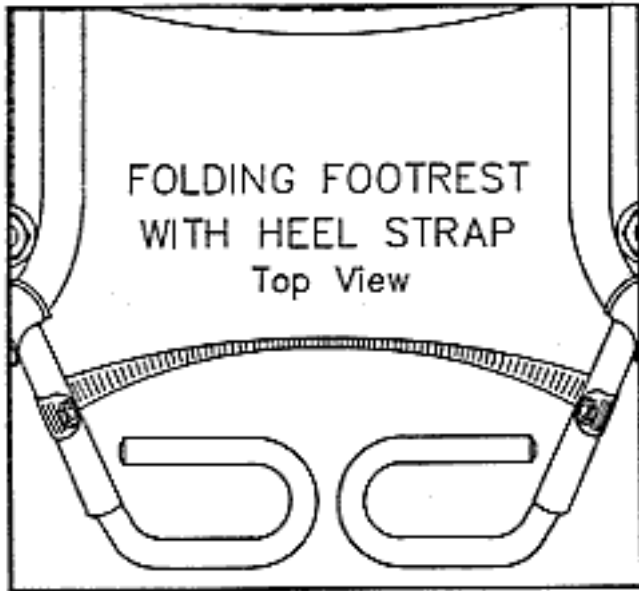

5) Connect a heel strap between the two upper footrest tubes. Punch or melt a hole in one end of the strap. If the holes fray, sew leather over the end of the strap. Using the footrest adjusting bolt, fasten the strap to the front side of the upper footrest tube.

Wrap the strap toward the outside of the chair and around the back of both footrests. Wrapping the footstrap in this manner will prevent it from becoming too tight when one footrest is folded. Punch or melt several holes in the other end of the belt to make it adjustable.

6) Some people prefer a removable footrest strap. To make the footrest strap removable, weld a 2-1/2" (6.4 cm) length of 1/4" (6 mm) diameter solid steel rod to the upper footrest tube as shown. Hook one end of the footrest strap over this rod.

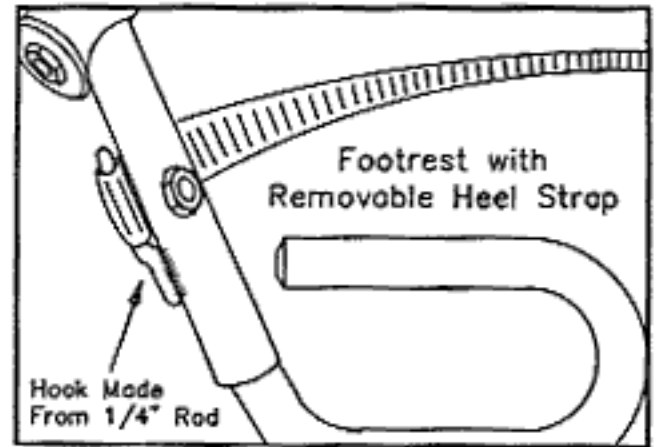

7) Slide the upper footrest tubes as far back on the sideframe as it will go. It is very important that the footrest pivot tube is touching the caster barrel. Some bronze may have to be filed off to do this.

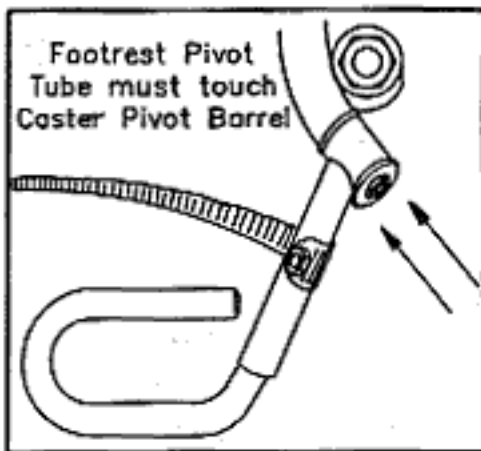

8) Cut the extra sideframe tubing off even with the ends of the footrest pivot tubes.

9) Connect each footrest securely to the chair using stoppers. To make the stoppers, weld a 1" O.D. (2.5 cm) rounded washer to the head of a 5/16" x 1-1/4" (8 mm x 3.2 cm) fine thread slotted head bolt. Make rounded washers using the same procedure described earlier in this chapter. If slotted bolts aren't available with fine threads, use a hacksaw to cut slots in the heads of two fine thread bolts.

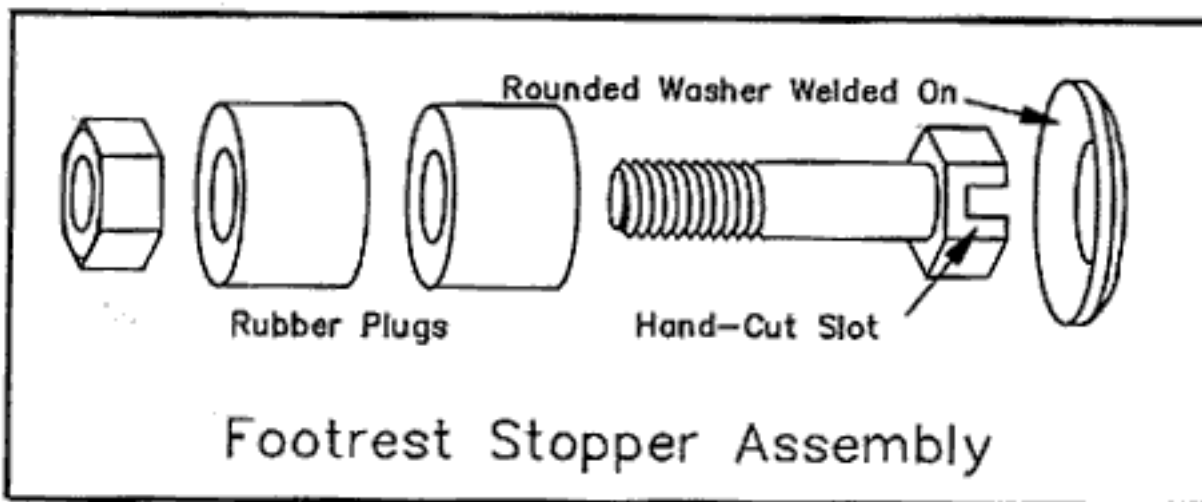

Thread a 3/4" O.D. x 1" long rubber plug over the bolt and tighten the nut loosely. Tap the stopper into the end of the sideframe tube and tighten the bolt with a screwdriver. The nut should squeeze the rubber plug enough to hold the footrest securely on the chair. Indenting the sideframe tube will help retain the footrest plug.

## THE SINGLE REMOVABLE FOOTREST

While the folding tubular footrest is our favorite, we have also included directions for another simple footrest. One of the simplest types of removable footrests is made out of two bent tubes spanning the front of the wheelchair. The footrest can be lifted and removed completely when the rider wishes to fold the chair or pull it close to the furniture.

## MATERIALS

ITEM	LENGTH	QUANTITY
1" O.D. tubing	1-1/2" (3.8 cm) long	1 piece
3/4" O.D. tubing	16" - 22" (40.6 - 55.9 cm) long	2 pieces
5/16" (8 mm) rod	8" (20.3 cm)	1 piece
3/8" (10 mm) rod	3" (7.6 cm)	1 piece

## DIRECTIONS

- 1) Cut one 1-1/2" piece of 1" O.D. tubing (or other tubing that will fit over the front of the main sideframe tubes).
- 2) Using the Hossfeld type bender with the die set for 3/4" O.D. tubing and a 1-7/8" bending radius, bend the 3/4" O.D. footrest tubes as in the drawing.
- 3) Weld one end of the footrest tubes to the 1" O.D. pivot tube. Weld the other ends to a hook bent out of 5/16" (8 mm) rod.
- 4) To prevent the footrest from falling off, make a catch out of 3/8" (10 mm) rod and weld it to the chair as shown. Add a heel strap if needed.

# Center for International Rehabilitation

## Chapter 14 Adding the Brakes

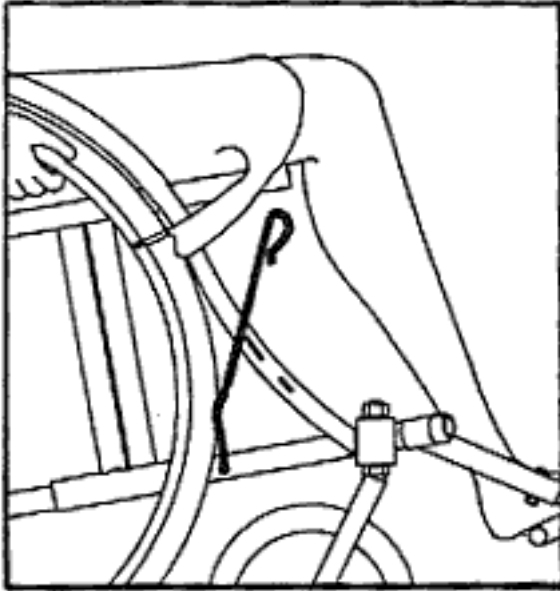

Most riders have no difficulty stopping their chair by gripping the handrims; consequently, a brake that will stop a moving wheelchair is not usually necessary. It is important, however, for the wheelchair to have a parking brake. Without a parking brake that will hold the chair securely in place, it is difficult for the rider to get in and out of the chair. The parking brakes should be easy to apply. When engaged, they should hold the wheels very tightly. Brakes that hold the wheel by pushing against the tires should be designed to hold the tire securely even when the tire is somewhat low on air.

Our favorite brake is made from a bent steel rod that can be wedged against the tire. It is simple to make and the materials are inexpensive. The brake is bent out of steel rod about 5/16" diameter (8 mm), and it pivots in a hole through the frame.

The brake is engaged by pulling it back, pressing it against the tire, and slipping it over a metal catch mounted on the sideframe. The brake will remain engaged until it is pulled out from the catch.

Even paints that adhere well to the metal are easily scratched off on the brake; consequently, the brake is another one of the parts of the chair that is best protected from rust by having it plated.

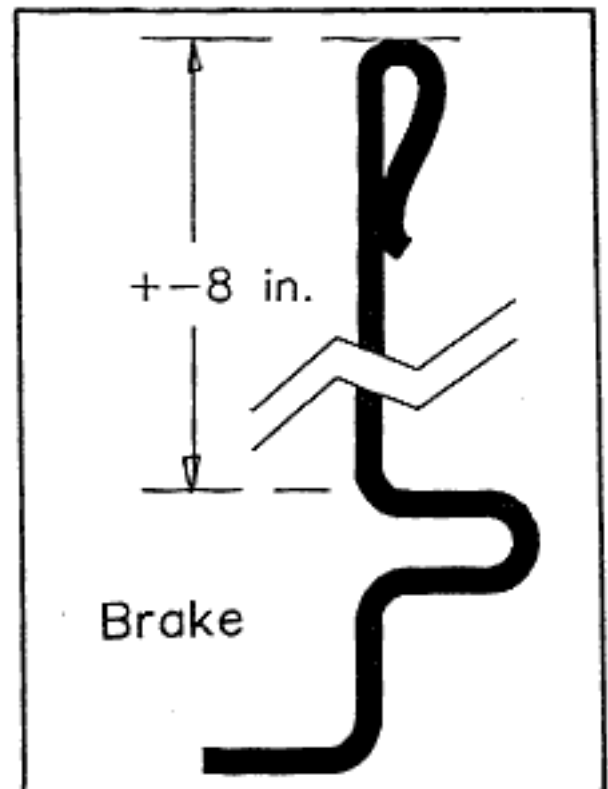

# MATERIALS

ITEM	QUANTITY
5/16" (8 mm) plated steel rod	2 pieces, 18" (45.7 cm) long
1/8" (3 mm) diameter cotter pins	2

## JIGS OR BENDERS

- Hossfeld Type Bender with rod bending parts
- Cotter Pin Hole Drilling Jig

Directions for making the jig can be found in Appendix B. Both the jig and bender can be purchased as part of the Basic Tool Kit.

## DIRECTIONS

- 1) Measure and mark the rod to indicate the bends.
- 2) Set up the bender to bend rod. The center pin should be mounted so that the end with the smallest diameter is on top. Detailed directions for setting up the bender to bend rod can be found in Chapter 6.
- 3) Line up mark #1 about 1/8" back from the point of the bending dog. (The rod will be drawn slightly into the bender as it is bent.) Tighten the bending dog until it holds the rod tightly.

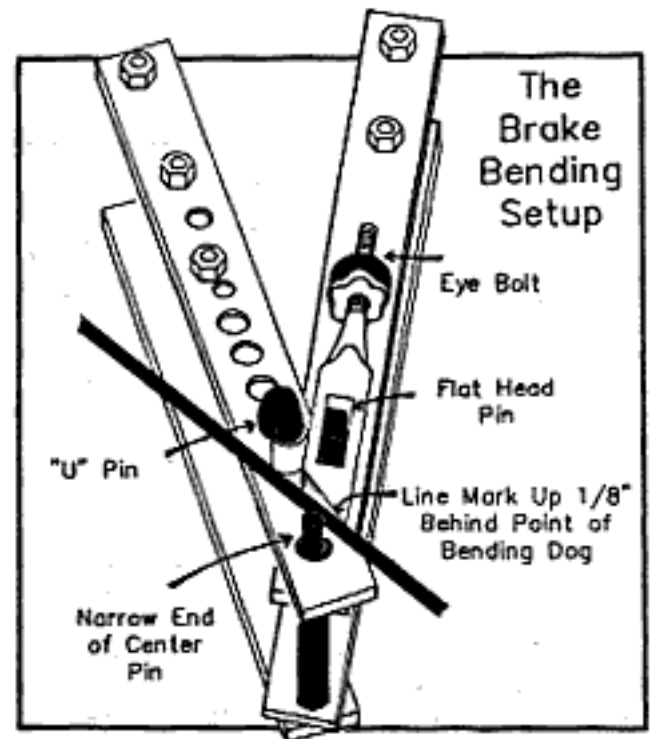
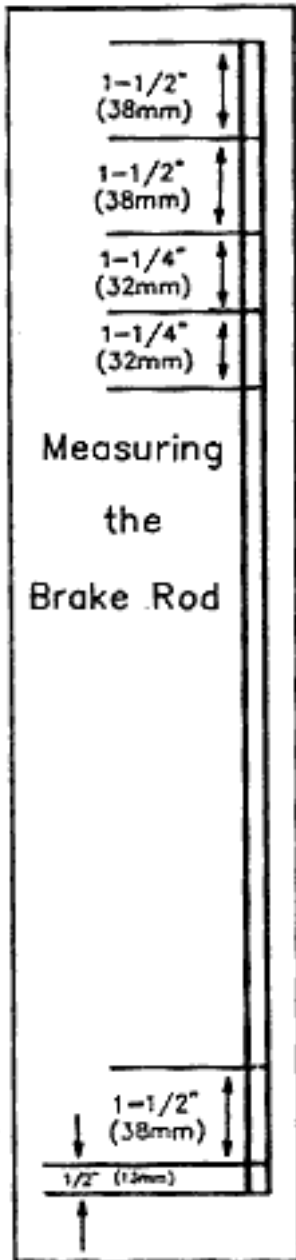

4) Bend the rod 90°. Check the bend with the angle-measuring tool and compare it to the sample brake in The Basic Tool Kit and/or to the full scale diagram at the end of this chapter.

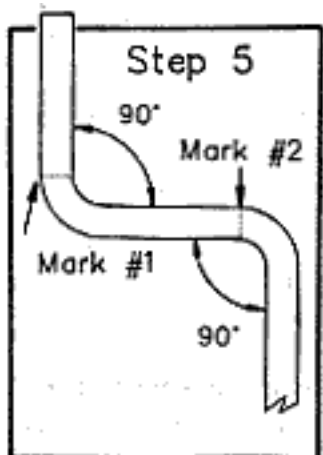

5) At mark #2, bend the rod 90° in the opposite direction. (Remember to be sure that the last bend is level in the bender, and that mark #2 is 1/8" (3 mm) behind the point of the bending dog before beginning the bend.



Orestes Quispe of Arequipa Bends to Match a Sample

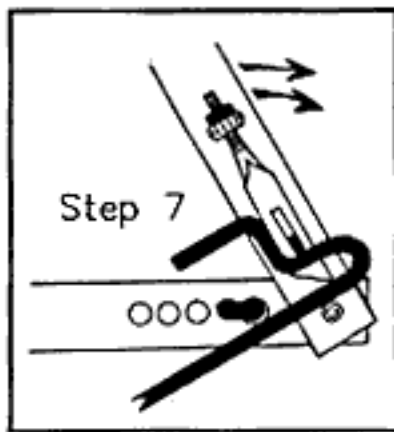
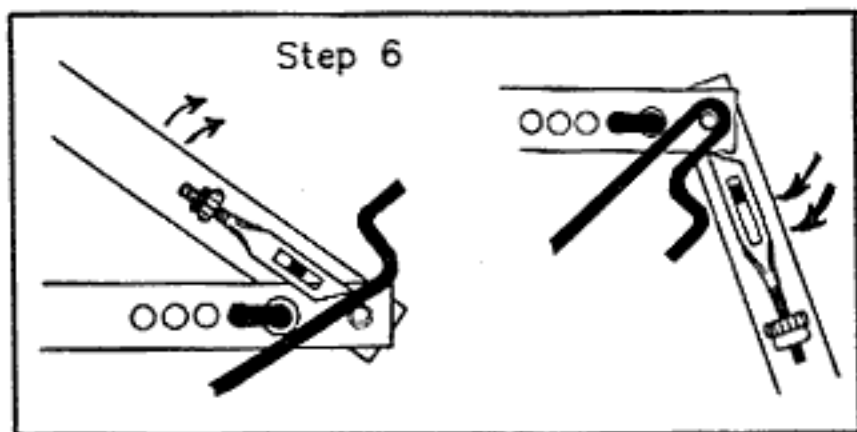

6) At mark #3, bend the rod back on itself forming a 180° angle.

7) At mark #4, bend the rod 90° in the opposite direction. The bent rod must lie on top of the eyebolt bending dog for the bend to be in the right place. As you may have guessed, this will give you a crooked brake. Cutting off the part of the flat-head pin that sticks above the eyebolt bending dog may help a bit. Don't worry that this bend will result in a curved brake. After the brake has been made, the left brake can be fixed easily and the right brake will work as is.

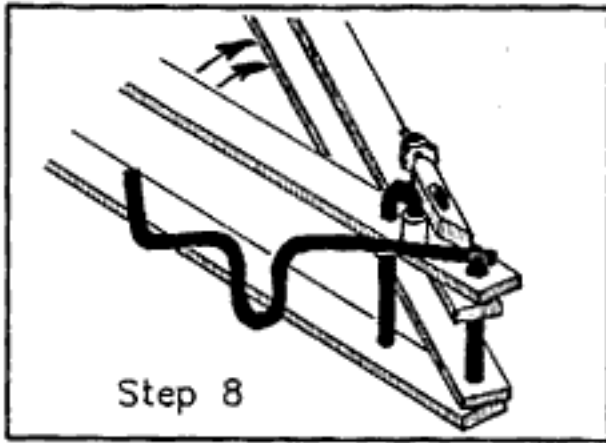

Step 8

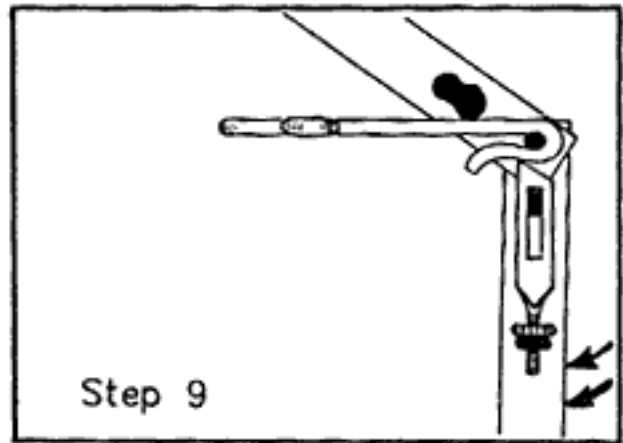

Step 9

8) Place the bar in the bender as shown, and bend the end of the handle 20~.

9) Turn the rod over (180~) and position it in the bender as shown. At mark #5, form the brake handle by bending the rod more than 180~ until it touches itself.

10) Both brakes will end up curved. The right brake can be left as is. The left brake must be straightened out and bent in the opposite direction to look like the brake in the diagram.

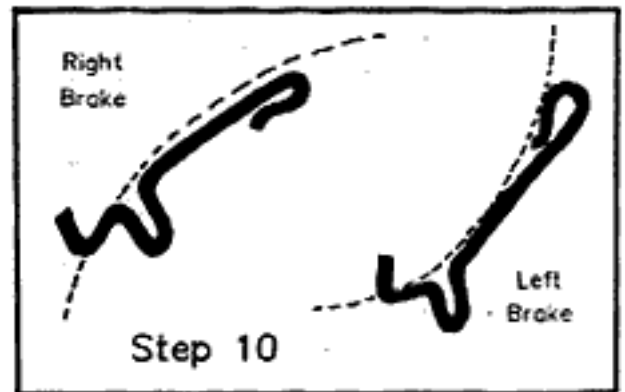

Step 10

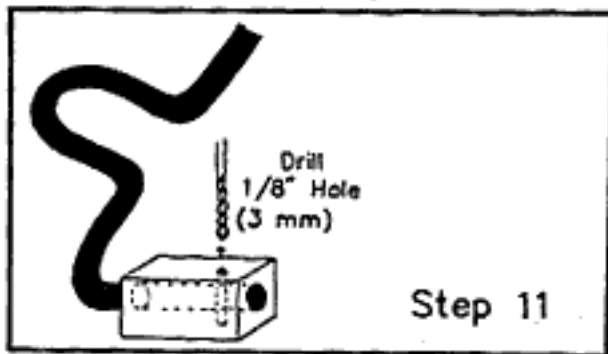

Step 11

11) Slip the cotter pin hole drilling jig over the end of the brake as shown. Clamp it in place in the drill press vise, and drill a 1/8" (3 mm) hole.

12) Weld two reinforcing washers with an inside diameter of 5/16" (8mm) over the brake mounting holes that were drilled in the sideframes ahead of the X-braces. If washers with these exact hole sizes are not available, buy smaller washers and ream them out to the right size.

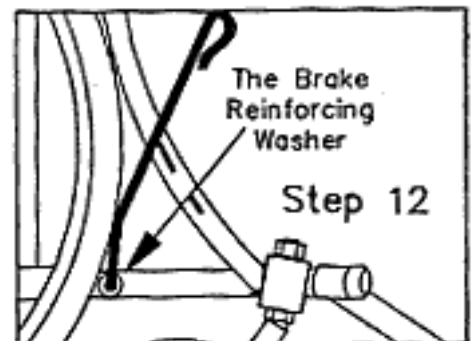

Step 12

13) Mount the brakes through the brake mounting holes. Once you are sure that the rear tires are properly inflated, check the adjustment of the brakes. The brakes should dig into the tire about 1/4" (6 mm) when they are locked, but locking the brakes should not be difficult. Remove the brakes and bend them in a vise until they are well adjusted. When completed insert the cotter pins to hold the brakes in place.

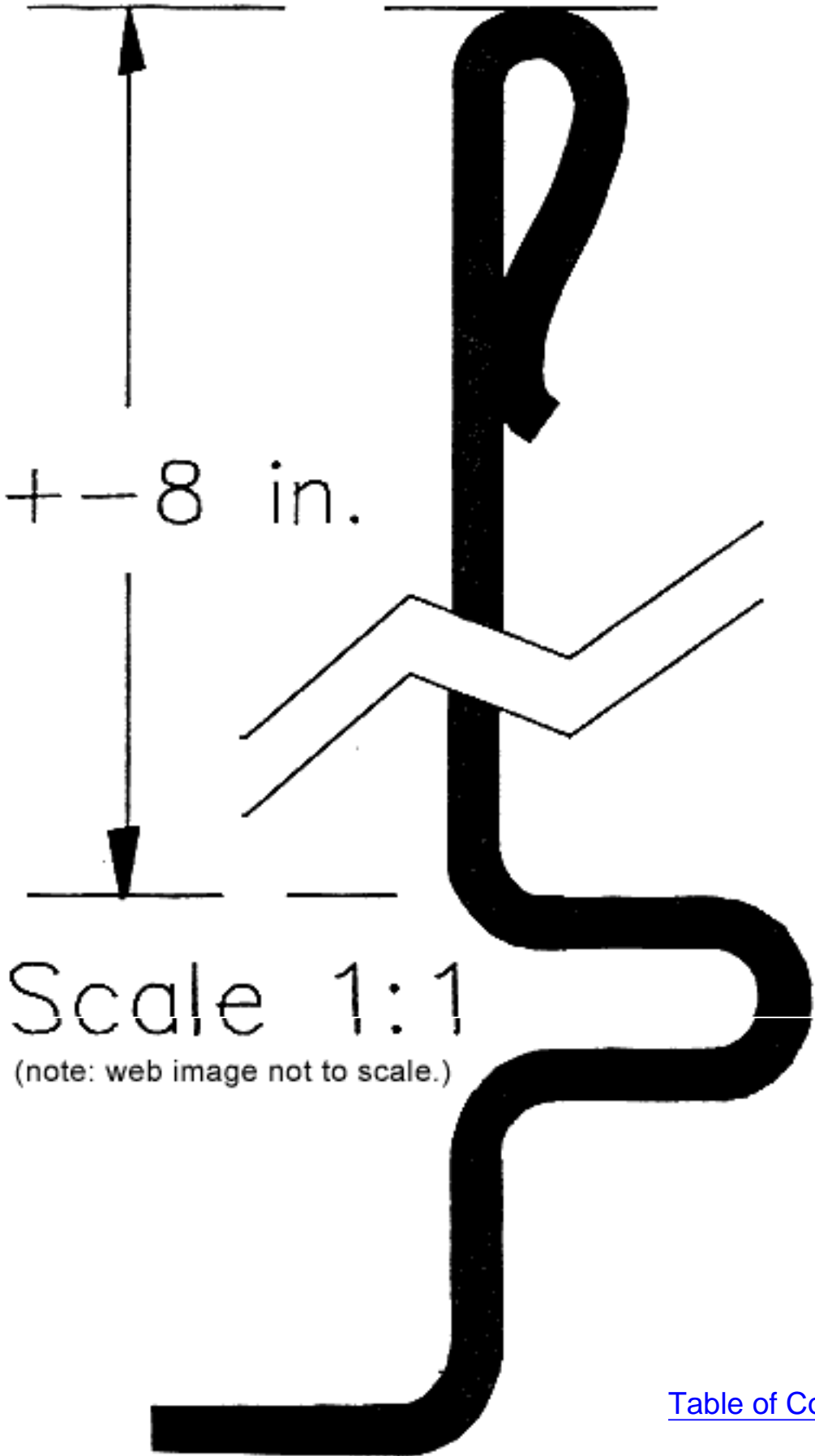



# Center for International Rehabilitation

## Chapter 15 Sewing the Seat and Back



Juan Becera of Peru

Fitting the seat and back upholstery for a wheelchair rider is the final step in making a customized wheelchair. You can reduce the outside width of the chair, and the rider will travel much more freely if the upholstery is no wider than necessary. This chapter describes how to make long lasting upholstery at a minimum of cost.

Although many different materials have been used for wheelchair seats, including cane, wood, and metal, we have chosen a sling seat made of heavy canvas. All seats can cause pressure sores unless they are used with an adequate (usually thick) cushion. We prefer sling seats because they conform somewhat to the shape of the wheelchair rider's bottom. With a sling seat, many people can use a thinner or softer cushion without becoming uncomfortable or getting sores. Once a pressure sore develops, the wheelchair rider must remove the pressure immediately to avoid a serious medical problem. Wheelchair riders who have a spinal cord injury or other disability that limits sensation must take special care. Healing can be slow, and a tiny irritation can quickly become a deadly infection. Pressure sores have killed many disabled people, including one of our fellow wheelchair builders, because the prevention and treatment of the sores were not taken seriously.

Flexible seat materials stretch with time and use. As the fabric sags, the design of many wheelchairs forces the rider's weight to press on the metal seat support tubes. Even with a cushion, discomfort or sores usually result. The ATI-Hotchkiss chair unfolds, widening further and further to take up the slack as the canvas stretches, until the seat guide hooks hit the axle sockets. Do not make the canvas seat so wide (and the seat tubes so low) that the seat hooks can not move down any further. See the chart in Chapter 4 for maximum seat widths.

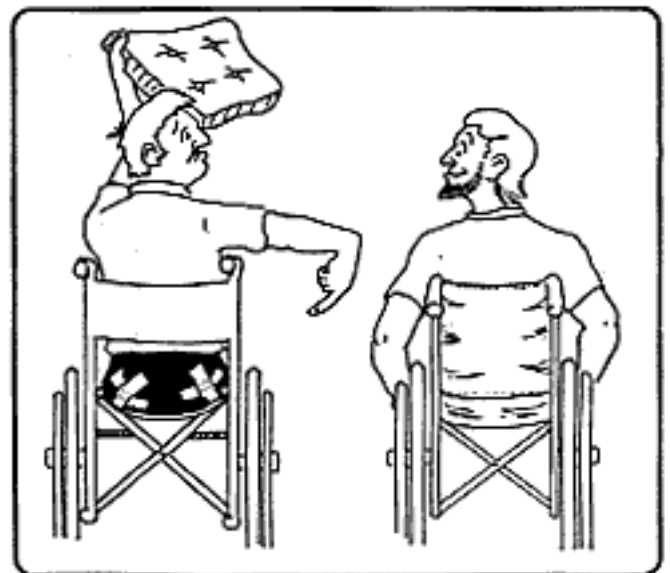

## MATERIALS

ITEM	QUANTITY	PART OF CHAIR
Heavy canvas, cotton or synthetic	6' x 3-1/2' (183 cm x 107 cm)	Seat and Back
1/16" x 1/2" steel bar (2 mm x 12 mm)	4 pieces, 16" (40.6 cm) long	Edge Bars
#12 sheet metal screws	8 screws, 3/4" (19 mm) long	Seat Back Screws
3/16" (5 mm) fine thread bolts and locknuts	8 bolts, 1-1/4" (3.2 cm) long	Seat Bolts
Thread or cord*	24 yards or meters	---
Leather or waterproof imitation leather**	3' x 20+" (91 cm x 51+ cm)	Protective Covering

\* Neither machine nor hand stitching will hold up if the thread is not strong enough. Finding good quality thread has been very difficult in some countries, especially if the thread must be used in a sewing machine. The thread must be very tightly wound and must be strong enough that it is difficult to break by hand. If the best machine thread available is still too weak, a heavier hand stitching cord may be the only alternative.

\*\* A single layer of waterproof imitation leather or genuine leather can help prevent the canvas from wearing out. In most countries imitation leather is cheaper than genuine leather; however, it can be hot and sticky and increase the chances of some people getting pressure sores. In any climate, genuine leather or plain cotton canvas is the best choice.

## TOOLS

We have used three types of sewing tools successfully: an awl with a needle and thread, a stitching awl, and a heavy duty sewing machine. We have designed the upholstery so that it can be made with a minimum amount of stitching; it should take no more than an hour to stitch a set of upholstery, even if you are using a hand stitching awl.



Ralf Hotchkiss and Juan Becerra  
Sewing the Canvas

## DIRECTIONS

The seat back upholstery and the seat upholstery are made in the same way. The following directions describe how to make the seat and seat back upholstery when the length of the seat is the same as the height of the back. If the seat back is longer or shorter, adjust your measurements accordingly. When installing the seat back, set it very high on the chair frame tubes. The top of the seat back should always come very close to the push handles.

### 1) Measure and cut the canvas.

The canvas should be twice as wide as the seat will be plus 1-1/2" (38 mm) for the seam. For an extra strong seat, the canvas should be twice as long as the length of the seat (or height of the back).

If you do not make the canvas twice as long as the seat (or height of the back), be sure to cut the fabric at least 8" (20 cm) longer than the length of the seat in order to add reinforcement to areas that usually wear out first (the front of the seat and the top of the seat back).

### 2) Sew each piece of canvas into a tube by folding the fabric in half and sewing a 3/4" (19 mm) seam along the open edge. Iron or fold the seam so that all the seam material lies to one side.

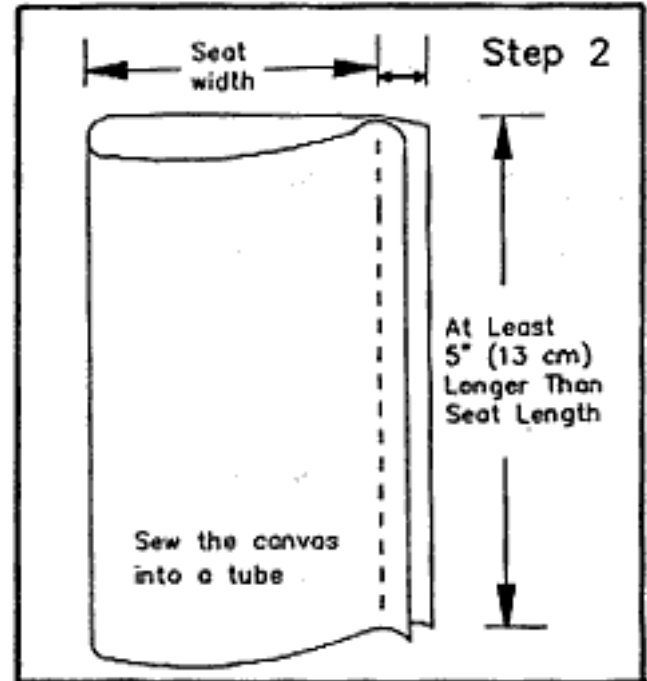

### 3) Turn each tube inside out. Tuck the excess length into the ends of the tube.

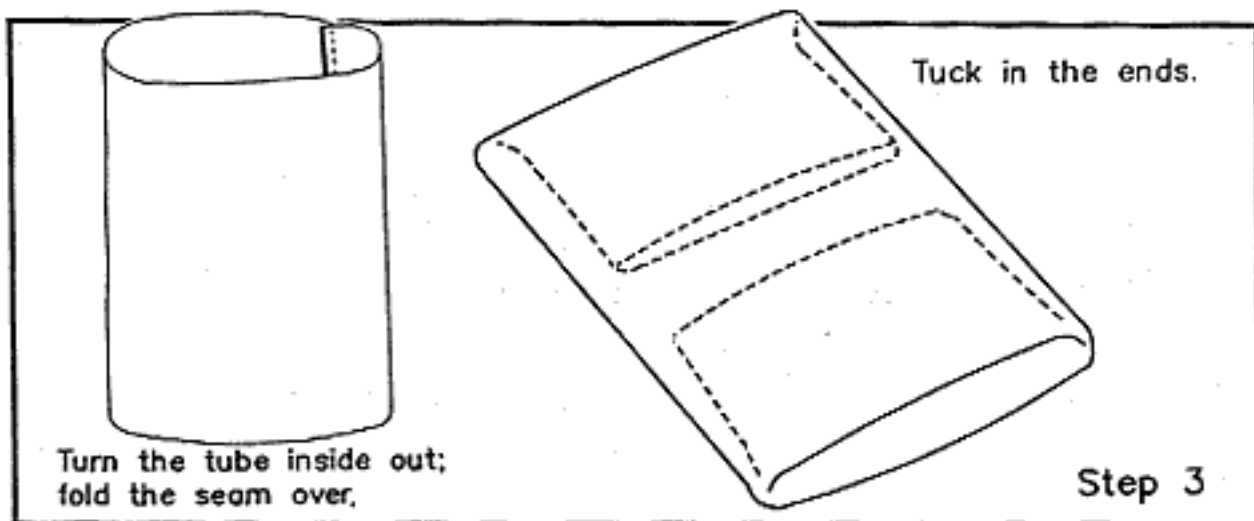

4) Arrange the material so that the seam is an inch or two (3 - 5 cm) from one edge. The extra hem material should point away from the edge. Don't put the seam in the middle where it could press against the spine or tailbone, causing pressure sores.

5) Sew a 1/4" (6 mm) seam along the front edge of the seat canvas and along the bottom edge of the seat back canvas. The seam will keep the canvas from shifting. Leave the other end open to make it easy to insert the edge bars.

### MAKING THE EDGE BARS

1) Cut the two seat edge bars and the two seat back edge bars. The edge bars are made from 1/16" x 1/2" (2 mm x 12 mm) steel bar. A standard chair uses four 16" (40.6 cm) edge bars. If the chair you are making has a shorter or longer seat back height, you will need to adjust the measurements accordingly.

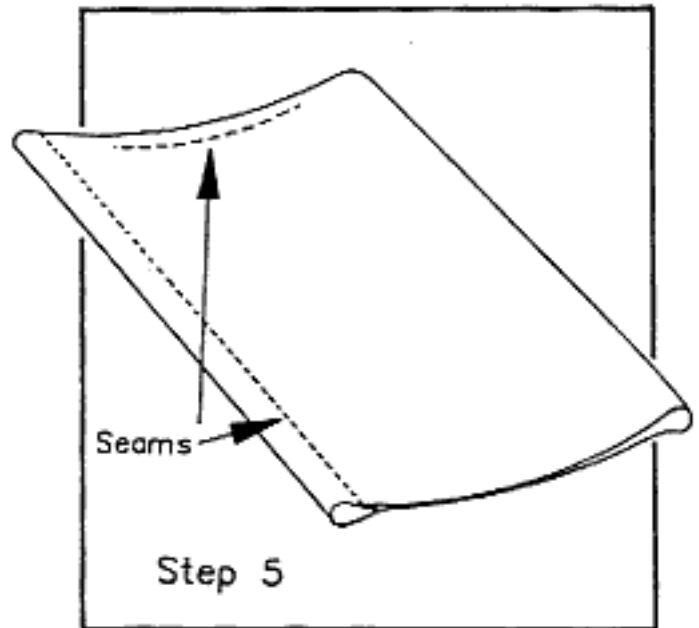

2) Using the seat support tube drilling jig with the edge bar insert, drill five 3/16" or 7/32" (5 or 6 mm; the larger size for easier assembly) holes in the seat edge bars and seat back bars.

Place a seat edge bar in the channel of the wooden edge bar drilling insert, and slide them into the drilling jig until they hit the stop bar. Both the edge bar and wooden insert will stick out from the drilling jig on one end. Clamp the insert securely to the jig using two C-clamps as shown. Place it on the drill press table and drill all five holes. Repeat the same procedure with the other seat edge bar.

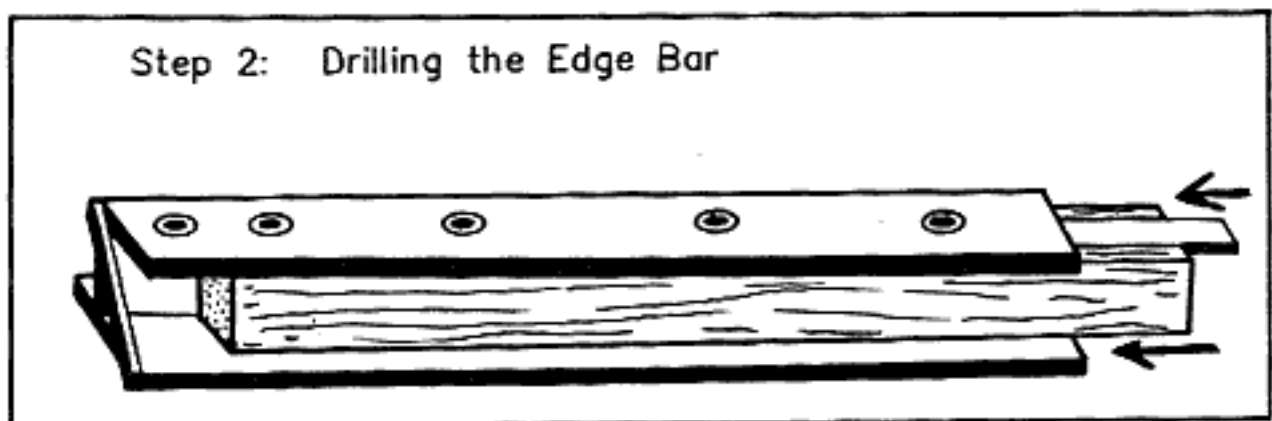

The jig will space the holes as shown in the diagram. A #12 sheet metal screw should slide freely through the holes in the seat back bar.

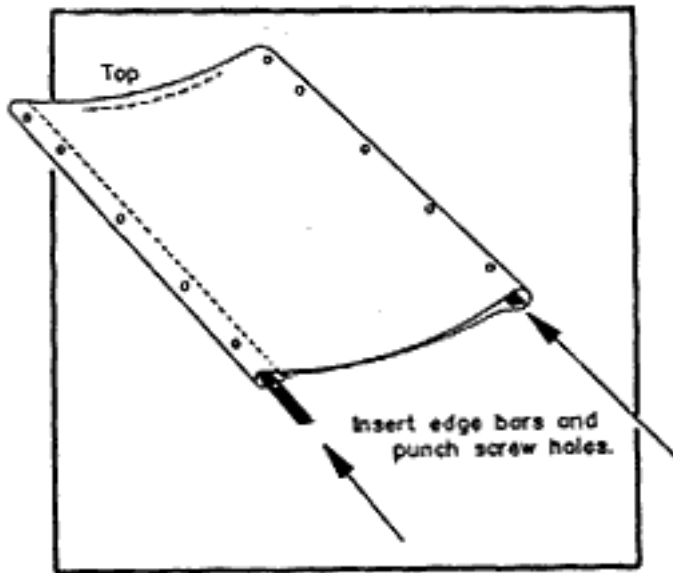

## ASSEMBLING THE SEAT AND SEAT BACK

1) Insert the edge bars into the upholstery so that the holes closest to the ends of the edge bars are positioned on the top of the seat back or toward the front of the seat.

Be sure the bars don't catch on some of the inner layers of canvas. Once they are properly positioned, poke holes in the fabric by pushing a scribe through the fabric and into the holes in the edge bars. The basic seat or seat back is now finished.

2) If you wish to add some decorative or protective covering to the upholstery, cut a piece that is big enough to wrap around all four edges of the canvas. Sew, rivet, or glue it in place. Some wheelchair makers have used contact cement to hold leather in place while sewing. This works, but the glue is dangerous to breathe or touch over a long period of time.

When using contact cement, have plenty of fresh air. Do not apply the glue with your bare hands!

3) Attach the seat to the seat support tubes with 3/16" (5 mm) bolts and nuts.

4) Attach the seat back to the back frame with #12 sheet metal screws.



# Center for International Rehabilitation

## Chapter 16 Final Testing



Before selling the completed wheelchair, take it out for a test run. While the chair may not withstand every type of abuse -- being tossed off the roof of a bus or dragged through a dense forest by a reluctant burro -- it should be sturdy enough to withstand heavy use, it should be well aligned, and it should fold easily. The following five tests are designed to determine if the chair is ready to be sold to a customer.

### TEST #1

Inspect the chair very carefully for sharp edges. All square corners must be rounded with a file, and exposed tube ends must be covered with an ovalized washer.

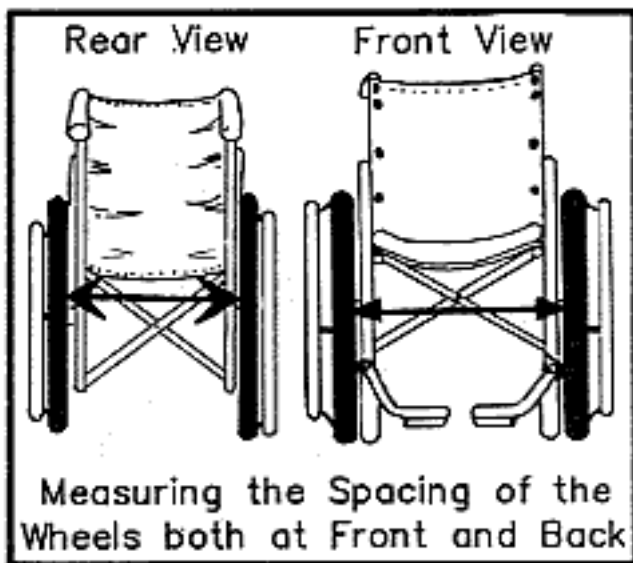

### TEST #2

Make sure that both rear wheels are aimed in the same direction. Use a tape measure to measure the distance between the rear wheels in both the back and front of the chair. If there is more than 1/4" (6 mm) difference between these two measurements, take off the wheels, use a piece of solid rod for leverage and bend the axle sockets into alignment. The rear wheels on racing chairs or chairs for people who will be doing a lot of high speed travel should be even more exactly aligned. If the two measurements differ by more than 1/8" (3 mm), the axle sockets should be realigned.



## TEST #3

Check to see that both rear tires are equally inflated. If one tire is low, it will cause the chair to turn toward that side.

## TEST #4

Ride the chair over a level area. See if the chair pulls to the left or right. If it pulls to one side, remove the front wheels and check to be sure that caster fork arms are lined up with their pivot bolts. If one or both caster forks have been welded to their pivot bolts incorrectly, this will cause the chair to pull to one side.

If the angle is slightly off, try bending the arms of the caster fork until they are aligned correctly. Put one arm of the fork into the vise, slip a piece of pipe over the bolt to use as a lever, and bend it until the fork is properly aligned. Repeat the same procedure on the other arm of the caster fork.

If the pivot bolt is seriously out of alignment with the caster fork, heat the weld with a torch and realign it.

If the caster fork arms and pivot bolts appear to be well aligned, but the chair still pulls to one side, check to be sure that the caster barrels have been welded on correctly. If a caster barrel tilts to one side, it can turn the chair sharply in that direction. To bend it back into alignment, fit a long rod or pipe tightly into the caster barrel and bend the barrel until it points straight up and down.

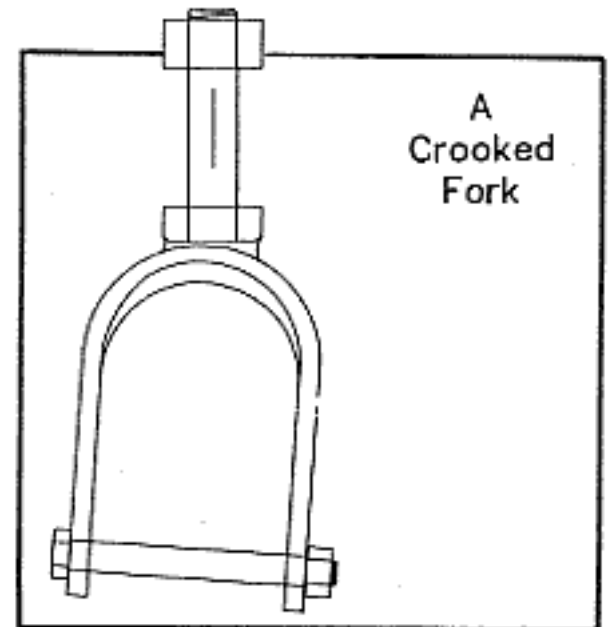

## TEST #5

The chair is folded completely when the rear axle bolts touch each other. Check to be sure that the chair folds smoothly and completely. If it doesn't fold easily, see if the seat hooks are binding on the seat back tubes. If they are, twist them up or down until they slide easily.

## TEST #6

Check the brake adjustment. The brakes should be easy to operate, and should dig into the tire about 1/4 inch (6 mm). If the brakes press against the tire too much or too little, remove the brakes from the frame and bend them accordingly.

# Center for International Rehabilitation

## Chapter 17 Taking Care of the Chair



The wheelchair you have just built will last longer, ride more smoothly, and fold more easily if it is maintained periodically. After one month of use every chair will need to have its bolts and spokes tightened. From then on the wheelchair will need to be serviced every four to six months.

It is not difficult to service the chair, and we recommend that your shop encourage the new wheelchair owner to service the chair him or herself. The new owner will need access to a few simple tools and supplies: a spoke wrench, an adjustable wrench, a bicycle pump, a tire gauge, a screwdriver, some medium weight machine oil, and some wax. Your shop may wish to stock these tools and supplies to sell to the customers who buy your chairs.

Go over the directions on the following page with your customers to be sure that they understand how to take care of their chairs. You may also wish to duplicate the directions and give each customer a copy.



# **TAKING CARE OF YOUR NEW WHEELCHAIR**

## **AFTER ONE MONTH**

1. Check the spokes in the back wheel. Use the spoke wrench to tighten any that are loose.
2. Inflate rear tires to rated pressure.
3. Tighten the following screws and bolts: seat back screws, seat bolts, handrim bolts, x-brace bolt, footrest bolts, front axle bolts, rear axle bolts, front caster pivot bolts.

The front caster pivot bolt should be just tight enough to cause a little resistance. This will keep the front wheels from vibrating wildly when the chair is rolling quickly. Don't tighten it too much, or the chair will be difficult to steer.

4. Use medium weight machine oil to oil the center and bottom of the x-brace.
5. Wax the back frame where the guide hooks slide up and down. This will help the chair to open and close more easily.

## **EVERY 4 - 6 MONTHS**

1. Repeat all the steps listed above.
2. Check the seat fabric, and replace it if it is torn or if it sags too far. This is very important; sagging or torn upholstery can lead to pressure sores.
3. If you are using a foam cushion, check to be sure that it is still springy. A foam cushion that has lost all its bounce can also lead to pressure sores.

## **FLAT OR WORN-OUT TIRES**

The back tires can be fixed or replaced by a bicycle repair person. Be sure to replace your tire with one that is exactly the same size.

The front tires, whether they are pneumatic (filled with air) or solid rubber, will need to be replaced by a wheelchair shop.

# Center for International Rehabilitation

## Whirlwind Africa 1

### Finding Seat Heights and Seat Widths - Standard Sizes

To figure out the size wheelchair to build for your customer you will need to measure your customer to find the **seat width**.

#### Finding the Seat Width

Have your customer sit in a wheelchair, or a table, that is larger than she is. Slide books in on either side of her until the books just touch but are not squeezing her hips. A seat this wide will give most riders enough room to move while still keeping the chair reasonable narrow. Measure the distance between the two books and use this measurement for the width of the seat.



#### Standard Seat Heights for 24" and 26" rear wheels

We have set some standard seat heights for common wheel sizes. See Page ? if you want to make special seat heights.

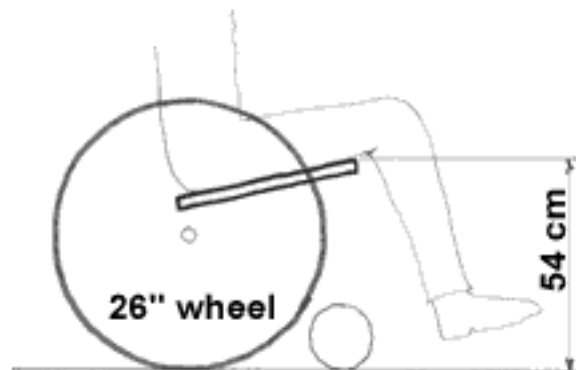
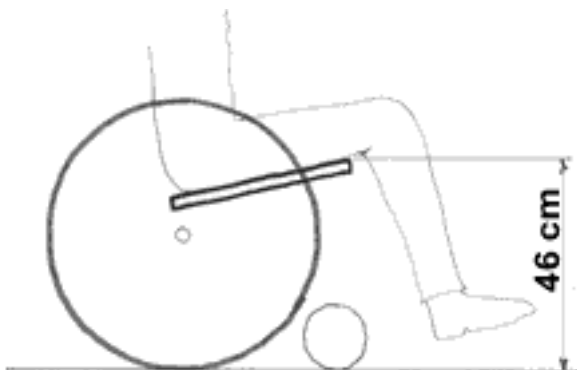

See Jigs and Fixtures Drawings for full scale

## Making Cross Tubes for Standard Sizes

1. Find the seat width that fits your client.
2. Find the size to cut your cross tube for the wheel size you are using
3. Drill holes centered in the square tube.

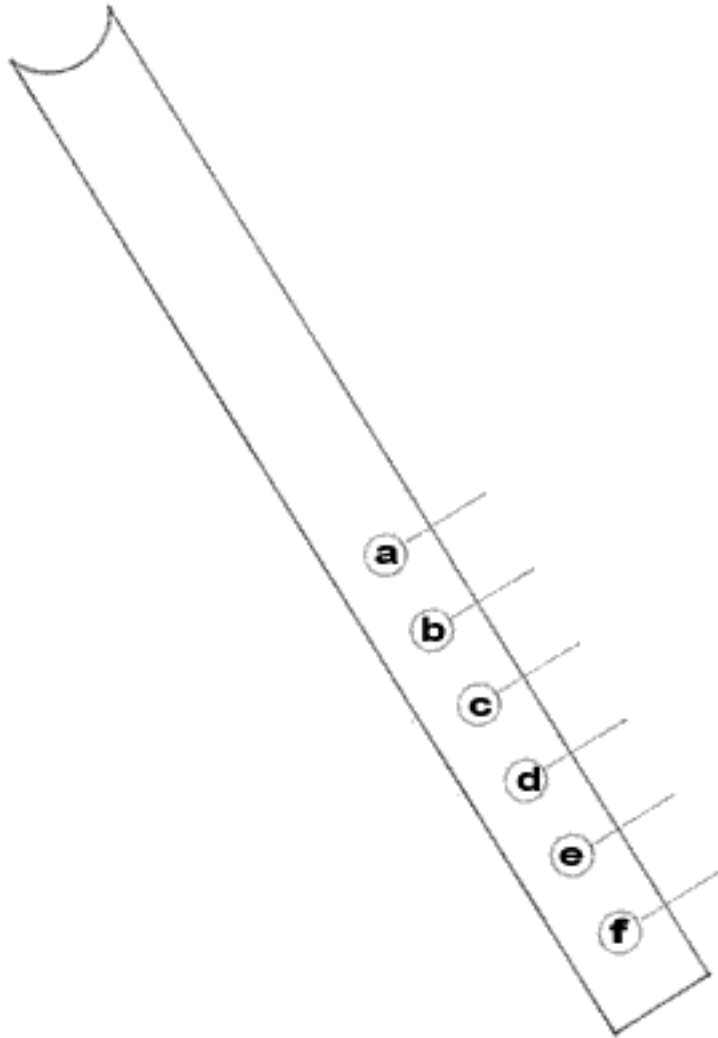

	Cut length	24" wheel	26" wheel
a	28cm	24cm	20cm
b	32cm	29cm	26cm
c	36cm	34cm	31cm
d	40cm	39cm	36cm
e	44cm	42cm	41cm
f	48cm	47cm	46cm

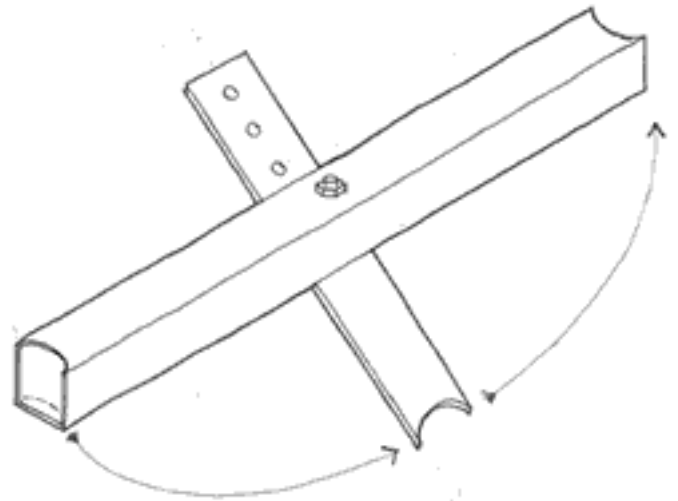

## Metal Working Techniques

To round the ends of your round tubing, you can use Tube Ending Tools. See Drawings Jigs and Fixtures.

[Table of Contents](#)

# Center for International Rehabilitation

## Whirlwind Junior

### Children's, Small, and custom sizes

#### Changing the Wheelchair for Children and Shorter People:

- Use 20" wheels if possible
- cross tubes for 20" wheels
- Fender and seat tubes for 20": wheels
- Short footrest
- Fork for 20" wheels
- Handrims for 20" wheels
- Long Brakes
- Small Upholstery

#### Using 20" Wheels

For small people, 20" rear wheels works the best. If you use large 24" or 26" wheels, the children are either too high in the seat and tip over easily or cannot reach the floor, or the seat is too low and they have a difficult time reaching the handrims.

#### Measuring Seat Width

Add 3 cm to the seat width for growing children.

#### Standard Seat Height for 20" Wheels:

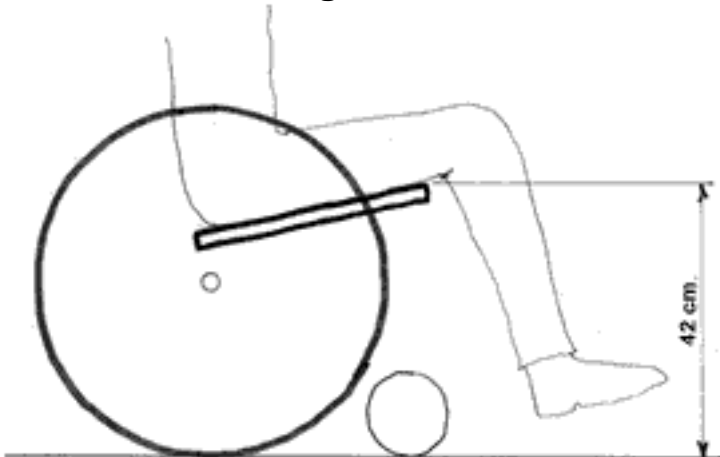

## Cross Tubes Table for 20" Wheel

Cut	20" wheel
28cm	47cm
32cm	42cm
36cm	38cm
40cm	33cm
44cm	28cm
48cm	25cm

### Fender For 20" Wheels:

Follow the blueprint drawings for the bend. Mount the fender UNDER the pins on the side of the frame.

### Seat Tube for Small Wheelchairs

Cut the seat tubes 375mm.

### Footrest for Short Legs

If your customer's legs are 27cm or shorter, you will need to make a single footrest.

The footrest also deeper for growing children's feet.

Footrest Size	Seat Width
Very small	26 —31cm (10.5"-12")
Small	32-36cm (12.5"-14")

Some people use the second seat as a footrest. But it is only good for feet of one length.

### **Fork for 20" Wheels**

If you use 20" rear wheels, the front fork will also have to be shorter.

### **Handrim for 20" Wheels**

Make a new handrim bender:

### **Brakes for People with Shorter Arm Reach**

Make the brake handle a little longer so that people with short arms can reach them easier.

### **Upholstery for Narrow People:**

Small upholstery pattern for seat 23-33cm wide

See Blueprints

## **Customizing Wheelchair Sizes**

### **Changing the Wheelchair Size**

You can customize the wheelchair size in three ways

1. Change the upholstery width
2. Change the wheel size and upholstery
3. Change the cross tube length

#### **1. Changing the Wheelchair Size by Changing the Upholstery**

If you tighten the upholstery the wheelchair will be higher and narrower. If you loosen the upholstery the wheelchair will be lower and wider. So you can make a variety of seat widths and lengths that are not shown on the table.

If you make the wheelchair seat higher, the seat width will be narrower. 1cm higher seat = 1 or 1.5 cm narrower seat

If you make the seat lower, the seat width will be wider. 1cm lower sea height = 1 or 1.5cm wider seat.

You want to make seat 50cm high, 25cm wide using 24" wheels. This is 4cm higher than the standard size. That means that your seat width will be 4-5cm narrower than what is shown in the table.

## **2. Changing the Wheelchair Size by Changing the Wheels**

Smaller wheels = lower and wider seat

Bigger wheels = higher and wider seat

This means that children can use the same wheelchair frame and change the size (both the height and the width) as they grow by using larger wheels.

## **3. Changing the Wheelchair Size by Customizing Seat Height**

There are 3 factors that you must think about to set the seat height.

- a. For short people: how easily the person can reach and push the handrims
- b. For tall people: make the seat is high enough so that their feet do not hit the floor
- c. For using the wheelchair daily: keep the wheelchair low enough so that your customer can fit under some tables and the wheelchair does not tip over too easily.

### **a) Finding the Seat Height for Stability and Reach:**

The lower the seat height the easier it will be for your customer to get under tables, sweep floors and pick things up off the floor. A lower seat height will also make the wheelchair more stable when going over uneven ground. The higher the seat, the easier your customer will tip over!

### **b) Finding the Seat Height for Tall People:**

One of the most important measurements for tall people is their calf or lower leg measurement. Your customer's seat has to be high enough so that his feet will not hit the ground. We add another 5cm (2") so that on uneven ground he will not hit his feet either.

So for tall people you will need to make the seat height 5cm (2") longer than his lower leg.

If your customer's feet end up lower than the floor, you may suggest adding some cushioning at the front edge of the seat.

### c) Finding the Best Seat Height for Short People:

The most important measurement for short people is the elbow to seat height. Most people like to have their elbow 2.5cm or 1" above the handrim. At that height they can push the handrims with the most force.

*Option: See the end of this section for people with upper body disabilities.*

1. **Sitting:** Have your customer sit in a wheelchair or on a table. If they will be using a cushion, have them sit on the same cushion or a very similar cushion when you are measuring them. They should also be using their normal footwear.
2. **Elbow Height:** Have your customer sit upright with their shoulders as they normally sit. Measure their elbow height (distance from the bottom of their elbow to the table or wheelchair seat height).
3. **Handrim Height -** Now you need to find what seat height to make the wheelchair to put your customer's elbow in the right height. First find what wheel and handrim size you are using. Then you can decide what seat height to use.

However, the seat should not be higher than 54 cm (21.5") or the wheelchair will tip over the side too easily.

### **Customizing Seat Height for People with Upper Body Disabilities**

When finding out the correct Seat Height. Some people may be stronger if their elbow is higher or lower than the usual 2.5cm or 1inch above the handrim. Some people also have different length arms from right to left, or their back may be twisted making one shoulder higher than the other.

If you are working with someone with unusual arm dimensions, the best way to find out how high they should sit above the handrim is to test it. We have found that if you sit behind the customer and have her pull on your finger at different heights, you can tell at which height she can push the handrims the strongest. It is a good idea to test both arms. Sometimes it's good to pick the height for the weakest arm.

### **"Growing" the Wheelchair For Children:**

Add 3cm seat width to allow for the children to grow.      Loosen the upholstery.

Change the wheel and fork sizes.

[Table of Contents](#)



# Center for International Rehabilitation

## Appendix A Making Your Own Benders

### BENDER FRAME TO USE WITH HOSSFELD DIES

As was mentioned in Chapter 2, we recommend that you purchase the dies for bending tubing, bar and rod from Hossfeld. These dies are used in a bending frame that can be built by a skilled mechanic. If you'd rather not make your own frame, you can order a frame, with the dies, either from Appropriate Technology International or directly from Hossfeld.

The bender frame has two main parts: an outer arm that is bolted to a heavy wooden work bench and an inner arm that pivots inside the outer arm. Each arm is made up of two steel bars with a precise pattern of holes drilled in them. The pattern of holes drilled in bars forming the outer frame is different than the pattern of holes drilled in the bars forming the inner frame.

To make the bender frame, you will need a couple of tools that are not used in making the wheelchair: a 3/8" tap (for cutting threads) and 5/8" (16mm) and 3/4" (19mm) drill bits. This bender has been designed using English dimensions. Since the dimensions of the bender frame must be precise for the dies to bend tubing without wrinkling it, there is some risk in building the frame using metric measurements that are only approximately equivalent to the English. For this reason we have not given metric equivalents for most of the bender dimensions.

### MATERIALS

ITEM	SIZE	QUANTITY
1/2" x 2" (12mm x 50mm) Steel Bar	16" (40.6cm) long	4 pieces
1/2" x 2" (12mm x 50mm) Steel Bar	8" (20.3cm) long	3
	5" (12.7cm) long	3
3/4" Waterpipe or similar thickwall tube	3" (7.6cm) long	2
	4" (10.2cm) long	2

(Any thickwall tubing from 1 to 1-1/2" O.D. [25mm - 40mm] will do.)

# Bender Frame

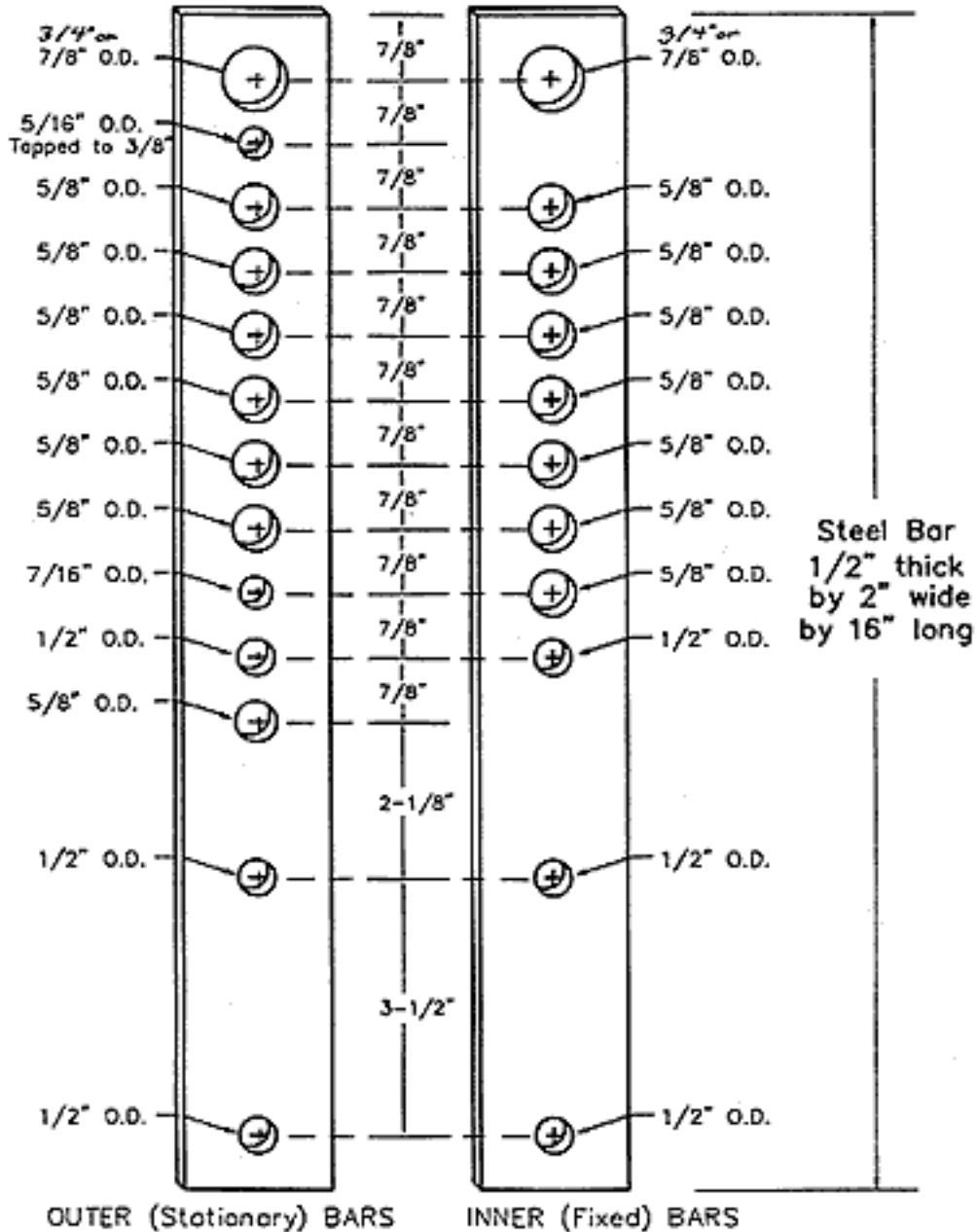

## DIRECTIONS

1) Carefully mark and center punch each hole in the locations given in the diagram. Make two identical inner bars and two identical outer bars.

**IT IS VERY IMPORTANT THAT THE HOLES ARE LOCATED ACCURATELY!** If they are off 1/16" (1.5mm), your tubing is likely to kink when you try to bend it. (See Chapter 6 for directions on how to drill holes accurately.)

2) Drill a starter hole at each mark using a center drill; finish drilling all the holes with a regular drill bit.

3) In one of the outer arm bars, thread the two 5/16" (8mm) holes with a 3/8" (10mm) tap (thread cutter).

4) Cut four spacer tubes from 3/4" waterpipe (any thickwall tubing with an outside diameter between 1" (25mm) and 1-1/2" [38mm] will do). Cut two of these spacer tubes 3" (7.6cm) long and two 4" (10.2cm) long.

## ASSEMBLING THE BENDER

1) Mark and drill three 1/2" (12mm) holes in the corner of a heavy wooden work bench. Use one of the outer frame bars to locate the holes. When the frame is mounted, most of it must stick out beyond the work bench. Consult the diagram to see about how far the bar can stick out beyond the work bench.

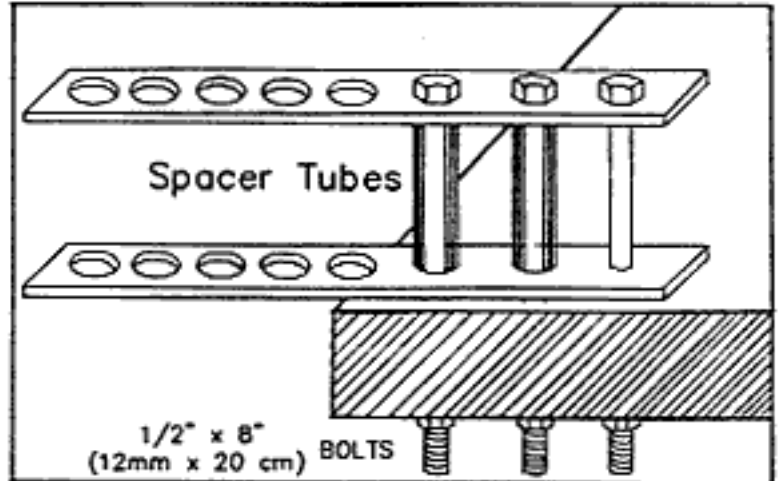

2) Begin by assembling the inner moveable arm of the frame. Bolt the two inner frame bars together using the 5" (12cm) bolts and 3" (7.6cm) spacer tubes. Note that the bolt on the end does not use a spacer tube.

3) Assemble the outer arm of the frame using the 8" (20cm) bolts and 4" (10.2cm) long spacer tubes; bolt it to the work bench as shown. The frame bar with the 3/8" (10mm) threaded holes should go on the bottom.

4) Connect the inner and outer arms of the frame to one another using the Center Pin and Center Pin Support Plate (or a standard series 1/2" [12mm] I.D. washer) as shown.

The Center Pin and Center Pin Support Plate can be purchased from Hossfeld; they are also included in the Basic Tool Kit.

Attach the Center Pin Support Plate (or washer) with a 3/8" (10mm) bolt that is 1/2" (12mm) long. Screw the bolt into the threaded hole located next to the center pin. The edge of the washer or Center Pin Support Plate will catch the Center Pin preventing it from sliding through.

5) To make the bender more easily usable by many disabled people, mount an auto jack on it as shown. The jack is the type used on most large U.S. autos; a 1/2" (12mm) diameter hole must be drilled in the end of the jack to mount it on the bender.

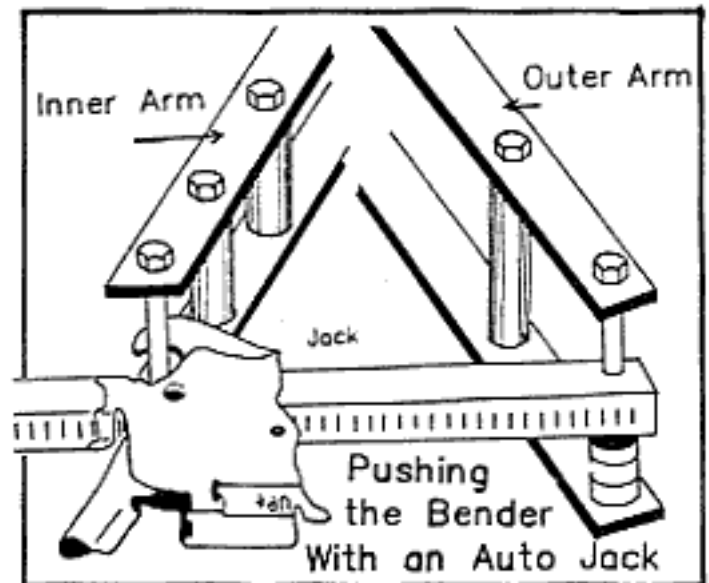

# MAKING A WOODEN BENDER AND DIES

This bender has been designed to make large radius, gentle bends for the handrims and the fenders.

## MATERIALS

ITEM	SIZE	QUANTITY
3/4" (18 - 20mm) plywood	18" x 18" (46 x 46cm)	1 square
	15" (38.1cm) diameter circle	1/3 of circle
	23" (58.4cm) diameter circle	1/3 of circle
3-1/2" x 1" hardwood board (9cm x 2.5cm)	3" (7.6cm) length	1
3/8" (10mm) carriage bolts	2-1/2" (7cm) long	5
3/8" (10mm) wing nuts	---	3
3/8" (10mm) nuts	---	2
3/8" (10mm) flat washers	---	2

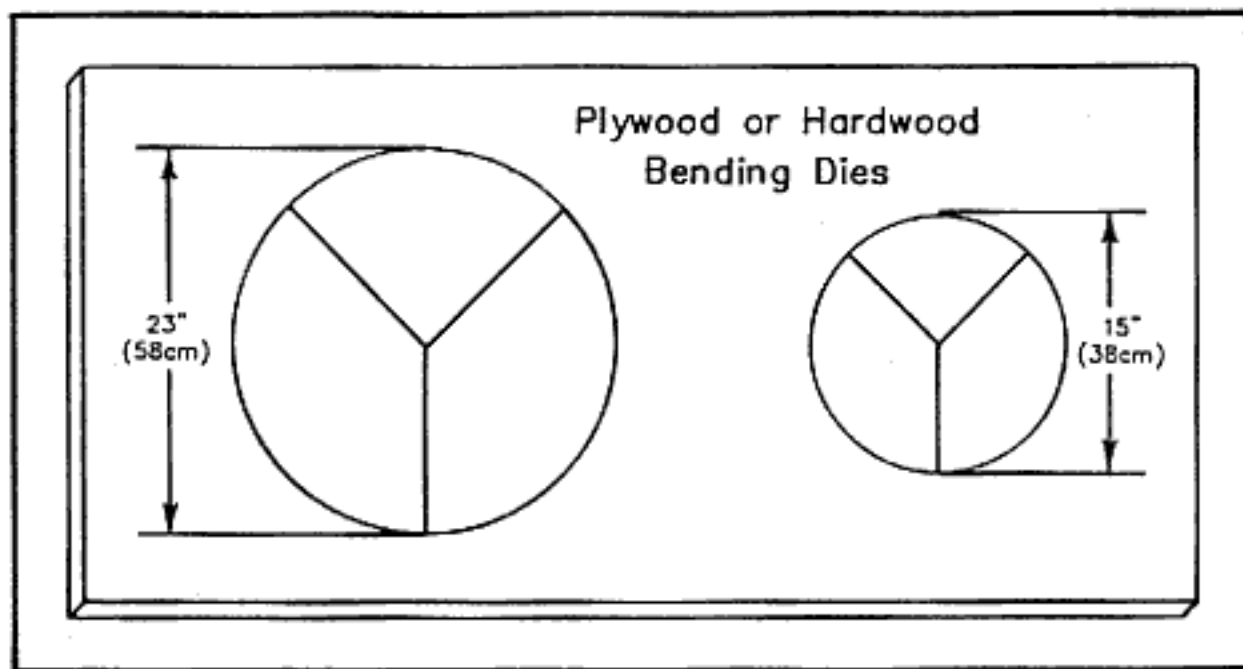

## DIRECTIONS

1) To make the bending dies, use a saber or coping saw to cut one 23" (58.4cm) diameter circle for fender bending and one 15" (38.1cm) diameter circle for handrim bending from a sheet of 3/4" (18 - 20mm) plywood (or longer lasting hardwood). If you are making chairs with 26" wheels, cut a 25" (63.5cm) circle instead of the 23" circle for fender bending. Cut each circle in thirds to make three dies.

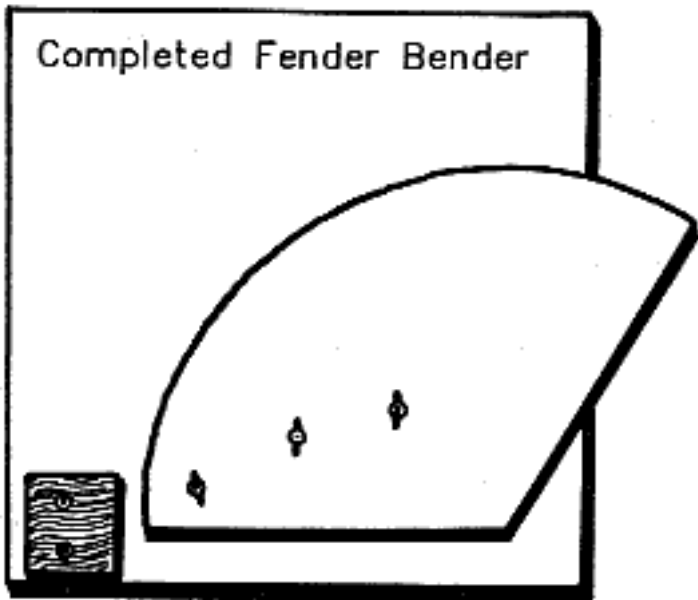

2) Cut a bending chock from a piece of hardwood. It should measure about 3" x 3" x 3/4" (7.6cm x 7.6cm x 2cm). Use carriage bolts to mount the bending chock on an 18 inch (46cm) square piece of 3/4 inch (18-20mm) plywood as shown in the diagram. The grain of the bending chock should run toward the bending die.

3) Bolt one fender bending die to the square of plywood as shown, leaving 3/4 of an inch (20mm) between the bending die and the chock. If the bending die is made of hardwood, point its grain toward the chock. Remove the fender bending die and mount the handrim bending die on the same three carriage bolts.

[Table of Contents](#)

# Center for International Rehabilitation

## Making Your Own Jigs

For those of you who are able to make your own jigs, this appendix includes a diagram and brief instructions for making each jig. Jigs can also be purchased ready made from Appropriate Technology International as part of the Basic Tool Kit.

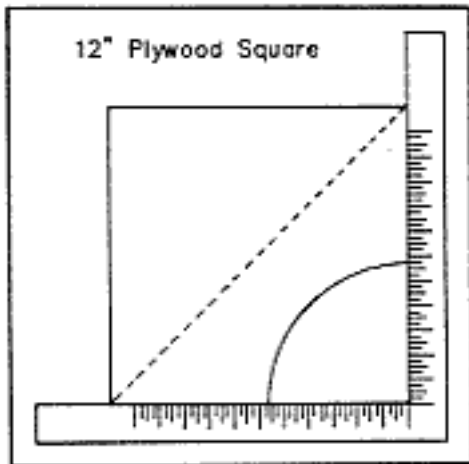

### PLYWOOD SQUARE

- 1) Cut a 12" (30cm) square piece of plywood. Check it with a carpenter's square to be sure that it is exactly square.
- 2) Cut the square in half along the diagonal.
- 3) Scribe an arc with a 4" (10cm) radius in the 90~corner of the triangle. Cut it out with a saber saw or coping saw.

### SEAT BACK DRILLING JIG

- 1) Cut a 16" (40.6cm) length out of 1-1/4" x 1-1/4" x 1/4" (30mm x 6mm) angle iron.
- 2) Mark, center punch, drill five holes, and insert 3/16" or 7/32" (5 or 5.5mm) I.D. bushings as shown in the diagram. The hole size will depend on the outside diameter of the bushings you are able to find. If you are unable to get drill bushings drill 7/32" (5.5mm) holes.

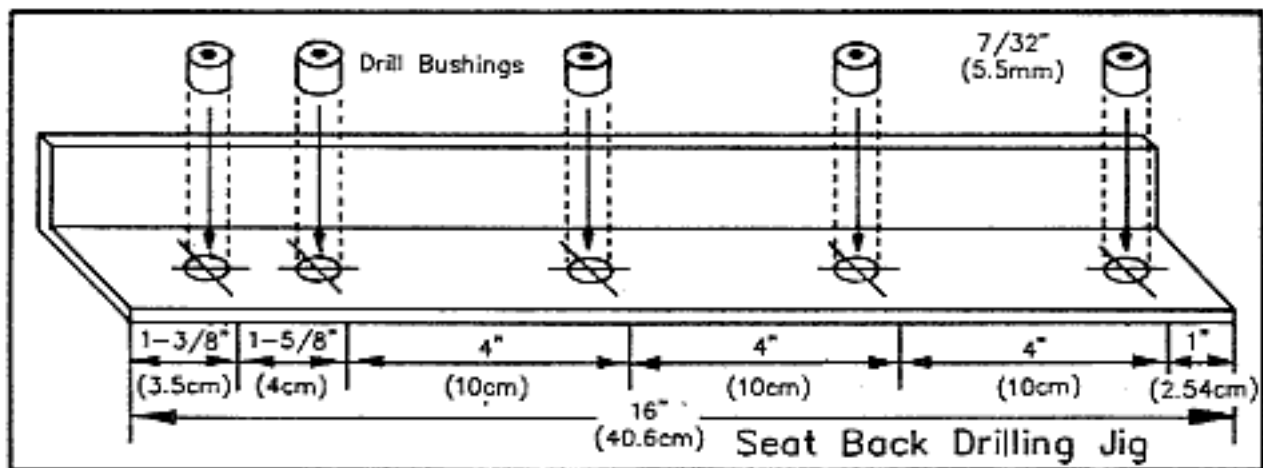

- 3) On the other side of the angle iron, measure 2-1/4" (5.7cm) from the top end and cut a 35~ angle "V" as shown. The cut should also leave a shallow groove on the inside of the side of the angle iron that has the holes in it.

4) Place the end closest to the cut in a vise, and bend the long end forming a 35~ angle as shown.

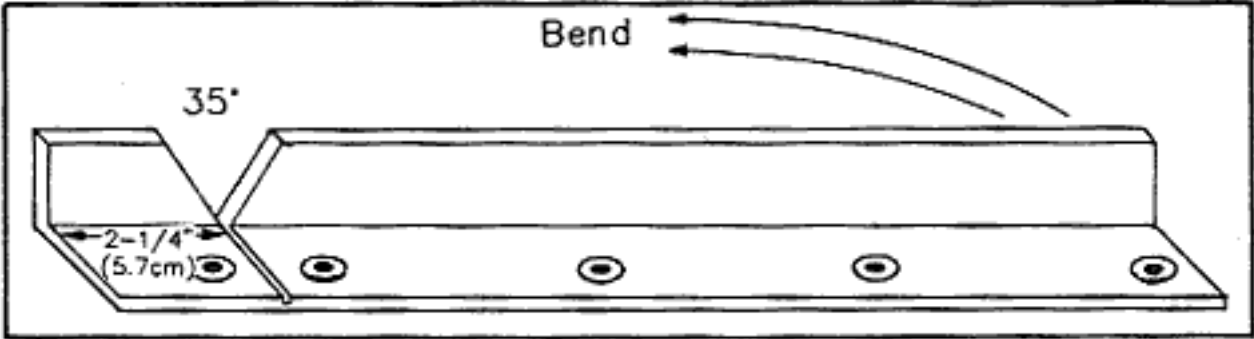

### BRAKE CATCH AND STOP WELDING JIG

### BRAKE MOUNTING HOLE DRILLING JIG

- 1) Mount 2-1/2" (60mm) "T" hinges on the edges of two blocks of plywood.
- 2) Make two 3/4" (18mm) cubes of solid steel. Cut a 1/8" wide groove in one cube and a deep "V" groove in the other. Drill a 5/16" (8mm) hole through the bottom of the "V" groove.
- 3) Weld the blocks of steel onto the ends of the hinges. The grooved sides should face down and run parallel to the backs of the hinges.
- 5) Place pieces of 7/8" O.D. tubing on the plywood. Bend the hinges until the block of steel is square to the plywood.

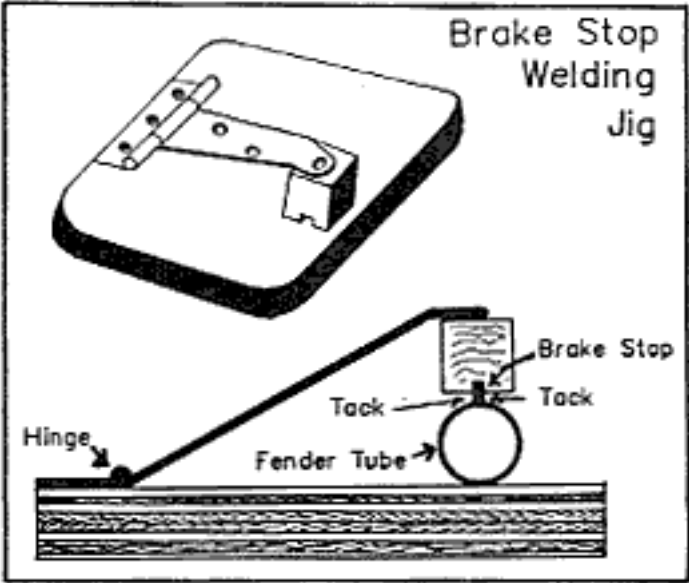
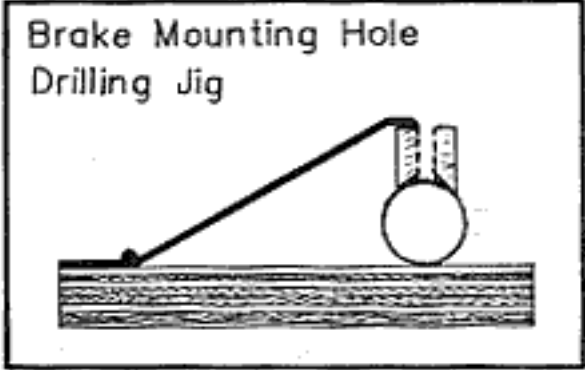

# SEAT SUPPORT TUBE DRILLING JIG AND SEAT EDGE BAR DRILLING INSERT

## MATERIALS

ITEM	LENGTH	QUANTITY
2" x 1/4" (50mm x 6mm) bar	18" (46cm)	1 piece
1-1/4" x 1-1/4" x 1/4" angle iron (30mm x 30mm x 6mm)	16" (40.6cm)	1 piece
1/4" (6mm) square bar	1-1/2" (38mm)	1 piece
7/32" (5.5mm) I.D. drill bushings	1/4" (6mm)	4
7/8" (22mm) square hardwood	17" (42cm)	1 piece

## DIRECTIONS

1) Set the angle iron on the bottom plate. Using the hardwood block to hold the angle iron up at a right angle, tack weld the angle iron to the bottom plate, remove the hardwood, check the angle and finish welding.

2) Place the 1/4" (6mm) square bar at one end of the angle iron. Check that it is at right angles to the angle iron and tack the end in place. Check the angle once more, tack the other end and weld.

3) Measure and mark the angle iron as shown. Drill holes into which the 7/32" (5.5mm) I.D. drill bushings will fit tightly.

Cut a 1/2" (12mm) wide trough on the side of the hardwood block. The trough should be 1/4" (6mm) deep, and it should be centered as shown in the diagram.

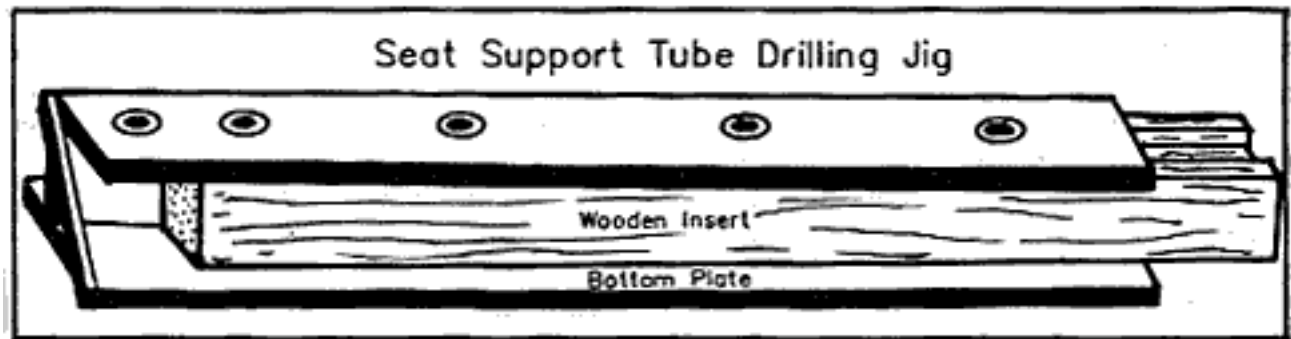



# X-BRACE WELDING JIG

## MATERIALS

ITEM	SIZE	QUANTITY
1" (25mm) square steel tubing	22-1/2" (57.2cm)	2 pieces
	16" (40.6cm)	1 piece
	10" (25.4cm)	3 pieces
	8" (20.3cm)	2 pieces
	7" (17.8cm)	2 pieces
	4" (10.2cm)	3 pieces
	2" (5.1cm)	2 pieces
	1/4" (6mm) thick steel plate	1-1/2" x 3" (4 x 8cm)
1/4" bolts with wing nuts	1" (2.5cm) long	2
1/4" (6mm) fender washers	1-1/2" (38mm)	2

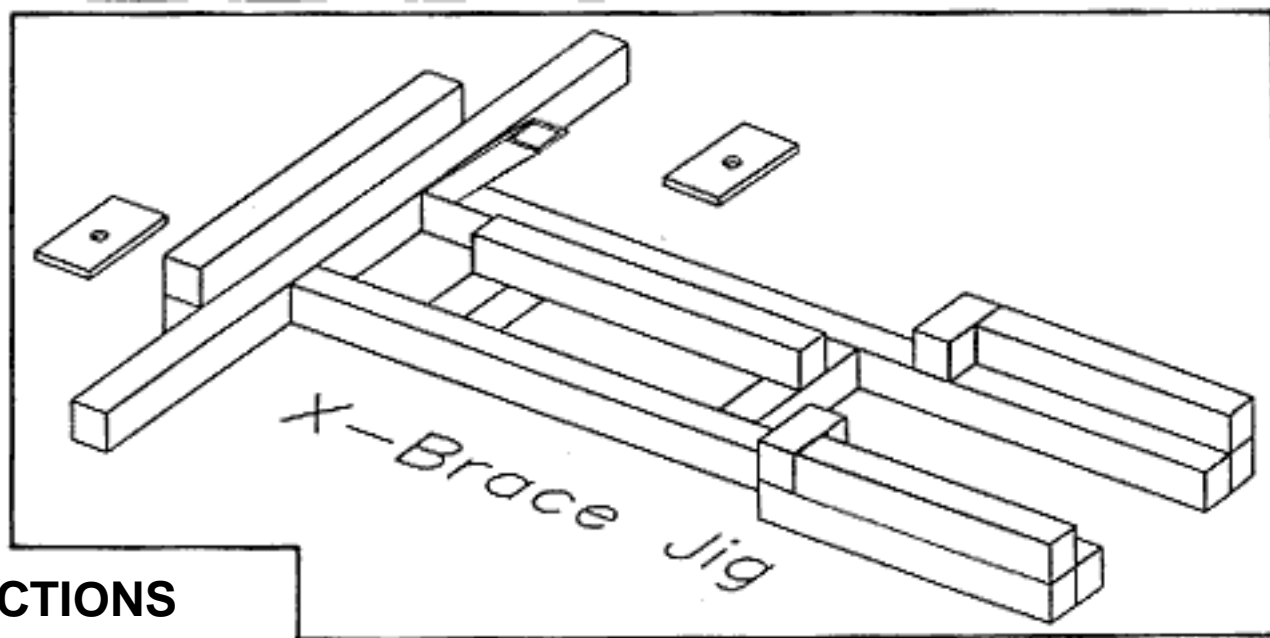

## DIRECTIONS

- 1) Clamp the 22-1/2 inch (57.2cm) pieces of tubing to a very flat table, separating them by four inches by putting the four inch long tubes between them, as in the diagram. Clamp the 16" (40.6cm) tube square to one end of the longer tubes, with the ends of the longer pieces centered on the 16" (40.6cm) tube.
- 2) Tack weld the 16" (40.6cm) tube to the ends of the 22-1/2" (57.2 cm) tubes. Gas welding with steel rod is cheaper and quicker than brazing with brass and there is no fear of cracking through fatigue, as would be the case for a wheelchair frame.

- 3) Check the alignment of the jig and bend the welds to straighten the jig, if it does not lie flat on the table. Complete the welds and realign the jig once more by bending it slightly if necessary.
- 4) Weld the rest of the pieces of tubing onto the jig as shown on the diagram. Make sure the tilted piece of tubing leans at 45~.
- 5) Weld the flat plates of steel on the ends of the 16" (40.6cm) tube. Set them at a 60~ angle to the plane of the jig.

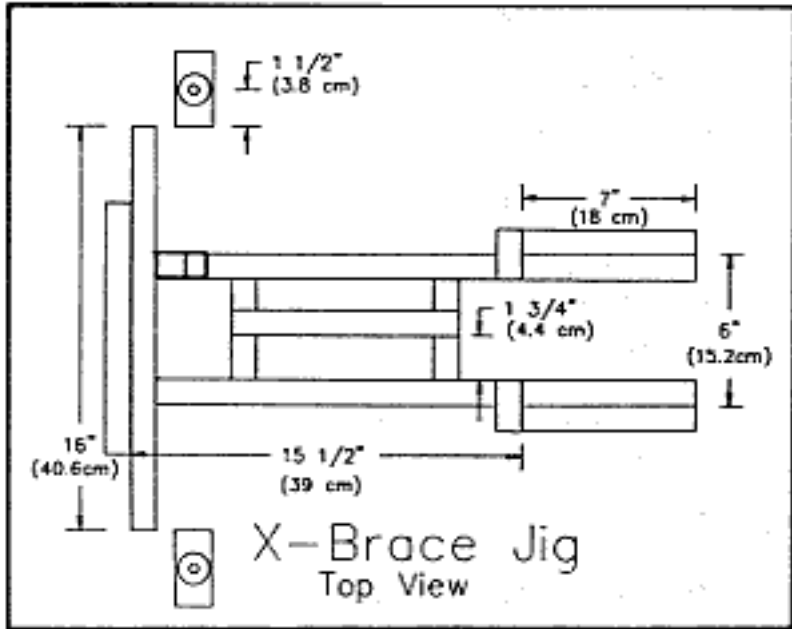

- 6) Insert an accurately made X-brace, if it is available, to test the accuracy of the jig. If the cross piece of the X-brace is longer than 16" (40.6cm), put short pieces of 1" (25mm) square tubing alongside the ends of the bottom pivot tube of the X-brace. The short pieces should serve as spacers so that the jig can be used for a crosspiece of any length ranging in whole inches or 25mm lengths from 16" (40.6mm) to 22" (55.9mm) (see chapter 9). Make all adjustments that are needed in the jig with great care; if the X-braces made in this jig are not well aligned, the resulting chairs will not open or fold well and will be unlikely to roll easily.

## X-BRACE CENTER HOLE DRILLING JIG

- 1) Cut a 16-1/2" (41.9cm) length of 1" x 1/4" (25mm x 6mm) bar. Mark the center of the bar and drill a 3/8" (10mm) hole.
- 2) If drill bushings are available, enlarge this hole to fit a 3/8" (10mm) I.D. bushing.
- 3) Grind off the ends of the bar at a 45~ angle. Be careful to keep the full 16-1/2" (41.9cm) length on the top edge.

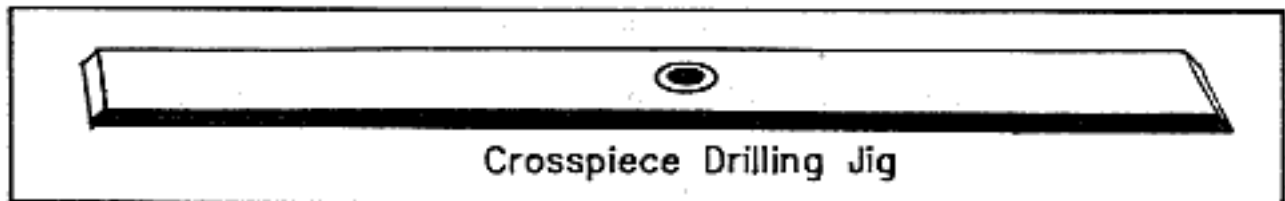

# SIDEFRADE BRAZING JIG

## MATERIALS

ITEM	SIZE	QUANTITY
1" (25mm) square tubing	19" (48.3cm) long	1 piece
	24-1/4" (61.6cm) long	1 piece
	24" (60.9cm) long	1 piece
	5" (12.7cm) long	2 pieces
7/8" O.D. tubing or equivalent	5" (12.7cm) long	2 pieces
5/8" (10mm) I.D. tubing	1" (2.54mm) long	2 pieces
1" x 1" x 1/8" angle iron (25mm x 25mm x 3mm)	5" (12.7cm) long	3 pieces
	8" (20cm) long	1 piece
3/4" (20mm) flat stock	2" (5.1cm) long	2 pieces
1/4" (6mm) bolts and wing nuts	3/4" (2cm) long	4
	2-1/2" (6.5cm) long	2
	7" (18cm) long	1
washers	5/16" I.D. x 1-1/2" O.D. (8mm I.D. x 38mm O.D.)	2
	2" (5cm) x 1/8" (3mm) flat stock	5" (12.7cm) long
3/4" (18mm) plywood	1" x 6" (2.54cm x 15.2cm)	2 pieces

## DIRECTIONS

- 1) Weld the lengths of 1" (25mm) square tubing together as shown.
- 2) Weld the 5/8" (16mm) I.D. axle socket holding tubes on as shown. There should be 1" (2.54cm) between the centers of the top and bottom axle socket tubes.
- 3) Drill holes in the longest piece of angle iron to mount the caster barrels. Cut and weld on the pieces of 1" (25mm) angle iron as shown.
- 4) Weld the flat bar to the rear of the longest piece of angle iron as shown.
- 5) Attach the flat bar jig extenders with 1/4" (6mm) O.D. x 3/4" (20mm) long bolts and nuts. These are used when making a wheelchair with a 26" wheel. They are removed when making a chair with a 24" wheel.

3) Drill holes in the longest piece of angle iron to mount the caster barrels. Cut and weld on the pieces of 1" (25mm) angle iron as shown.

4) Weld the flat bar to the rear of the longest piece of angle iron as shown.

5) Attach the flat bar jig extenders with 1/4" (6mm) O.D. x 3/4" (20mm) long bolts and nuts. These are used when making a wheelchair with a 26" wheel. They are removed when making a chair with a 24" wheel.

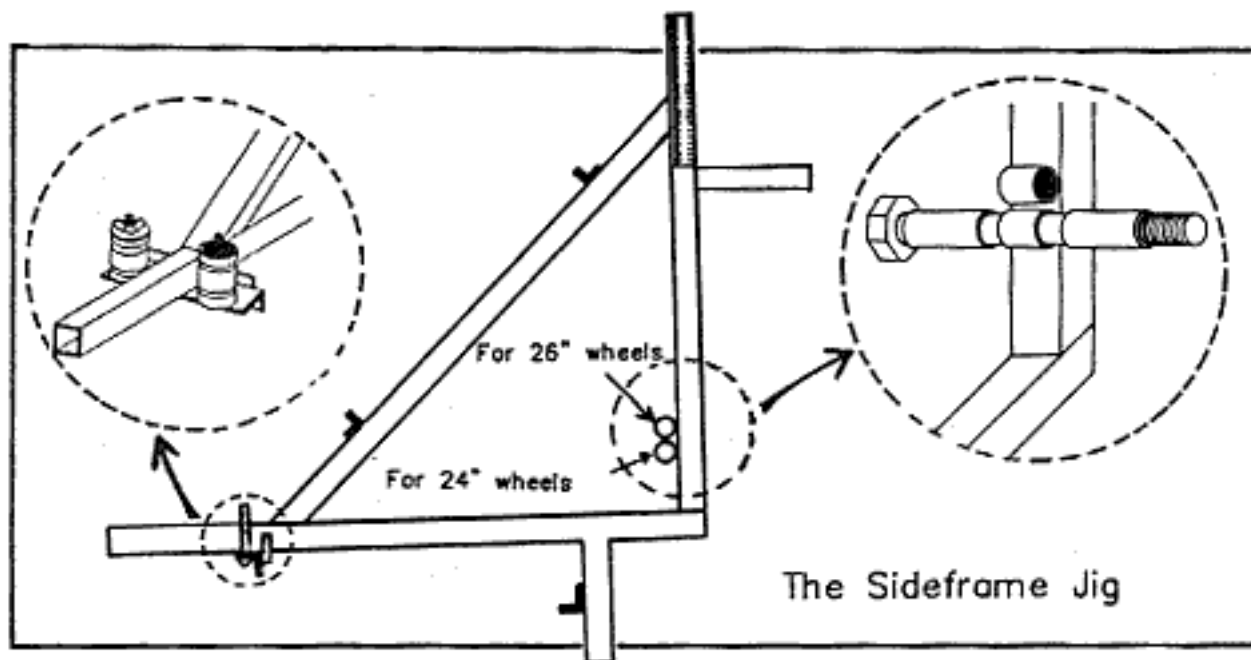

6) Make a wooden clamp from two plywood blocks connected by a 1/4" (6mm) threaded rod or bolt.

## HUB DRILLING JIG

This jig can be made for a hub with 40, 36, 32 or 28 spoke holes. Count the number of spoke holes in the wheelrims that you will be using before making your jig. The hub and the wheelrim must have the same number of spoke holes.

## MATERIALS

ITEM	SIZE	QUANTITY
1-3/4" O.D. steel tubing with 1/8" wall*	2-7/8" (7cm) long	1
1-1/2" O.D. tubing (or 1-1/4" conduit)	1-7/8" (4.6cm) long	1
1/8" (3mm) I.D. drill bushings	1/4" (6mm) or less	2

\* 1-3/4" O.D. solid rod or thickwall tubing is preferable if you can find a machinist to make your hub drilling jig on a lathe.

## DIRECTIONS

1) If a machinist is making this jig, ask her to make a piece with the following dimensions out of a single piece of solid rod or thickwall tubing, turned in a lathe.

2) If you are making the jig yourself, slip a 2" (5.1cm) length of 1-1/2" O.D. thinwall tubing inside a 3" (7.6cm) length of 1-3/4" O.D. tubing. The 1-3/4" O.D. tubing should have a wall thickness of 0.120". Tack the inner tubing in place to make a stop 1" (2.54cm) inside the jig.

3) The jig that will make a 40 hole hub must have 10 1/8" (3mm) diameter holes in each row. To make a 36 hole hub the jig will need 9 holes in each row; for 32 holes the jig will need 8 holes per row; for 28 holes the jig will need 7 holes per row. The first row of holes should be drilled 3/16" (4.8mm) from the stop (13/16" [20.6mm] from the end) and the second line 5/16" (7.9mm) from the stop (11/16" [17.5mm] from the end) as shown. Make two light lines around the tubing with a tubing cutter; one for each row of holes.

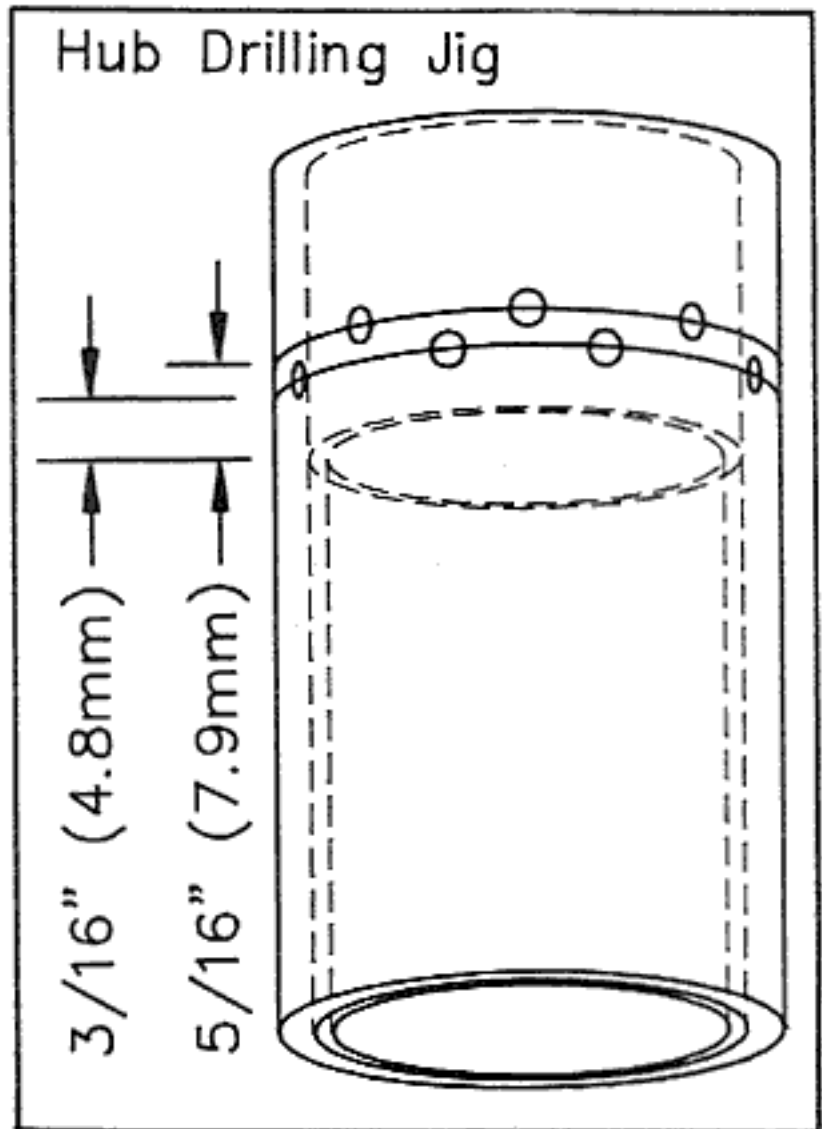

4) Drilling the holes so that they are evenly spaced around the hub is difficult. Color the end of the jig with a marking pen. This will help you see your scratches more easily. Set the vernier calipers at 0.550" (13.96mm) for a 40 hole jig; 0.611" (15.52mm) for a 36 hole jig; 0.687" (17.46mm) for a 32 hole jig; or 0.785" (19.95mm) for a 28 hole jig. Scratch a mark on the jig, measure around the jig with the calipers and scratch the next mark. Continue this process all the way around the jig. If the last mark does not match with the first, reset the calipers and try again until the distances between all of the marks are exactly equal.

5) Make the marks for the second row of holes exactly between each two marks in the first row.

6) Drill a 1/8" (3mm) hole centered on each of your marks.

7) After this type of jig has been used for awhile, the holes may become too large to locate the drill accurately. Dulling the side-cutters of the drill bit by spinning the drill between two pieces of sandpaper will help. Better yet is to put a 1/8" I.D. drill bushing into one hole on each row of holes. If your bushings are thicker than your tubing, let the bushings stick out on the outside of the tubing. Use these two bushings as guides for drilling all the holes in the hubs, as described in Chapter 11.

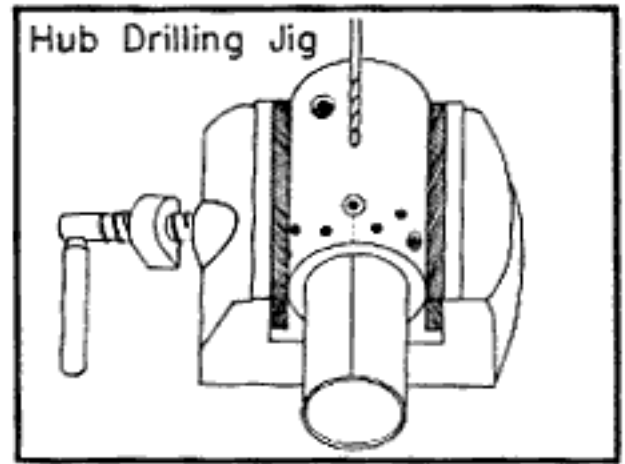

## SPOKING BOARD AND RIM DRILLING JIG

This jig can be made for either 24" or 26" wheels.

### MATERIALS

ITEM	SIZE	QUANTITY
3/4" (20mm) plywood	24" (61cm) x 24" (61cm)	1
	2-1/2" x 2" (6.4cm x 5.1cm)	3 or 4
1-1/4" x 1-1/4" x 1/4" angle iron (30mm x 30mm x 6mm)	1-3/4" (4.4cm) long	3 or 4
5/8" (16mm) O.D. threaded rod w/ nuts	4-3/8" (11cm) long rod	1 rod, 2 nuts
1/4" (6mm) bolts and nuts	2" (5.1cm) long	6 or 8
7/32" (5.5mm) I.D. drill bushings	---	3 or 4

## Directions

1) To make a jig for a 24" wheel, use a compass to draw a 21-3/4" (55.2cm) diameter circle on the 3/4" (18mm) thick plywood board. (The rim of most 24" wheels has an outside diameter of 21-3/4" (55.2cm); measure your rim and change the size of the circle, if necessary). For a 26" wheel, draw a 23-3/4" (60.3cm) circle on a 26" (66cm) piece of plywood.

2) Draw two lines through the middle of the circle that are at right angles to one another. Mark the points where the four lines intersect the circle.

3) Drill a 5/8" (16mm) hole in the center of the circle.

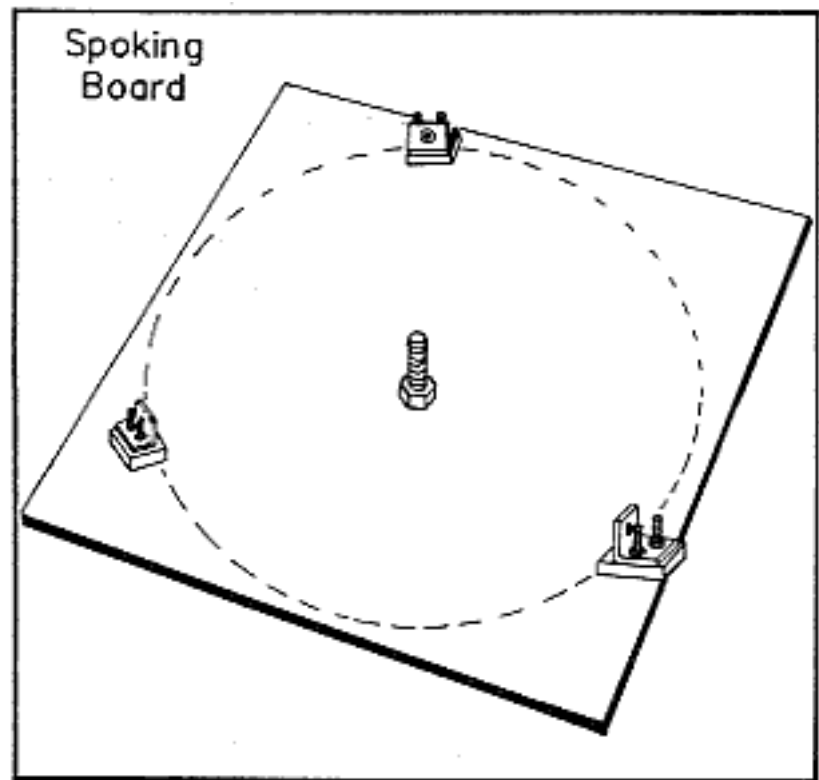

4) Scribe a line in the center of each piece of angle iron. Measure from the bottom of the angle iron up two thirds of the width of the wheelrim as shown. Mark this spot and drill a hole that will fit a drill bushing. If you can't get drill bushings, drill a 7/32" (5.5mm) hole.

5) Use a vise to insert the bushings.

6) Drill 1/4" (6mm) holes in the angle irons and the wooden blocks as shown. Position these blocks so that the scribed lines in the center of the angle irons line up with the positioning lines on the board, and so that the front of the drill bushings are positioned at the three points on the circle. Clamp them in place and drill through the plywood board. Bolt the angle irons in place using 2" bolts (1/4" [6mm] diameter).

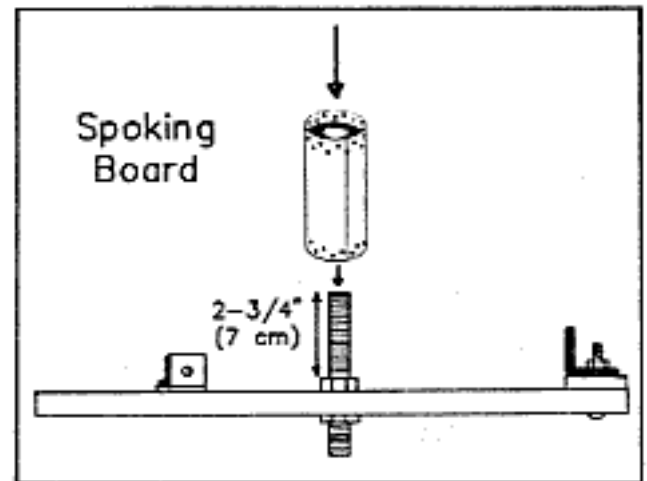

7) Using two nuts, mount a 5/8" diameter threaded rod (or 16mm, or 5/8" coarse thread reduced on a lathe to 15mm diameter) in the hole in the center of the plywood. Adjust the rod so that 2-1/4" (57mm) of the rod sticks up above one nut.

## CASTER FORK BENDING DIE

This die is made to be used with the Hossfeld type bender when bending the bar for the caster forks.

- 1) Cut a 1" (2.54cm) length of 2" waterpipe or other 2-3/8" (60mm) O.D. tubing.
- 2) Weld a 3/4" (19mm) I.D. washer inside the middle of the tubing.

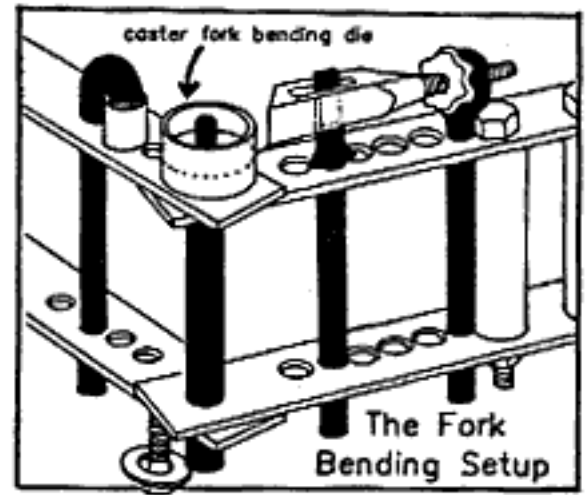

## CASTER FORK WELDING JIG

This jig holds the caster fork arms and pivot bolt in proper alignment for welding. If they are out of alignment, the chair will pull to one side. The following directions are for a jig which is easier to make than the jig that is part of the Basic Tool Kit. To make this jig, you will need to have one perfectly bent caster fork with the correct amount of caster fork trail (see Chapter 13).

## MATERIALS

ITEM	LENGTH	QUANTITY
perfectly bent caster fork	---	1
1/4" (6mm) x 3/4" (18mm) bar	13" (32cm) long	1
5/8" (15mm or 16mm) I.D. tubing	1-1/2" (3.6cm) long	1
5/16" (8mm) bolt	4" (10cm) long	1

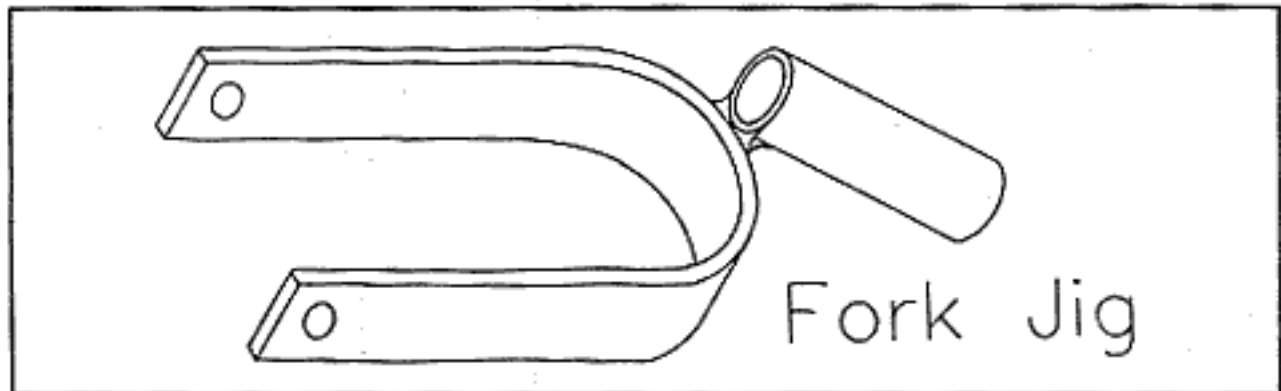



## DIRECTIONS

- 1) Set up the Hossfeld type bender to bend a caster fork using the 2-3/8" (60mm) O.D. caster fork bending die. Insert the 13" (33cm) length of 1/4" (6mm) x 3/4" (18mm or 20mm) bar.
- 2) Starting the bend 3-3/4" (9.5cm) from one end, bend the bar more than 180° until the two ends of the bar touch each other.
- 3) Remove the bar from the bender and pull the two arms of the caster fork open until they are parallel. Bending the bar too far and pulling it open will make a fork large enough to slip over the caster forks used in the wheelchair.
- 4) Using a 5/16" (8mm) bolt, mount the sample caster fork (one that has been bent correctly and that has 2-1/2" [6.3cm] of trail) inside the fork you just bent. Slip a piece of 5/8" (16mm) I.D. tubing over the caster fork bolt and lower it until it touches the outer fork as shown.
- 5) Braze the tubing onto the lower fork.

## PIVOTING TUBE BRAZING JIG

### MATERIALS

ITEM	QUANTITY
1/2" (12mm) x 1/8" (3mm) steel bar	6" (15.2cm)
7/8" O.D. tubing (or equivalent used for sideframe)	2-5/8" (6.7cm)

### DIRECTIONS

- 1) Bend the bar in a vise as shown.
- 2) Using a hacksaw, cut the piece of tubing in half up the center.
- 3) Weld the round bar to the half circle of tubing as shown.

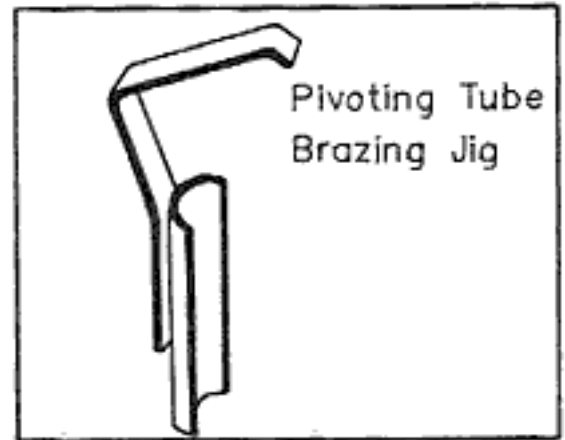

# LOWER FOOTREST TUBE DRILLING JIG

## MATERIALS

ITEM	LENGTH	QUANTITY
1/2" x 3/16" bar (12mm x 5mm)	5" (12.7cm)	1
1" x 1" x 1/4" angle iron (25mm x 25mm x 6mm)	3-5/8" (9.2cm)	1
5/16" x 1/2" x 1/4" drill bushings (8mm x 12mm x 6mm)	---	3

## DIRECTIONS

- 1) Measure, mark and drill holes for three drill bushings as shown.
- 2) Weld bar to angle iron as shown.

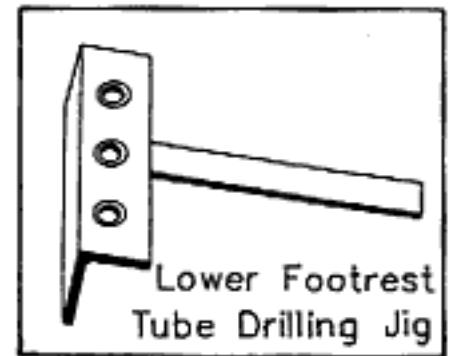
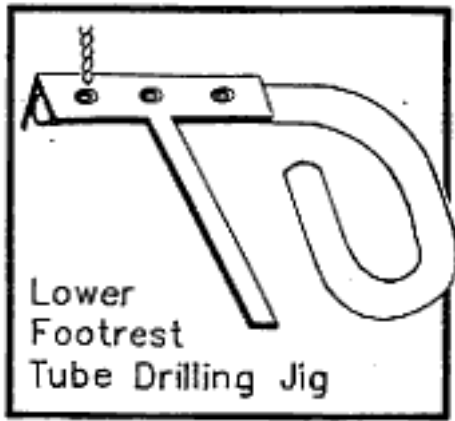

# STOP ROD WELDING JIG

## MATERIALS

ITEM	LENGTH	QUANTITY
7/8" O.D. (or equivalent) tubing	3" (7.6cm)	1 piece
1/2" (12mm) square tubing	1" (2.54cm)	1 piece
1/2" x 1/8" (12mm x 3mm) bar	3-1/2" (8.9cm)	1 piece

## DIRECTIONS

1) Clamp the the one inch (2.54cm) length of 1/2" (12mm) square tubing on top of the 3" (7.6cm) piece of 7/8" tubing, flush on one end as shown. Weld them together.

2) Center and square the 3-1/2" (8.9cm) length of 1/2" (12mm) x 1/8" (3mm) bar on top of the square tubing. Weld it in place.

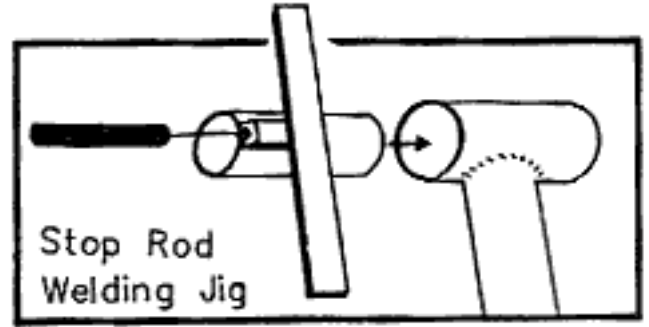

## UPPER FOOTREST DRILLING JIG

### MATERIALS

ITEM	LENGTH	QUANTITY
1" x 1" x 1/4" angle iron (25mm x 25mm x 6mm)	5-3/4" (14.6cm)	1
1/2" x 1/8" bar (12mm x 3mm)	1-1/2" (4cm)	1

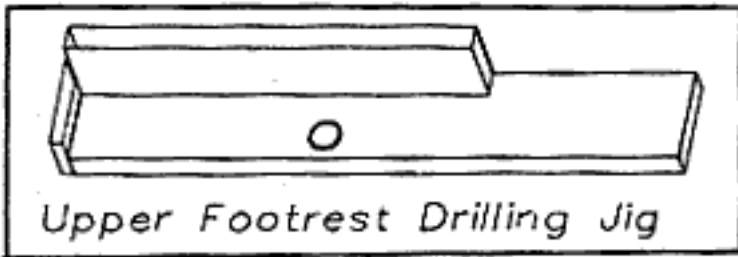

### DIRECTIONS

1) Weld on the stop bar and cut away 3" (7.6cm) of one arm of the angle iron.

2) Drill a 5/16" (8mm) hole 2.5" (6.4cm) from the stop bar.

## BRAKE COTTER PIN HOLE DRILLING JIG

### DIRECTIONS

1) Cut a 1-1/2" (4cm) length of 3/4" (18mm) square solid steel.

2) Center and drill a 5/16" (8mm) hole lengthwise through the steel, and a 1/8" (3mm) hole 1" (2.54cm) from one end.

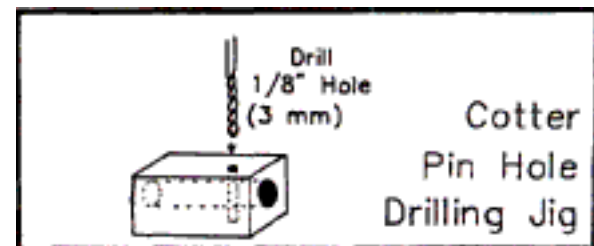

# MOLD FOR SOLID RUBBER TIRE

This mold is designed to form solid rubber tires under heat and pressure. The mold can be made on a lathe by a skilled machinist from 2 disks of steel or aluminum 12" (30cm) in diameter by 1" (2.54cm) thick.

To make a tire uncured rubber is packed into the large groove and the mold is clamped between two heated plates. Excess rubber flows into the two smaller grooves. The finished tire is stretched over a wooden or metal wheel (see chapter 12), bringing the tire to a full 8" (203mm).

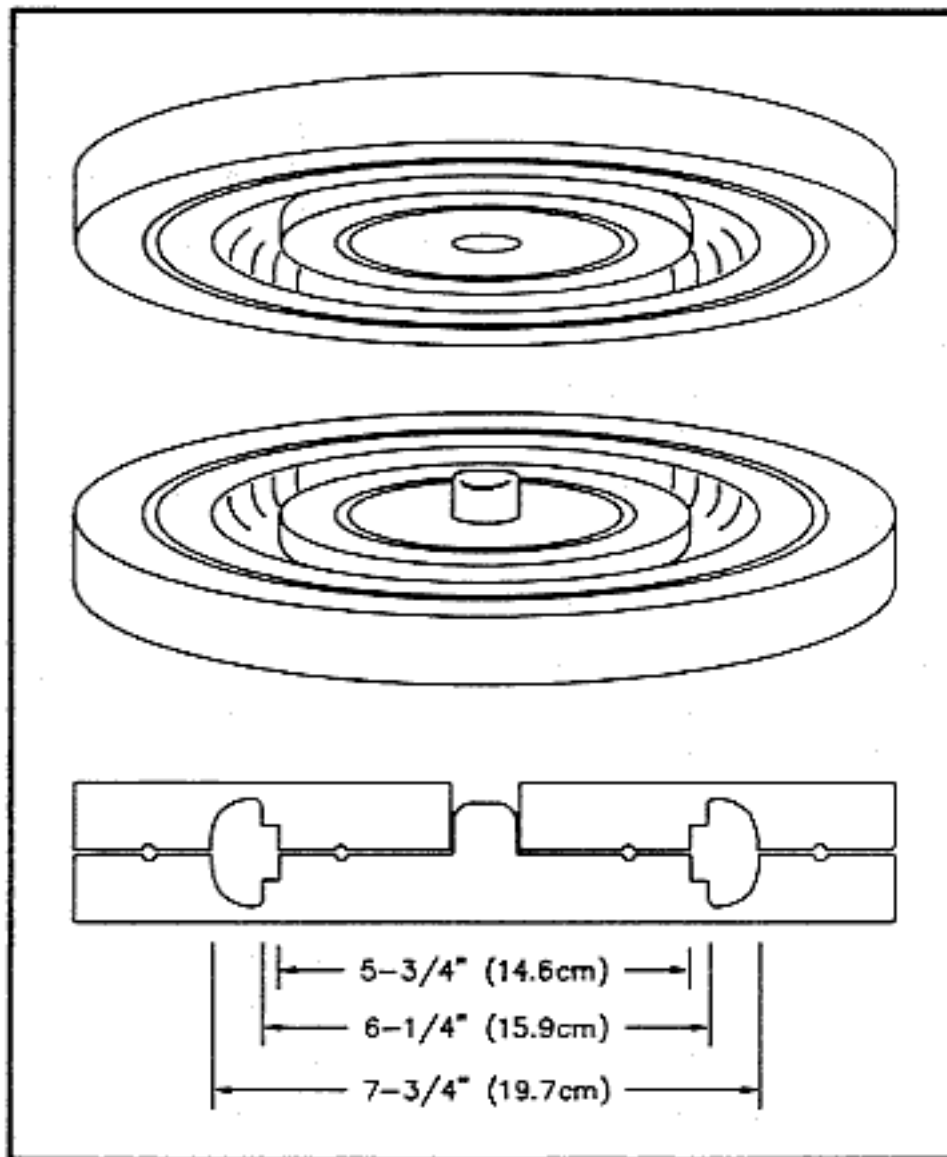

# Center for International Rehabilitation

## Appendix C Cushion Design

One of the most critical needs of a wheelchair rider is for a good cushion. Lack of a well designed and maintained cushion can quickly lead to serious pressure sores that are more disabling than the original disability. One of our promising wheelchair builders has lost his life to pressure sores, and several others have been too ill from sores to be able to build chairs well.

A good cushion is one that provides good support, evenly distributed over all of the rider's seat. When redness or sores indicate, a good cushion can be easily modified to give even less pressure on the bony parts of the rider's buttocks. A good cushion is well ventilated, so that sweat or spilled liquids do not keep the skin too damp, because dampness alone can cause the skin to break down. A good cushion is lightweight, is inexpensive - a few dollars at most - and lasts a long time with few repairs.

A cushion combining all these assets is unfortunately very difficult if not impossible to produce. We will offer two cushion designs with the following warning: No one cushion will work for everybody. Every cushion must be custom fit to the rider, and it cannot be safely used without careful and regular inspection of the rider for redness or, worse yet, for any signs of skin sores.

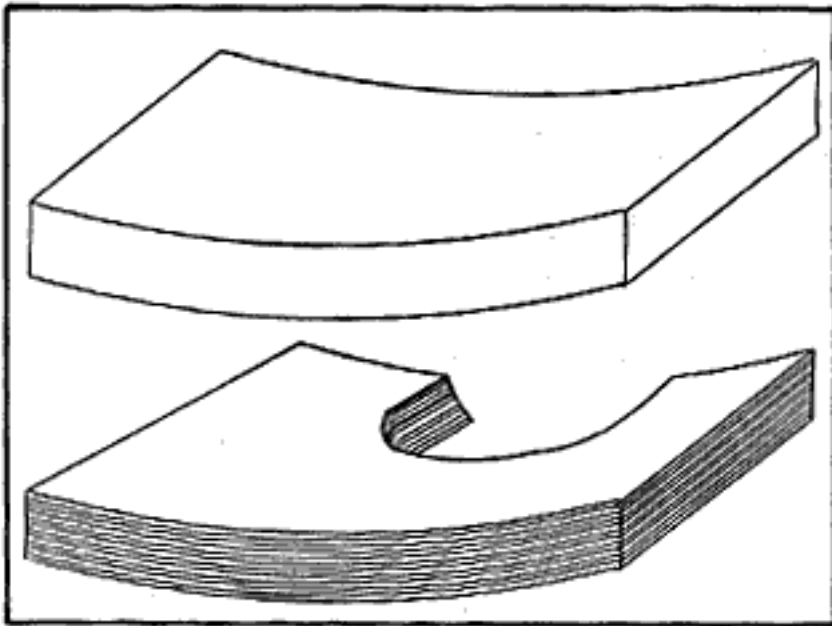

### THE CARDBOARD CUSHION

This cushion is the best all-purpose low cost cushion we have been able to develop so far. Ken Hawkins, David Werner, and Wally Motloch have made significant contributions to its design.

The base of this cushion is made of corrugated cardboard from ordinary shipping cartons. The cardboard is cut to provide pressure relief and molded to adapt it further to the individual user.

On top of this base is a softer cushion of about 2" (5cm) of high density foam or other cushion material. The cover is made of absorbent cotton, fit loosely.

# MATERIALS

ITEM	SIZE	QUANTITY
Corrugated cardboard	The same size as the user's seat upholstery	Enough layers for 2" (5cm) thick
High-density foam, 2" (5cm) thick	Same as above	Same as above
Soft cotton fabric	40 inches (1 meter) wide	One half yard (meter)

# DIRECTIONS

1) Cut out enough rectangles of corrugated cardboard to make a stack 2" (5cm) high. Bend each of these pieces with your hands so that they match the curve of a wheelchair seat.

2) Glue all the pieces of cardboard together with a water-resistant glue.

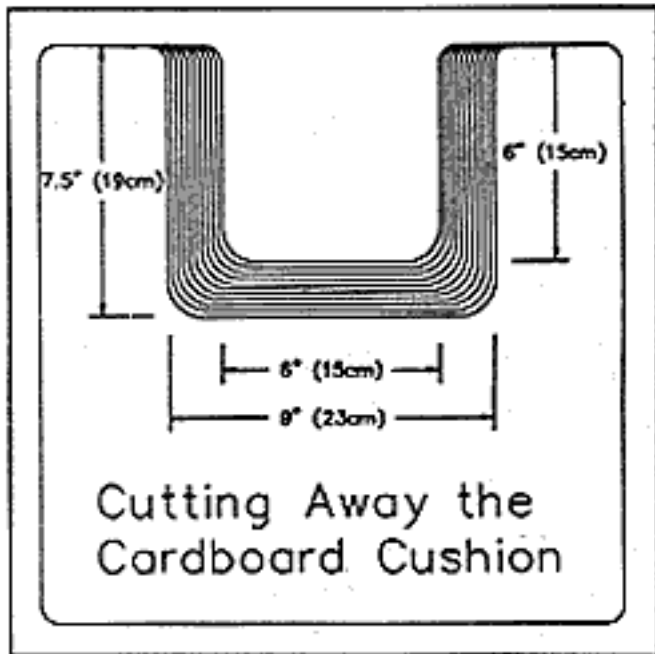

3) Cut out a pressure relief hole under the bony parts of the rider's seat as in the diagram. The dimensions given are approximate, and will have to be adjusted to the needs of the rider. The cardboard can be cut with a saber saw, a coping saw, or a keyhole saw.

4) Dampen the top of the cushion thoroughly until the water soaks through 2 or more layers of the cardboard.

5) Have the person who will be using the cushion sit on the dampened cardboard cushion base, without a cushion on top of the base, for several hours. The cardboard will change shape somewhat, molding itself to the shape of the rider's bottom. It is dangerous to sit on any surface without a good cushion. Inspect the rider regularly to be sure that there are no signs of skin breakdown.

6) Dry the cushion base and coat it thoroughly with waterproof varnish.

7) Make a cushion cover by sewing a loose envelope of absorbent cotton fabric. Do not make the cover tight - a tight cover can create extra pressure on the rider's bottom.

8) Use enough padding over the cardboard base to guarantee that there will be no areas of high pressure. If high density foam is not available, other cushioning materials might work: a much thicker low density foam, fiber furniture padding, or even a very soft folded blanket. In every case watch for red spots on the rider; there is no cushion design that will guarantee success in all cases.

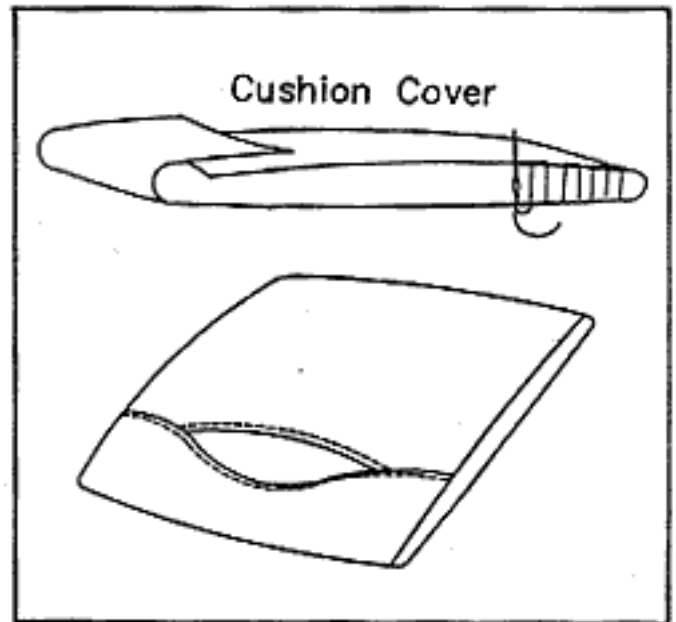

## THE INNERTUBE CUSHION

This cushion is a very low cost design that is well suited for sitting on hard surfaces, as in the bath. The cushion can also serve as a general purpose wheelchair cushion for some people. It was developed by the wheelchair rider-builders at Tahanan Walang Hagdanang (House With No Stairs), Quezon City, Philippines.

This cushion is made from a single bicycle innertube, 28 x 1.5 inch size, folded and tied in a pattern like the letter E. Because this cushion does not allow as much ventilation as some, a thick, soft terry cloth cover is recommended.

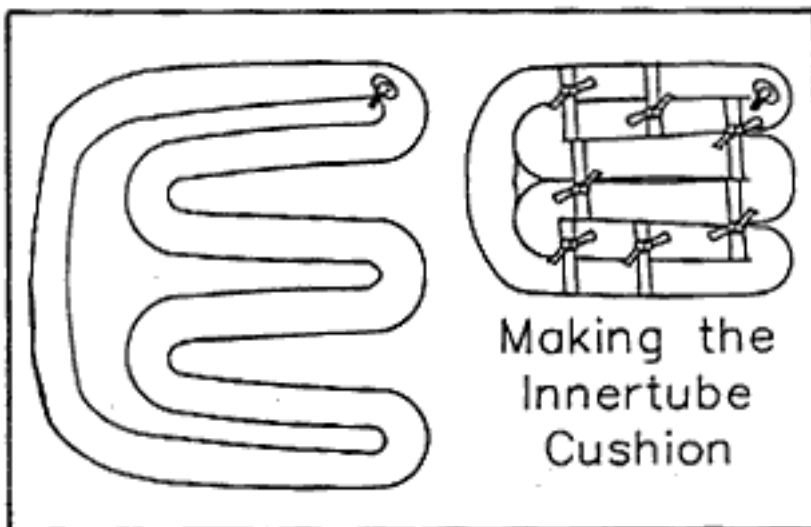

## DIRECTIONS

- 1) Fold the innertube in the pattern shown. Using strips of rubber cut from old innertubes, tie the folds of the innertube together. Place the valve in one corner, on the bottom side of the cushion. Make sure that all the knots in the rubber strips are also on the bottom of the cushion. You may need to use more ties than are shown.
- 2) Inflate the cushion slowly, adjusting the strips to keep the tubes well aligned. Be very careful to be sure the valve is not pressing on the user.